

**MODELS: 2154 - 2312** v03

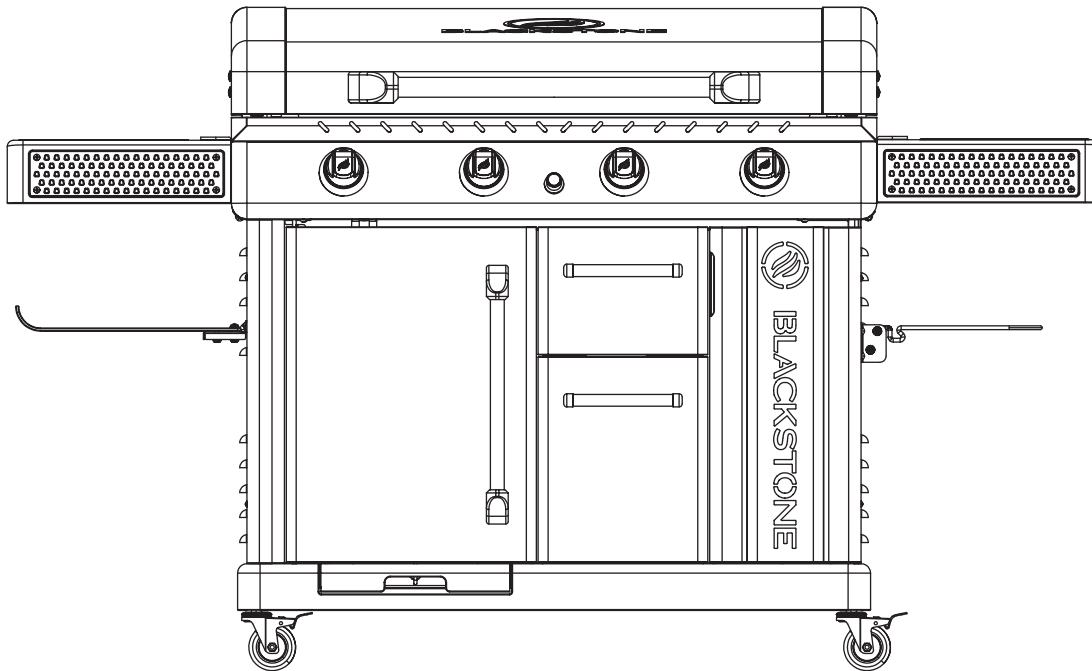

OWNER'S MANUAL

# 36" GRIDDLE WITH HOOD, CABINET & WIND GUARDS

## TABLE OF CONTENTS

IMPORTANT SAFETY INFORMATION .....	02
WARRANTY .....	03
ASSEMBLY GUIDE .....	04
USING YOUR BLACKSTONE .....	15
TROUBLESHOOTING .....	22



For the latest version of this manual,  
scan this code or visit  
[BlackstoneProducts.com/support](https://BlackstoneProducts.com/support)

### IMPORTANT:

This instruction manual contains important information necessary for the proper assembly and safe use of the appliance.

Read and follow all warnings and instructions before assembling and using the appliance.

Follow all warnings and instructions when using the appliance.

Keep this manual for future reference.

Installer/Assembler: Leave these instructions with the consumer.

### SAFETY ALERT KEY

#### ⚠ DANGER

Indicates a hazardous situation that, if not avoided, will result in death or serious injury.

#### ⚠ WARNING

Indicates a hazardous situation that, if not avoided, could result in death or serious injury.

#### ⚠ CAUTION

Indicates a hazardous situation that, if not avoided, could result in minor or moderate injury.

#### NOTICE

Indicates information considered important, but not hazard-related (e.g. messages related to property damage).

# IMPORTANT SAFETY INFORMATION

## ⚠ DANGER

If you smell gas:

- Shut off gas to the appliance.
- Extinguish any open flame.
- Open hood (if applicable).
- If odor continues, keep away from the appliance and immediately call your gas supplier or your fire department.

Failure to follow these instructions could result in fire or property damage, personal injury or death.

## ⚠ DANGER

- NEVER operate this appliance unattended.
- If a fire should occur, keep away from the appliance and immediately call your fire department. DO NOT attempt to extinguish an oil or a grease fire with water.

Failure to follow these instructions could result in fire or property damage, personal injury or death.

## ⚠ WARNING

- DO NOT store or use gasoline or other flammable liquids or vapors in the vicinity of this or any other appliance.
- An LPG cylinder not connected for use shall not be stored in the vicinity of this or any other appliance.

## GAS APPLIANCE SAFETY

- The use of alcohol, prescription, or non-prescription drugs may impair the consumer's ability to properly assemble or safely operate the appliance.
- Keep children and pets away from the appliance at all times.
- Have a type BC or ABC fire extinguisher readily available.

## DO NOT USE FOR PURPOSES OTHER THAN INTENDED.

- DO NOT use for commercial cooking.
- DO NOT use this appliance as a heater.

## ⚠ WARNING

Improper installation, use, adjustment, alteration, service, modification, or maintenance can cause injury or property damage. Refer to this manual.

## INSTALLATION MUST CONFORM WITH LOCAL CODES.

In the absence of local codes, installation must conform with either ANSI Z223.1/NFPA 54, CSA B149.1, or CSA B149.2.

## FOR OUTDOOR USE ONLY.



# WARRANTY

The North Atlantic Imports LLC 1-Year Warranty covers replacement parts up to one year after the date of purchase.

**TO ENABLE THIS WARRANTY, YOU WILL NEED TO PROVIDE:**

👉 Your appliance's Serial Number

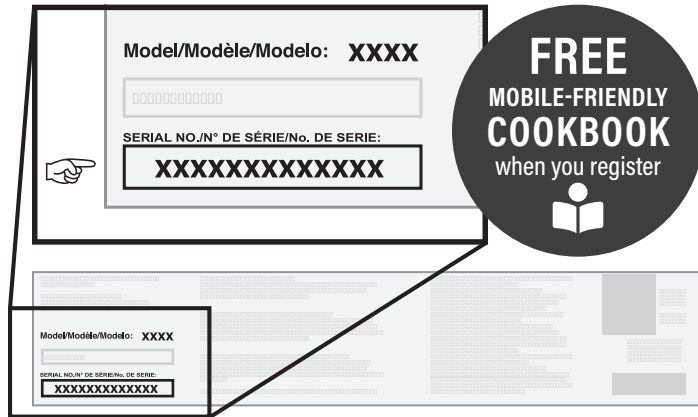

The Serial Number can be found on your appliance's Manufacturer Label.  
 (The Manufacturer Label is a large silver sticker found on the body of your appliance.)



Register your appliance at  
[BlackstoneProducts.com/register](https://BlackstoneProducts.com/register)

**WARRANTY OVERVIEW**

North Atlantic Imports, the manufacturer, will warranty for one year from purchase all parts, workmanship, and finishes. It will be the manufacturer's option as to whether to repair or replace any of the above items. All warranties are limited to the original purchaser only. This warranty does not cover any liability on the part of North Atlantic Imports, its agents or employees, for any indirect or consequential damages for breach of warranty. The purchaser must follow the manufacturer's usage instructions.

Under no circumstances is the manufacturer responsible for damages from the failure to operate the cooking station properly. It is the responsibility of the purchaser to establish the warranty period by verifying the original purchase date with original sales receipt.



**DETAILED EXPLANATION OF THE WARRANTY**

North Atlantic Imports LLC warrants to the owner that the product covered by this agreement is free from defects in material and workmanship under normal use and service for which it was intended if, but only if, it has been operated in accordance with North Atlantic Imports LLC instructions exclusively for domestic use, and not for private or public club, institutional or commercial purposes.

North Atlantic Imports LLC's obligation under this warranty is limited to replacing or repairing, free of charge, any part or parts that may prove, to the satisfaction of North Atlantic Imports LLC, to be defective under normal home use and service within the following stated periods of time from the date of purchase; for one year from purchase, all parts, finish, and workmanship. Should any failure to conform to this warranty become apparent during applicable warranty periods stated above, the original purchaser must notify North Atlantic Imports LLC of breach of warranty within the applicable warranty period.

North Atlantic Imports LLC shall upon notice and compliance by the original purchaser with such instructions, correct such nonconformity by repair or replacement of the defective part or parts.

Correction in the manner provided above shall constitute a fulfillment of all obligations of North Atlantic Imports LLC with respect to the quality of the product.

North Atlantic Imports LLC does not warrant this equipment to meet the requirement of any safety code of any state, municipality or other jurisdiction, and the original purchaser assumes all risk and liability whatsoever resulting from the use thereof, whether used in accordance with North Atlantic Imports LLC instructions or otherwise.

This warranty does not cover and is intended to exclude any liability on the part of North Atlantic its agents, servants or employees whether under this warranty or implied by law for any indirect or consequential damages for breach on any warranty. The purchaser must establish all applicable warranty periods pursuant to this warranty by verifying the original purchase date by producing the dated sales receipt. This warranty shall not apply to this product or any other part thereof which has been subject to accident, negligence, alteration, abuse, or misuse or which has been repaired or altered without North Atlantic written consent, outside of North Atlantic Imports LLC factory. The full manufacturer warranty is not valid for griddles purchased from unlicensed, third-party resellers, purchased at a discount due to missing or damaged parts, or purchased as a floor model; at the discretion of North Atlantic Imports.

North Atlantic Imports LLC makes no warranty whatsoever in respect to accessories or parts not supplied with it. This warranty shall apply only within the boundaries of the United States of America and Canada. This warranty gives the original purchaser specific rights, and the original purchaser may also have other rights, which vary from state to state.

# ASSEMBLY GUIDE

## EXPLODED VIEW

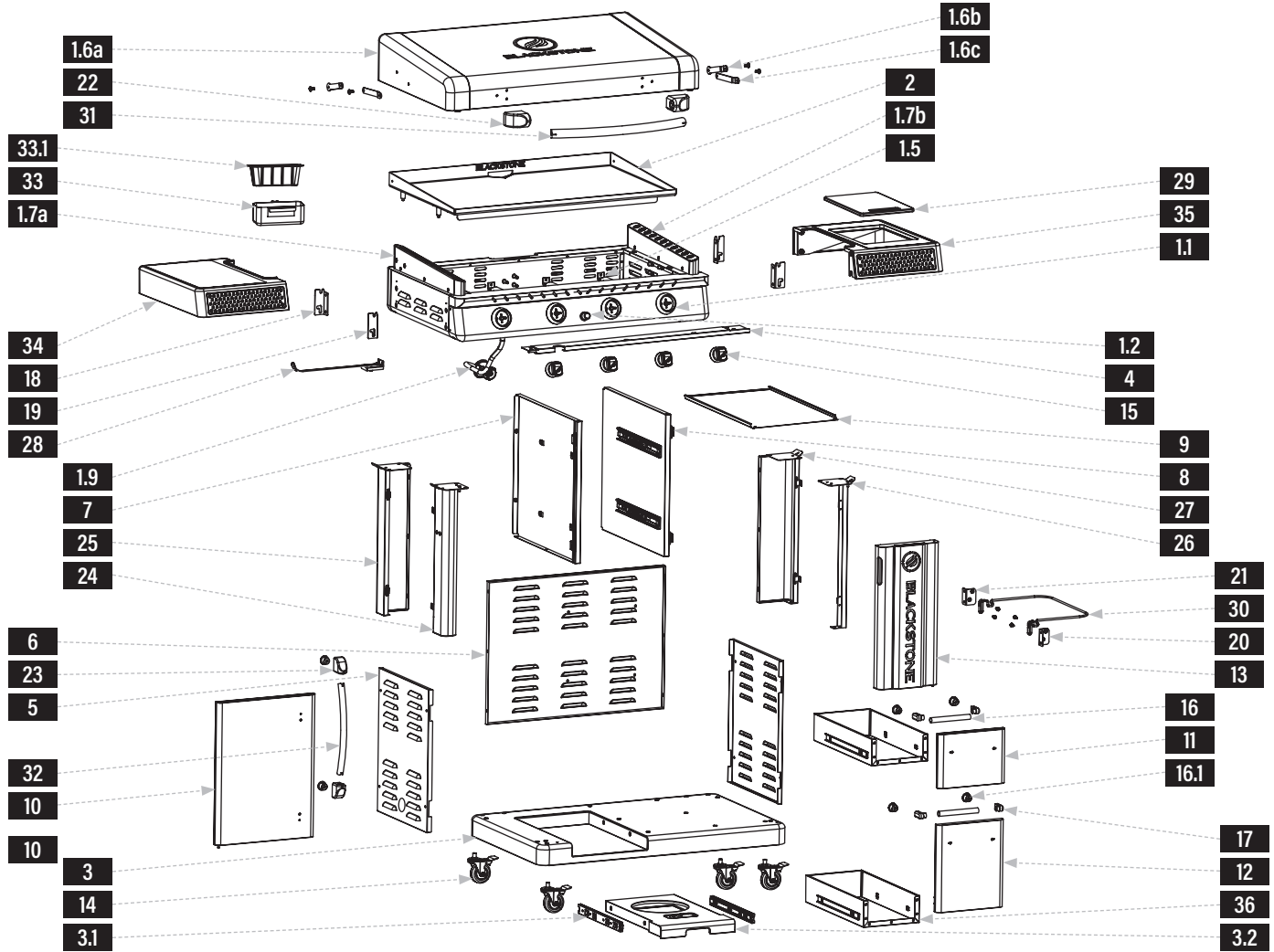





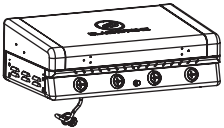
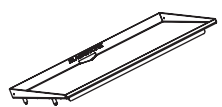
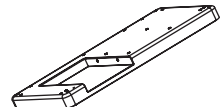
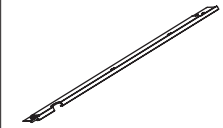
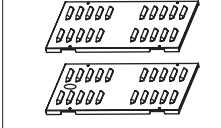
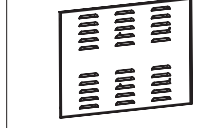



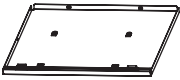

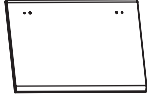

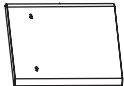



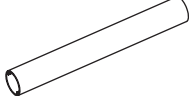
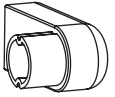
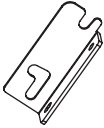
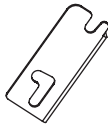
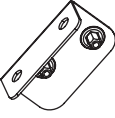
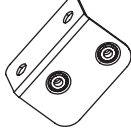
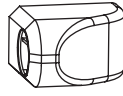

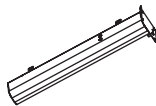
## PARTS LIST

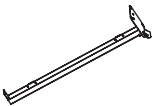
PARTS	QTY	PARTS	QTY	PARTS	QTY	PARTS	QTY
1.1 Control knob bezels	4	1.5 Tubular burners	4	1.7b Right baffle panel	1	16.1 Door & drawer handle inserts	6
1.2 Electric Igniter	1	1.6a Hood	1	1.8 Gas tank heat shield	1	33.1 Grease cup liner	1
1.3 Electric igniter wire (4 pcs per 1 set) with electrode	1	1.6b Hood hinge lever 1	2	1.9 Regulator hose	1	36.1 Left drawer slides	2
1.4 Gas rail & Valves	1	1.6c Hood hinge lever 2	2	3.1 Gas tank slides	2	36.2 Right drawer slides	2
		1.7a Left baffle panel	1	3.2 Sliding tray assembly	1		

<b>1</b> Griddle body (1 piece) 	<b>2</b> Griddle top (1 piece) 	<b>3</b> Cart base (1 piece) 	<b>4</b> Top bracket (1 piece) 	<b>5</b> Side panels (2 pieces) 	<b>6</b> Back panel (1 piece) 
--	--	--	---	---	---

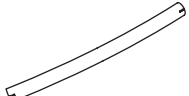
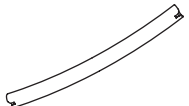
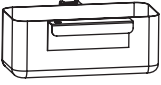

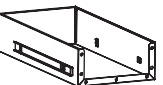
<p><b>7</b> Left drawer panel assembly (1 piece)</p> 	<p><b>8</b> Right drawer panel assembly (1 piece)</p> 	<p><b>9</b> Drawer heat shield (1 piece)</p> 	<p><b>10</b> Left door (1 piece)</p> 	<p><b>11</b> Upper drawer front panel (1 piece)</p> 	<p><b>12</b> Lower drawer front panel (1 piece)</p> 
<p><b>13</b> Right door (1 piece)</p> 	<p><b>№ 1 BOX</b> INSIDE № 4 BOX</p>	<p><b>14</b> Caster wheels (4 pieces)</p> 	<p><b>15</b> Control knobs (4 pieces)</p> 	<p><b>16</b> Drawer handles (2 pieces)</p> 	<p><b>17</b> Drawer handle standoffs (4 pieces)</p> 
<p><b>18</b> Side shelf bracket (A) (2 pieces)</p> 	<p><b>19</b> Side shelf bracket (B) (2 pieces)</p> 	<p><b>20</b> Garbage bag bracket (A) (1 piece)</p> 	<p><b>21</b> Garbage bag bracket (B) (1 piece)</p> 	<p><b>22</b> Hood handle standoffs (2 pieces)</p> 	<p><b>23</b> Door handle standoffs (2 pieces)</p> 
<p><b>№ 2 BOX</b> INSIDE № 4 BOX</p>	<p><b>24</b> Front-left leg assembly (1 piece)</p> 	<p><b>25</b> Rear-left leg assembly (1 piece)</p> 	<p><b>26</b> Front-right leg assembly (1 piece)</p> 	<p><b>27</b> Rear-right leg assembly (1 piece)</p> 	<p><b>28</b> Paper towel holder (1 piece)</p> 
<p><b>№ 3 BOX</b> INSIDE № 4 BOX</p>	<p><b>№ 4 BOX</b></p>	<p><b>29</b> Cutting board (1 piece)</p> 	<p><b>30</b> Garbage bag holder (1 piece)</p> 	<p><b>31</b> Hood handle (1 piece)</p> 	<p><b>32</b> Door handle (1 piece)</p> 
<p><b>33</b> Grease cup (1 piece)</p> 	<p><b>34</b> Left side shelf (1 piece)</p> 	<p><b>35</b> Right side shelf (1 piece)</p> 	<p><b>36</b> Drawer assemblies (2 pieces)</p> 		

**INSIDE № 1 BOX**

- 37** Hardware pack (1 piece)
- a.** M6x15 screws (49 pieces)
- b.** M5x10 screws (38 pieces)
- c.** Spares
- d.** M5 step bolts (4 pieces)
- e.** Small M6 step bolts (8 pieces)
- f.** Large M6 Step bolts (6 pieces)

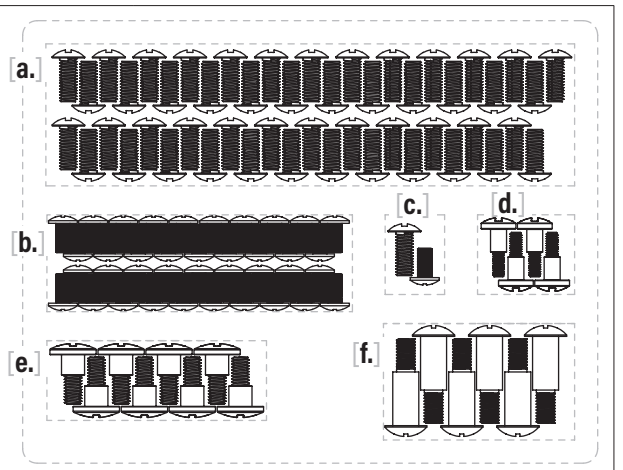

## ASSEMBLY INSTRUCTIONS

Find a large, clean area to assemble your appliance.

Remove all packing material before assembling.

### ⚠ CAUTION

Sharp edges. Wear gloves while assembling.

### ⚠ CAUTION

Heavy pieces. Two people should assemble this appliance.

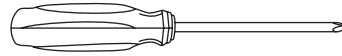
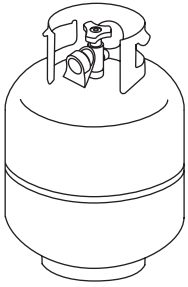

#### NOT INCLUDED:

LPG cylinder

Size: 18 x 12 in (45 x 30 cm), 20 lb (9 kg)

LPG cylinder must include collar to protect LPG cylinder valve.

#### NOT INCLUDED:

AA battery

#### TOOL NEEDED:

#3 Phillips head screwdriver

**STEP 01** Place the cart base upside down and screw on the four (4) lockable caster wheels.

(Ensure that the caster wheels are locked before attaching them.)

**STEP 02** Set the cart base on its wheels, and use three (3) M6x15 screws [a.] to attach the left-rear leg to the cart base.

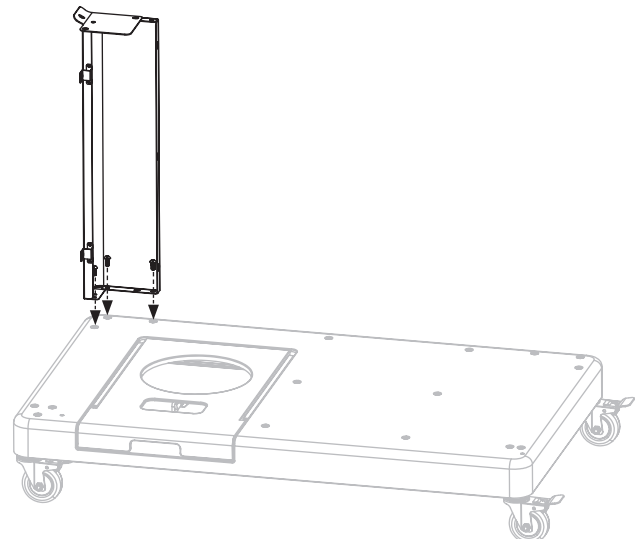
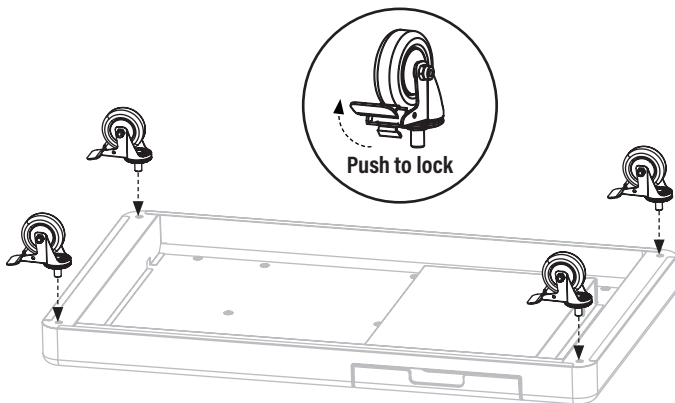



**STEP 03** Use three (3) M6x15 screws [a.] to attach the front-left leg to the cart base.

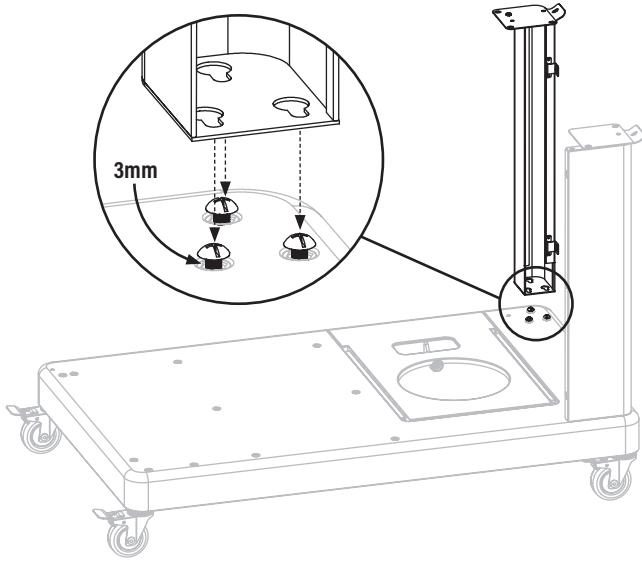

**STEP 04** Use three (3) M6x15 screws [a.] to attach the rear-right leg to the cart base.

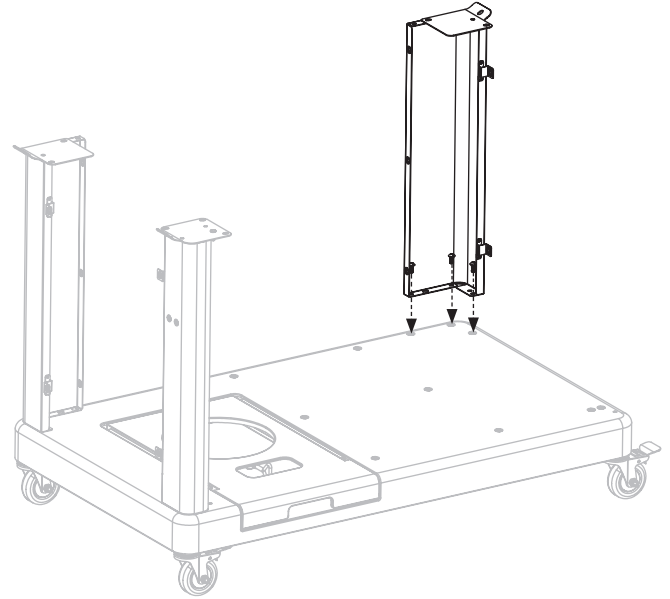

**STEP 05** Use two (2) M6x15 screws [a.] to attach the front-right leg to the cart base.

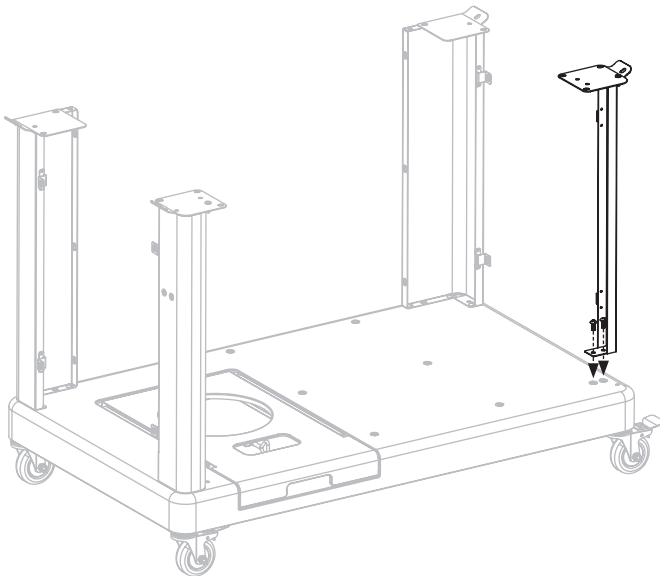

**STEP 06** Use six (6) M5x10 screws [b.] to attach the back panel to the rear-left leg and rear-right leg.

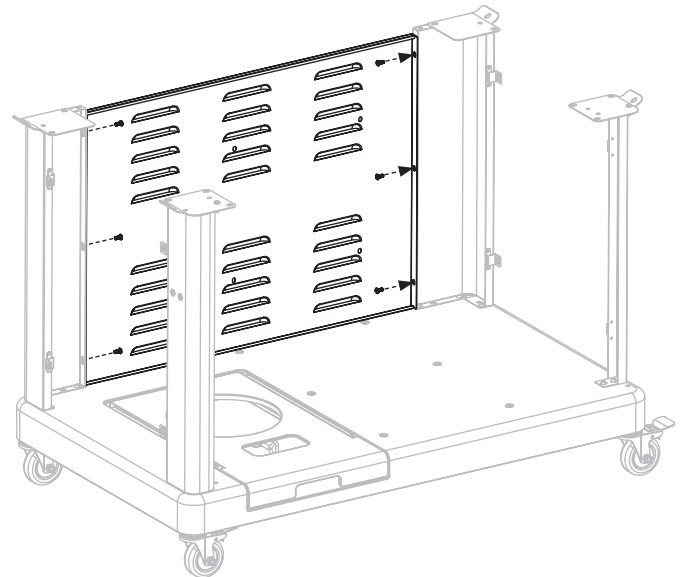

**STEP 07** Use four (4) M5x10 screws [b.] to attach the left drawer panel and right drawer panel to the back panel.

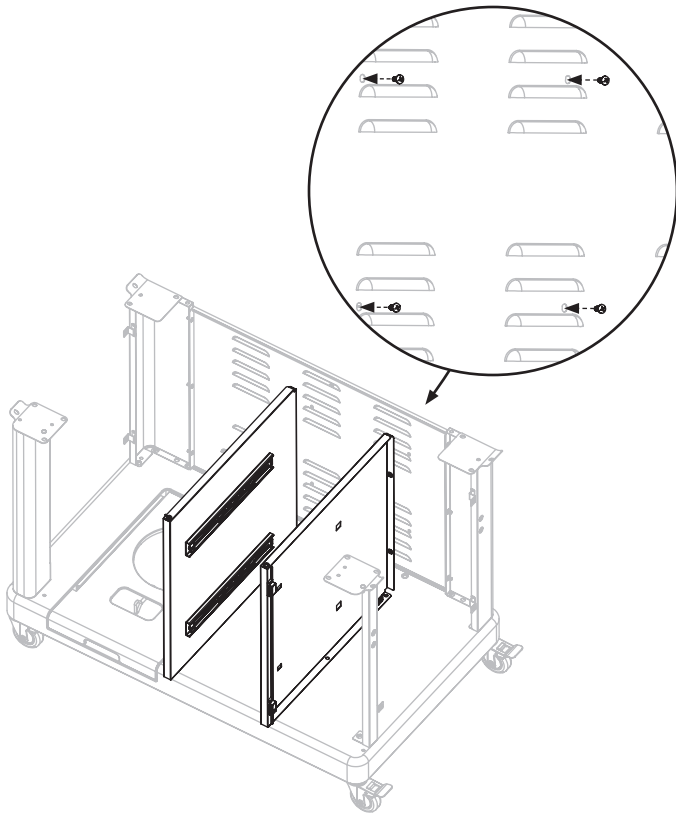

**STEP 08** Use three (3) M6x15 screws [a.] to attach the left drawer panel to the cart base.

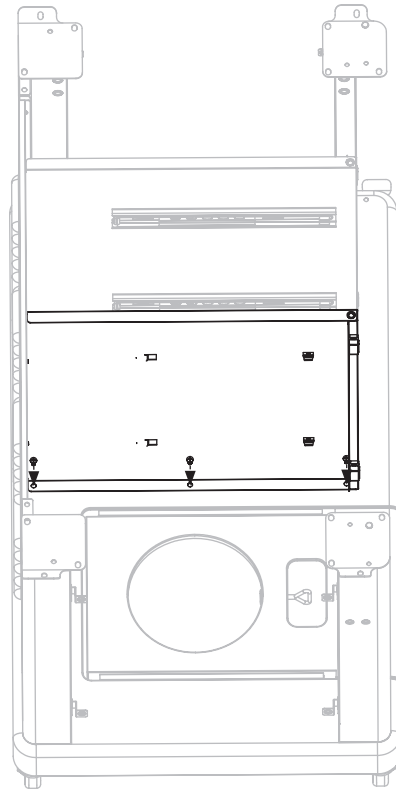

**STEP 09** Use three (3) M6x15 screws [a.] to attach the right drawer panel to the cart base.

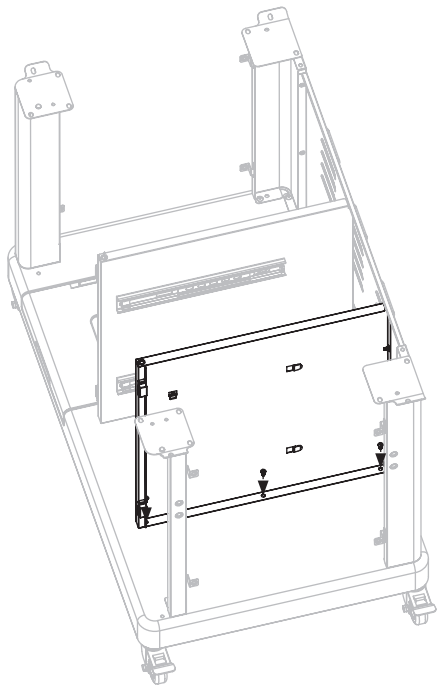

**STEP 10** Align the holes on the drawer heat shield with the holes on the left and right drawer panels.

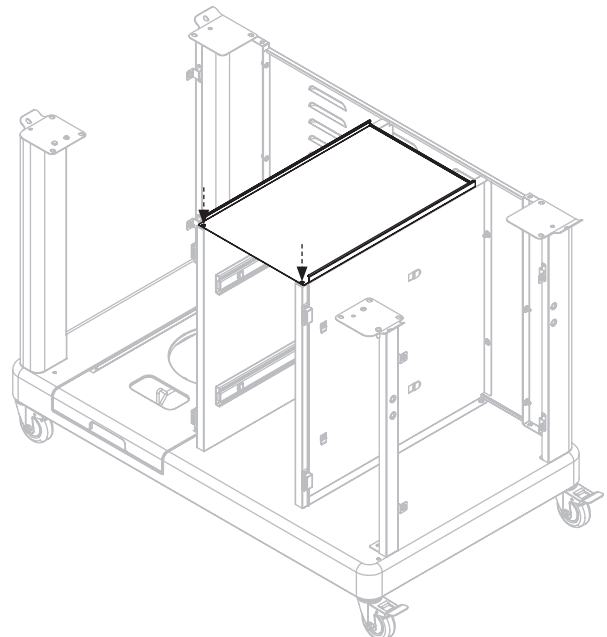





**STEP 11** Use four (4) M5x10 screws [b.] to attach the top bracket to the front-left and front-right legs, and secure the drawer heat shield to the left and right drawer panels.

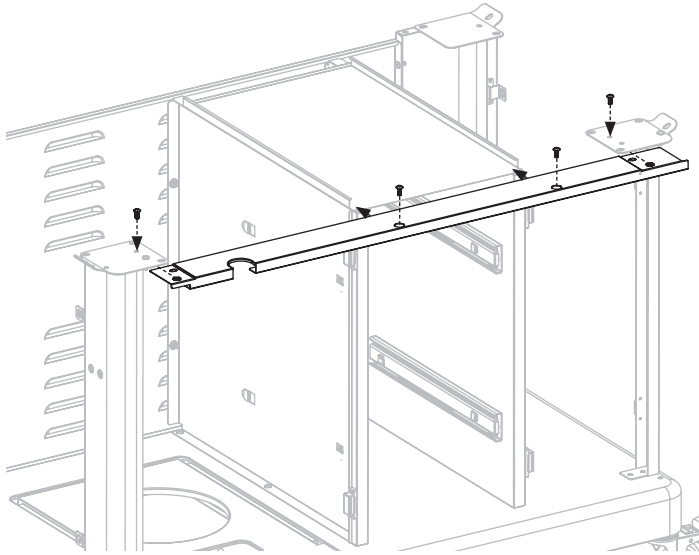

**STEP 12** With the help of another person, set the griddle body on its back and use fourteen (14) M6x15 screws [a.] to attach the griddle cart to the griddle body.

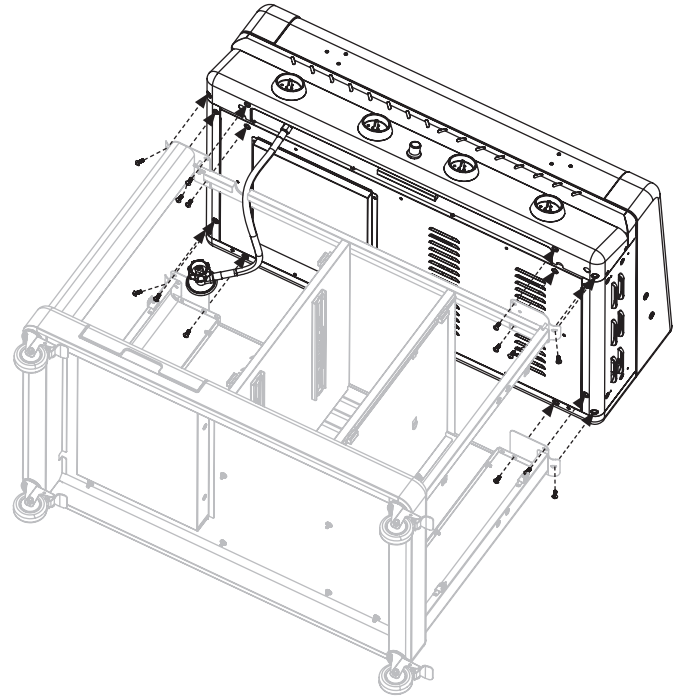

**STEP 13** With the help of another person, set the griddle on its feet. Use four (4) M5x10 screws [b.] to attach the side panel with the black plug to the rear-left leg and the front-left leg. (Note: the plug is removable for future use if desired for gas hose routing.)

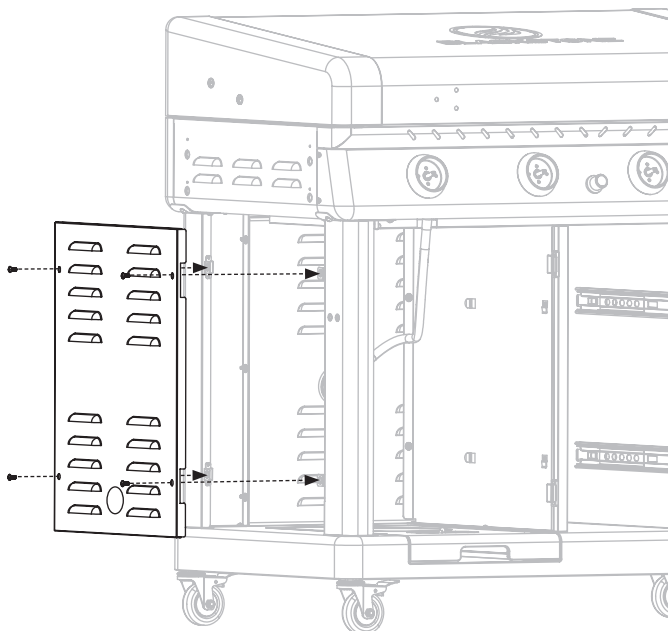

**STEP 14** Use four (4) M5x10 screws [b.] to attach the other side panel to the rear-right leg and front-right leg.

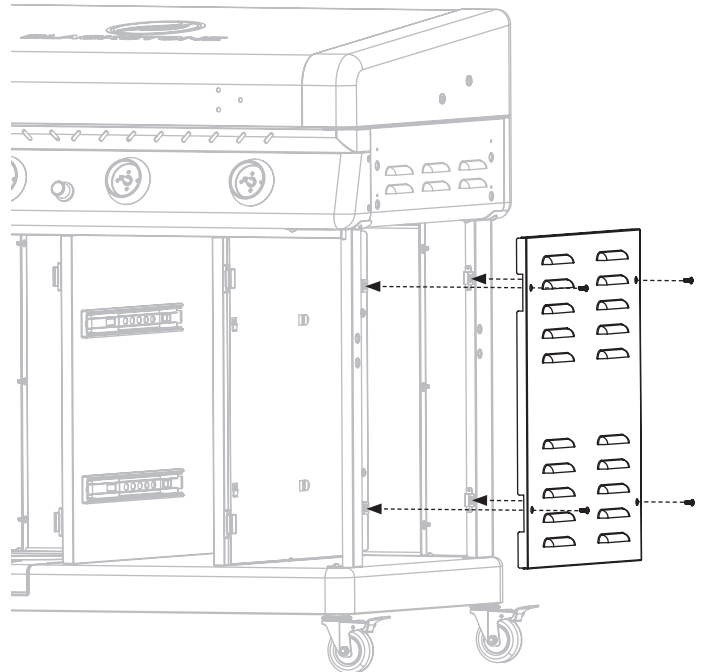

**STEP 15** Use two (2) M6x15 screws [a.] to attach the cart door handle to the left cart door.

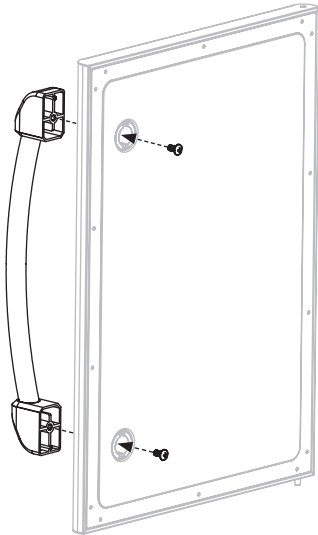

**STEP 16** Attach the left cart door to the cart by first **1** inserting the door into the upper door hinge pin, then **2** inserting the lower door hinge pin into the cart base.

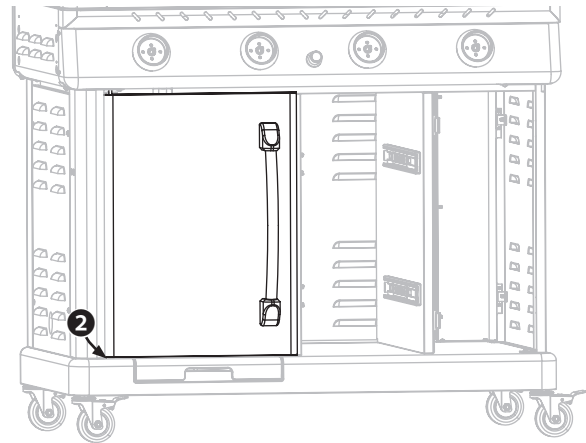
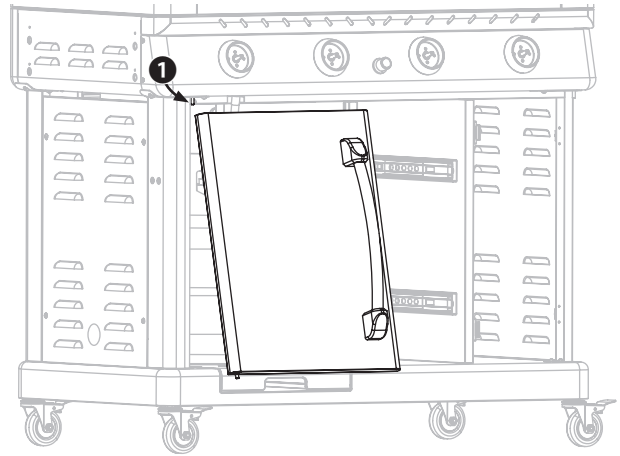

**STEP 17** Attach the right cart door to the cart by first **1** inserting the door into the upper door hinge pin, then **2** inserting the lower door hinge pin into the cart base.

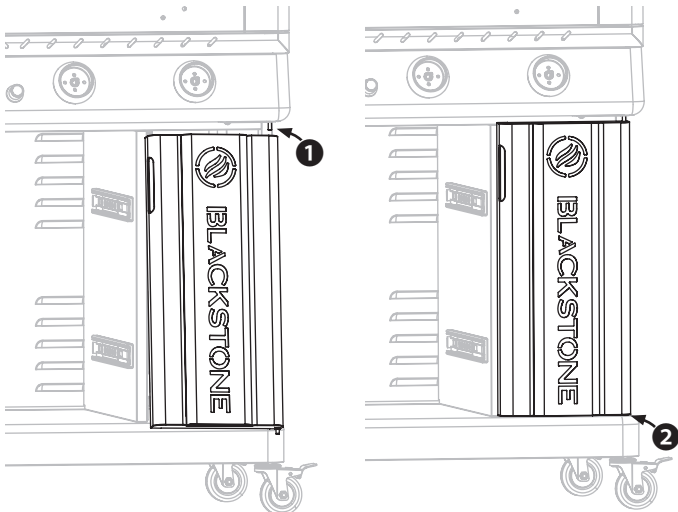

**STEP 18** Use seven (7) M5x10 screws [b.] to attach the lower drawer front panel to the one (1) drawer body.

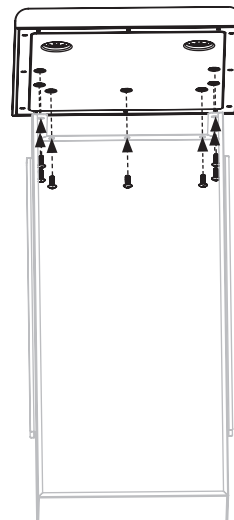



**STEP 19** Insert one (1) drawer handle into two (2) handle standoffs. Use two (2) M6x15 screws [a.] to attach one (1) drawer handle to the lower drawer front panel.

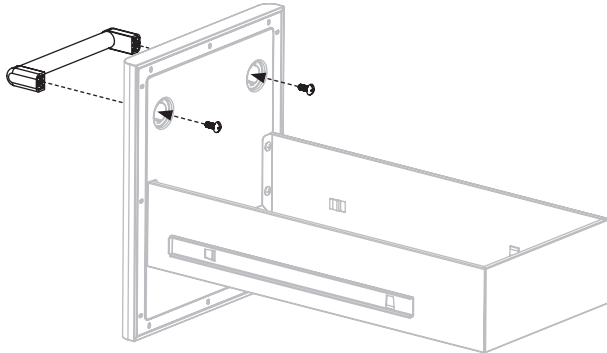

**STEP 20** Use seven (7) M5x10 screws [b.] to attach one (1) drawer body to the upper drawer front panel.

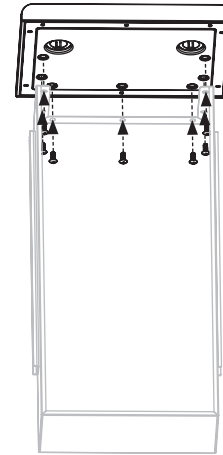

**STEP 21** Insert one (1) drawer handle into two (2) handle standoffs. Use two (2) M6x15 screws [a.] to attach one (1) drawer handle to the upper drawer front panel.

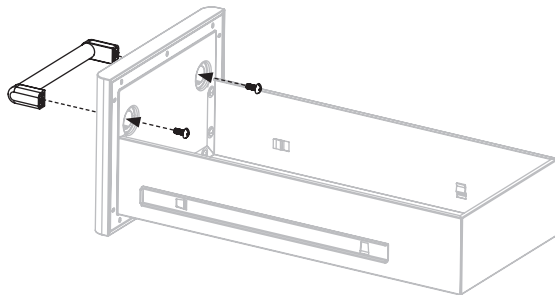

**STEP 22** Pull out the four (4) drawer sliding tracks from the left and right drawer panels. Insert the upper and lower drawer sliding tracks into the cart tracks. (**Note:** the upper drawer front panel is shorter, and the lower drawer front panel is taller.)

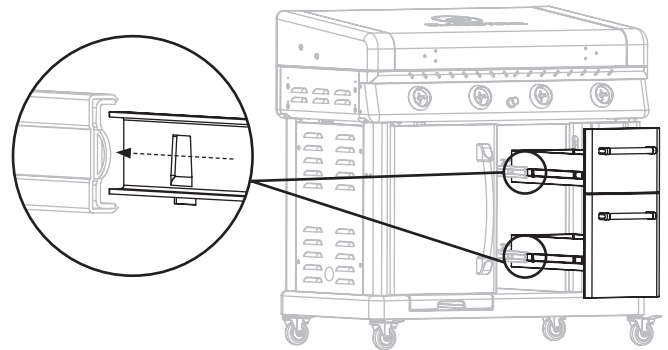

**STEP 23** Use two (2) M5x10 screws [b.] to attach the paper towel holder to the front-left leg.

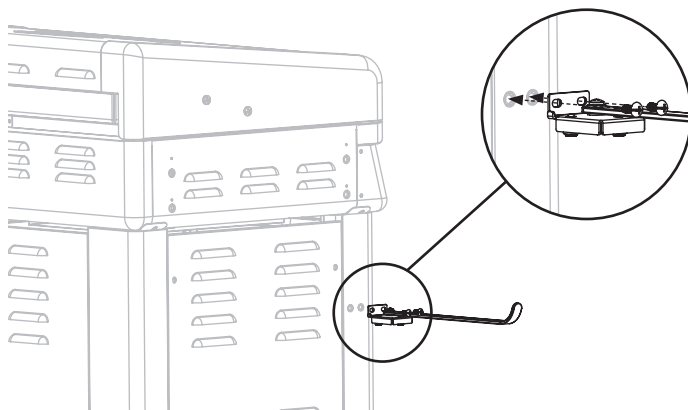

**STEP 24** Use four (4) M6x15 screws [a.] to attach one (1) garbage bag bracket (A) to the front-right leg, and one (1) garbage bag bracket (B) to the back-right leg.

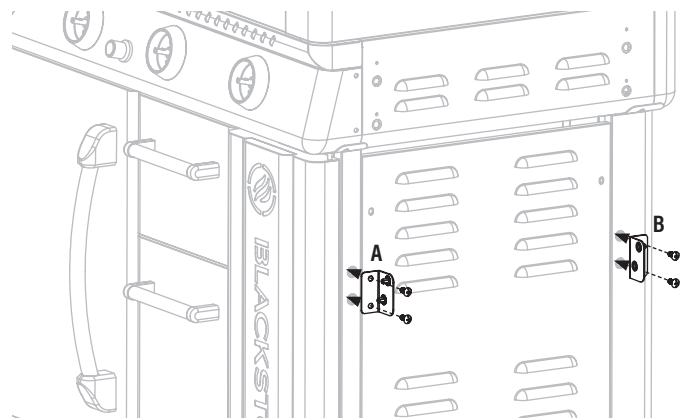

**STEP 25** Use four (4) M5 step bolts [d.] to attach the garbage bag holder to the garbage bag holder brackets.

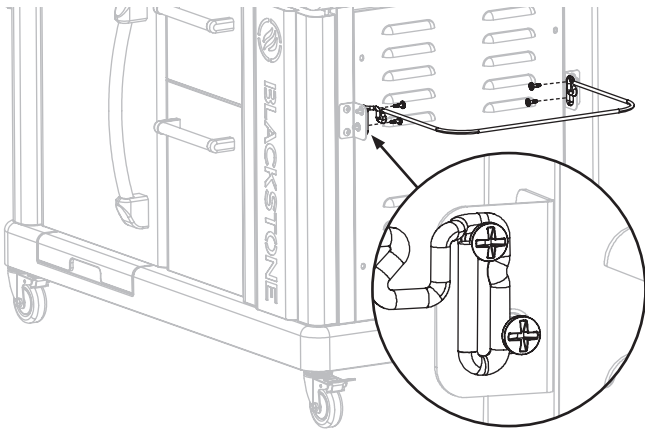

**STEP 26** Use eight (8) M6x15 screws [a.] to install the four (4) side shelf brackets. (One side shelf bracket (A) and one side shelf bracket (B) per side.)

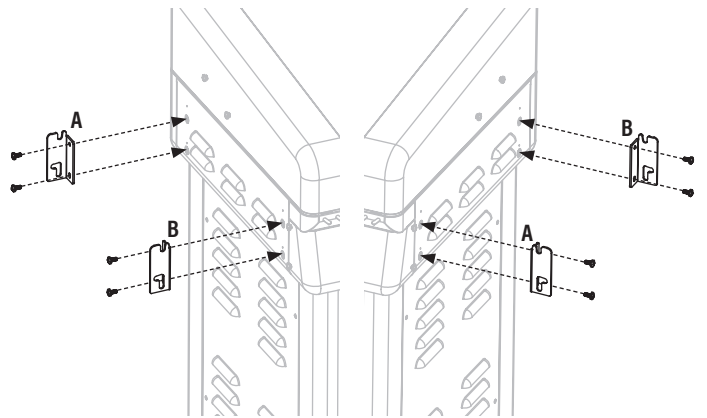

**STEP 27** Screw two (2) small M6 step bolts [e.] into the top holes of the left side shelf. Repeat with the right side shelf.

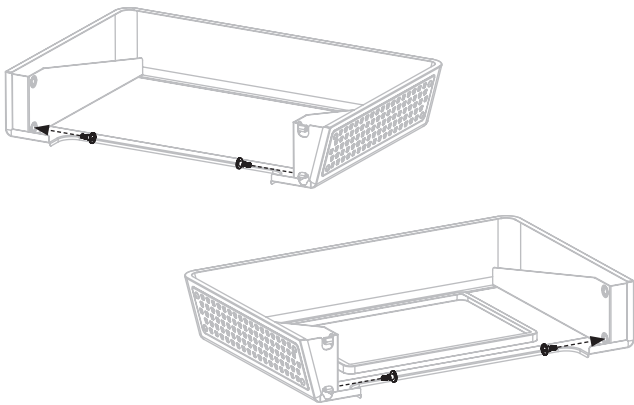

**STEP 28** Hook the left side shelf's M6 step bolts onto the shelf brackets on the left side of the griddle. Secure the shelf with two (2) small M6 step bolts [e.] in the bottom holes of the shelf brackets. Repeat with the right side shelf.

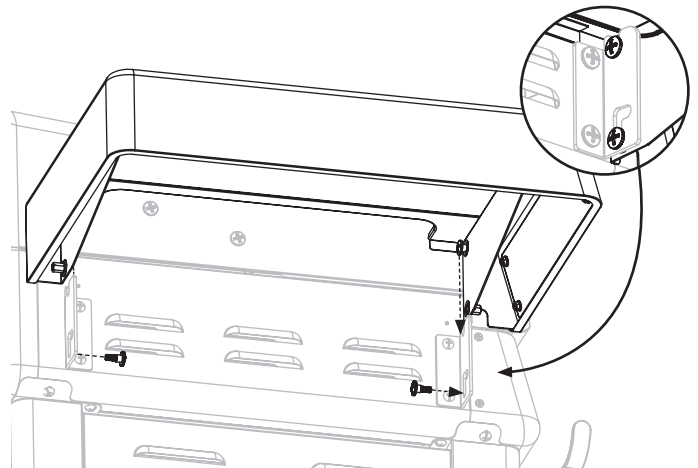

**STEP 29** Place the cutting board on the right side shelf.

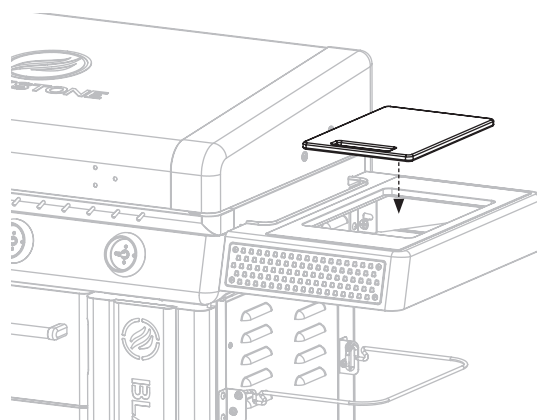



**STEP 30** Install the four (4) control knobs by pushing them into place in the OFF position.

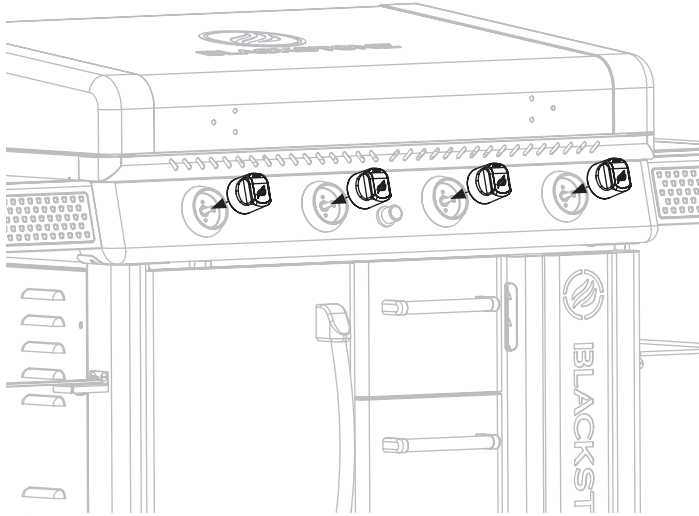

**STEP 31** Insert the hood handle into the two (2) handle standoffs. Use six (6) large M6 step bolts [f.] to attach the handle to the griddle hood.

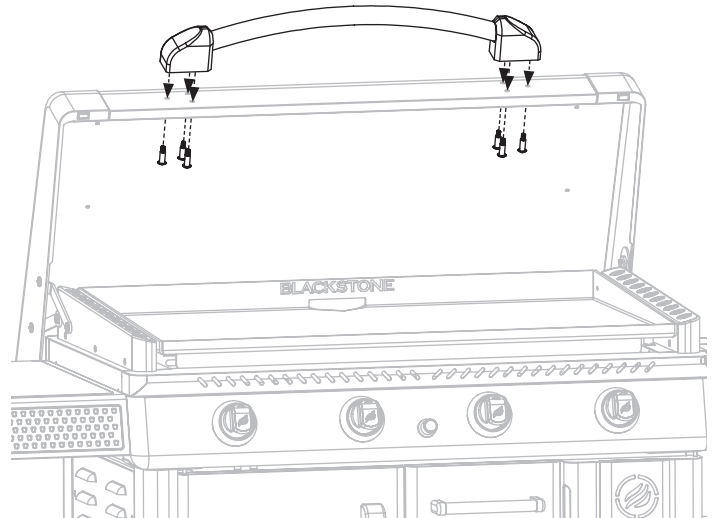

**STEP 32** Open the hood. With the help of another person, place the griddle top on the main body by aligning the four (4) pins to the holes of the body.

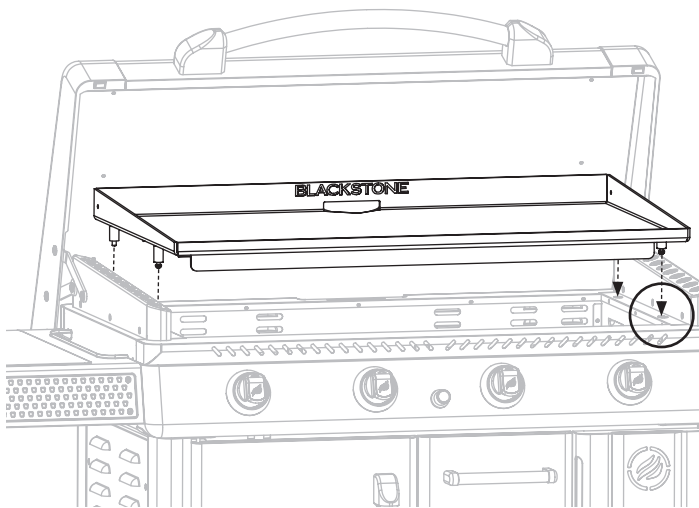

Make sure the front pins are seated in the holes, then push the griddle top back.

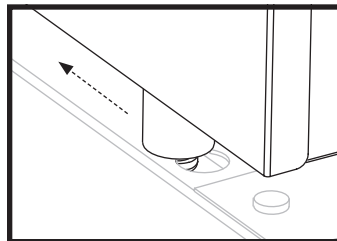

**STEP 33** Hang the rear grease cup with grease cup liner on the back of the unit.

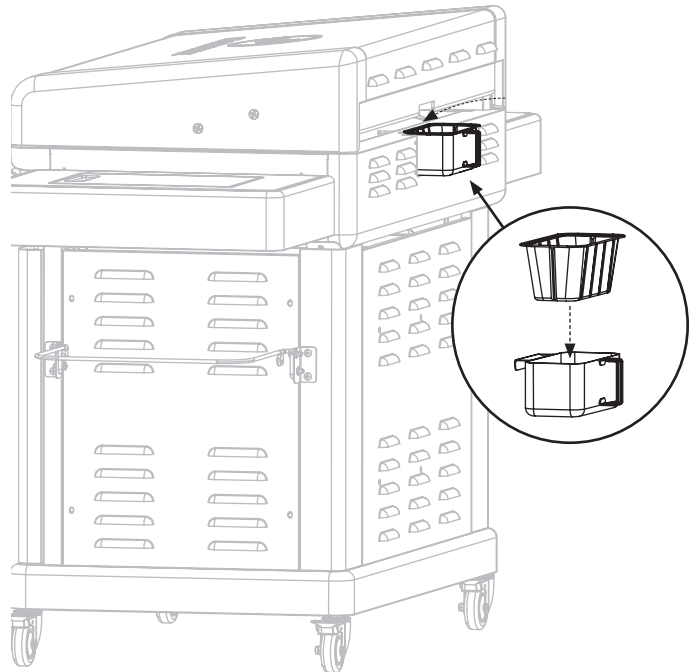

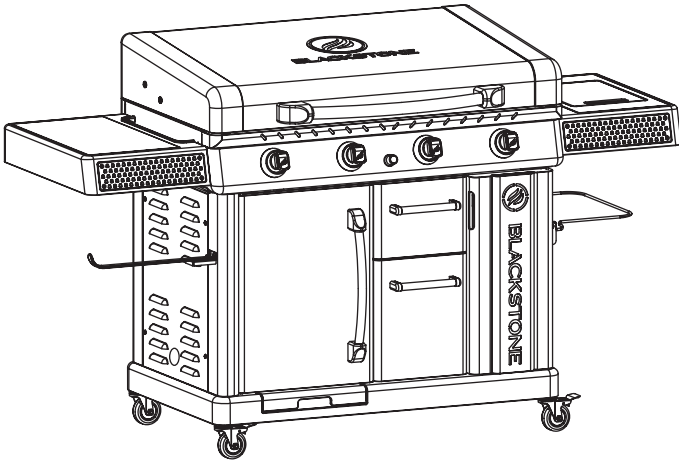
**STEP 34** Proceed to **USING YOUR BLACKSTONE.****NOTICE**

DO NOT leave the hood closed for more than 10 minutes while cooking.

**NOTICE**

- Maximum weight on the side shelf is 10 lbs (4.5 kg).
- The side shelf may get hot while appliance is in use.



# USING YOUR BLACKSTONE

## BEFORE COOKING

### CHECK BURNERS

Prior to connection and use, ensure that there is no debris caught in, or damage to, the head of the gas cylinder, regulator, hose, burner and burner ports.

Spiders and insects can nest within and clog the burner/venturi tube at the orifice.

Please reference the Troubleshooting chapter for burner cleaning instructions.

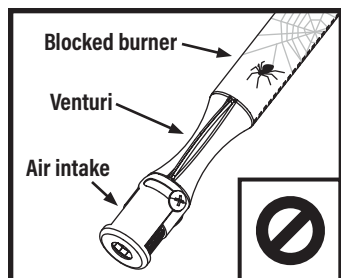

**⚠ WARNING**  
A clogged burner can lead to a fire beneath the appliance. Burner should be removed and cleaned whenever blockages are found.

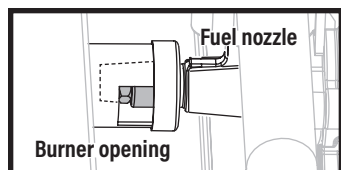

**⚠** Ensure that the gas rail fuel nozzle orifice is correctly engaged within the burner opening.

**⚠ DANGER**  
Flammable items can combust if placed near the appliance. Keep the appliance area clear and free from combustible materials, aerosol containers, gasoline and other flammable vapors and liquids.

**THE MINIMUM AMBIENT OPERATING TEMPERATURE IS 0°F (-18°C).**

## SETTING UP YOUR OUTDOOR SPACE

**THIS APPLIANCE MUST ONLY BE USED OUTDOORS.**

- DO NOT use this appliance inside buildings, garages, or any other enclosed area.
- DO NOT install this appliance in or on a boat.
- DO NOT install this appliance in or on a recreational vehicle.

**MAINTAIN PROPER CLEARANCES FROM COMBUSTIBLE MATERIAL.**

- DO NOT use this appliance on or under any apartment or condominium balcony or deck.
- DO NOT obstruct the flow of combustion and ventilation air.
- DO NOT operate this appliance any closer than 36 in (1 m) from the sides and back of the appliance to combustible construction.

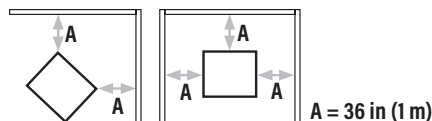

- DO NOT use this appliance under overhead combustible construction.

### SHELTERED OUTDOOR AREAS:

All openings must be permanently open; sliding doors, garage doors, windows or screened openings are not considered as permanent openings.

An appliance is considered to be outdoors if installed with shelter no more inclusive than:

- a. With walls on three sides, but with no overhead cover.

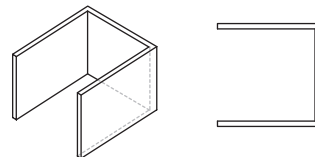

- b. Within a partial enclosure that includes an overhead cover and no more than two sidewalls. The sidewalls may be parallel, as in a breezeway, or at right angles to each other.

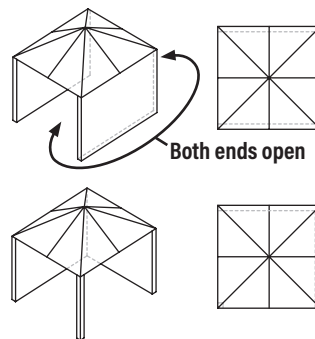

- c. Within a partial enclosure that includes an overhead cover and three sidewalls, as long as 30% or more of the horizontal periphery of the enclosure is permanently open.

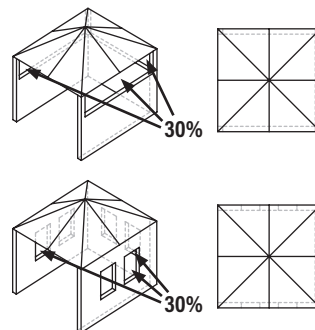

## LPG CYLINDER REQUIREMENTS

### FOR 20 LB (9 KG CYLINDERS)

- The LPG supply cylinder to be used must be constructed and marked in accordance with the specifications for LP gas cylinders, U.S. Department of Transportation (DOT) or the Standard for Cylinders, Spheres and Tubes for the Transportation of Dangerous Goods, CAN/CSA-B339.
- Only LPG cylinders marked "propane" shall be used.
- The LPG cylinder supply system must be arranged for vapor withdrawal.
  - Always keep new LPG cylinders in upright position during use, transit or storage.
  - Always keep the ventilation opening(s) of the cylinder enclosure free and clear from debris.

### THE LPG CYLINDER VALVE MUST HAVE:

- Type 1 valve outlet (thread on the outside).
- Safety relief valve.
- UL listed Overfill Protection Device (OPD). This OPD safety feature is identified by a unique triangular hand wheel.
- Dust cap.

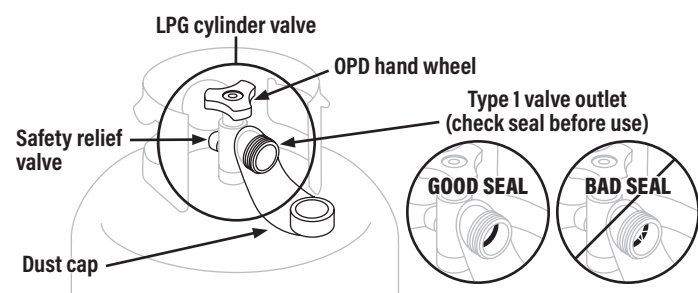

The seal on the type 1 valve outlet could, over time, show marked and visible damage or deterioration that might cause a leak even with the connection tightened.

- A visual inspection for the seal must be carried out every time a LPG cylinder is replaced or refilled.
- Any LPG cylinder showing signs of damage or deterioration as those illustrated including visible cracks and pitting, must be returned unused to the seller.

## STORING LPG CYLINDERS

### ⚠ WARNING

- DO NOT store a spare LPG cylinder under or near this appliance.
- DO NOT fill an LPG cylinder beyond 80% full.

If the information above is not followed exactly, a fire causing death or serious injury may occur.

- The LPG cylinder must be turned OFF when the appliance is not in use.
- LPG cylinders must be stored outdoors and out of the reach of children.
- DO NOT store an LPG cylinder inside a building, garage, or any other enclosed area.

## FILLING & EXCHANGE

- Use only those reputable exchange companies that inspect, precision fill, test and certify their cylinders. LPG dealer must purge new cylinder before filling.
- Volume of propane in cylinder will vary by temperature.

### ⚠ WARNING

A frosty regulator indicates gas overfill. Immediately close LPG cylinder valve and call local LPG dealer for assistance.

- DO NOT release liquid petroleum gas (LPG) into the atmosphere.
- To remove gas from LPG cylinder, contact a certified LPG dealer or local fire department for assistance.
- Exchange cylinder only for an OPD safety feature-equipped cylinder.

Your retailer can help you match a replacement LPG cylinder to your appliance.

## LEAK TEST INSTRUCTIONS

- Leak test new and exchanged LPG cylinders BEFORE connecting to griddle.
- DO NOT smoke during leak test.
- DO NOT use an open flame to check for gas leaks.
- Appliance must be leak tested outdoors in a well-ventilated area, away from ignition sources such as gas fired or electrical appliances.
- During leak test, keep appliance away from open flames or sparks.

### LEAK TEST: LPG CYLINDER

**STEP 01** Use a clean paintbrush to brush a 1% mild soap and water solution onto joint areas of the LPG cylinder. (Indicated by arrows in figure 01.)

- Leaks are indicated by growing bubbles.

### ⚠ WARNING

If growing bubbles appear during leak test, DO NOT use or move the LPG cylinder. Immediately contact an LPG supplier or fire department.

figure 01

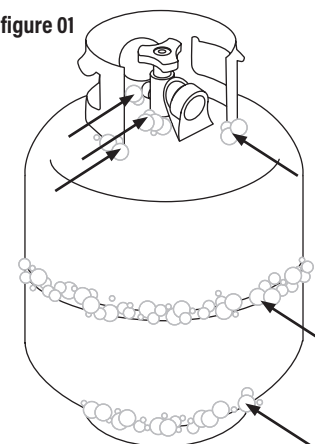

## FITTINGS & HOSES

- Annual checking and tightening of metal fittings is recommended.
- Keep the fuel supply hose away from any heated surfaces.
- Before each use, check to see if hoses are cut or worn.
- Replace damaged hose before using appliance. (Use only Blackstone approved valve, hose, or regulator. Failure to comply will void the warranty.)





## REGULATOR SAFETY

- Use this appliance, as purchased, only with gas and regulator/valve assembly supplied. DO NOT use quick connect fittings or other add-ons.
- DO NOT cross thread (force at an improper angle) the connection between your LPG cylinder and regulator.
- If you can not connect the regulator, DO NOT use the regulator.

Regulator must be replaced with a Blackstone approved model by a professionally licensed, authorized dealer.

## CONNECT THE LPG CYLINDER ONLY USE A 20 LB (9 KG) CYLINDER

**STEP 01** Turn the control knobs to OFF.

- 1 Ensure that the LPG cylinder is OFF by turning the OPD hand wheel clockwise to a full stop.
- 2 Remove the safety cap from the Type 1 valve outlet.

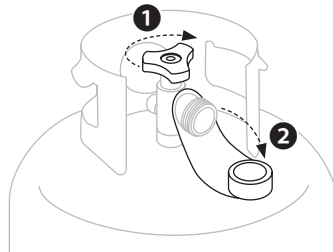

**STEP 02** Hold the regulator in a straight line with the Type 1 valve outlet so as not to cross thread the connection.

Center and insert the regulator nipple into the Type 1 valve outlet.

Hand-tighten the coupling nut in a clockwise direction.

(DO NOT use tools to connect.)  
If connection cannot be completed, disconnect regulator and repeat this step.

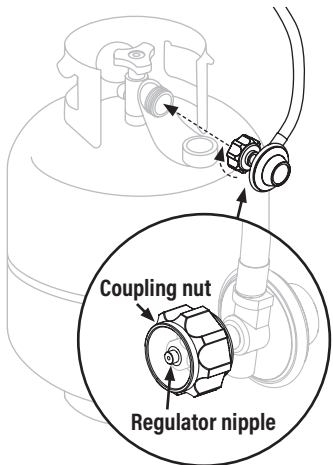

**STEP 03** Open the cart door and pull out the gas tank sliding tray. Then, place the LPG cylinder on the tray. Secure the LPG cylinder by turning the mounting screw clockwise. Push the tray back into the cart.

The safety relief valve must face away from the user while the appliance is in use.

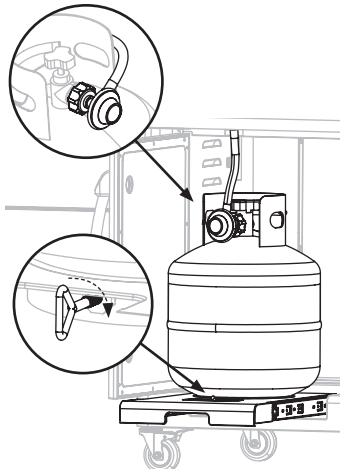

## LEAK TEST: VALVES, HOSE & REGULATOR

**STEP 01** Turn the control knobs to OFF.

**STEP 02** Connect the regulator to the LPG cylinder.

**STEP 03** Completely open the LPG tank by turning the OPD hand wheel counterclockwise.

- If you hear a rushing sound, turn gas off immediately. There is a major leak at the connection.
- Immediately close the LPG cylinder by turning the OPD hand wheel clockwise and re-tighten connections. If leaks cannot be stopped DO NOT TRY TO REPAIR.

**STEP 04** Use a clean paintbrush to brush a 10% mild soap and water solution onto joint areas of valves and regulator.

(Indicated by arrows in figure 02.)

- Leaks are indicated by growing bubbles.
- Immediately close the LPG cylinder by turning the OPD hand wheel clockwise and re-tighten connections.

figure 02

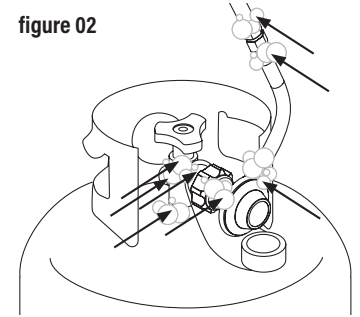

### ⚠ WARNING

If leaks cannot be stopped, DO NOT try to repair.  
Regulator must be replaced with a Blackstone approved model by a professionally licensed, authorized dealer.

## DISCONNECTING THE LPG CYLINDER

**STEP 01** Ensure that the control knobs are turned to OFF.

1 Ensure that the LPG cylinder is OFF by turning the OPD hand wheel clockwise to a full stop.

2 Turn the coupling nut counterclockwise by hand to remove the regulator. (DO NOT use tools to disconnect.)

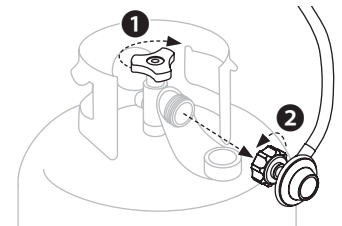

**STEP 02** Place dust cap on LPG cylinder valve outlet whenever cylinder is not in use.

Only install the type of dust cap on cylinder valve outlet that is provided with the cylinder valve. Other types of caps or plugs may result in leakage of propane.

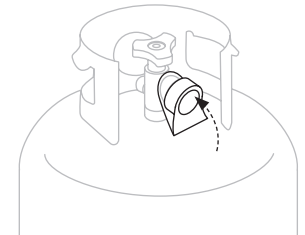

# IGNITION INSTRUCTIONS

## 1. CHECK VALVES

**STEP 01** Turn knob to OFF position.

**STEP 02** Push in knob and release. Knob should spring back. If knobs DO NOT spring back, replace valve assembly before using appliance.

**STEP 03** Rotate knob to LOW then turn back to OFF. Knob should turn smoothly.

### ⚠ WARNING

If burner does not ignite with open gas supply valve, gas will continue to flow out of burner and could accidentally/inadvertently ignite with risk of injury.

Ensure gas is off at the supply shut off valve before checking appliance valves.

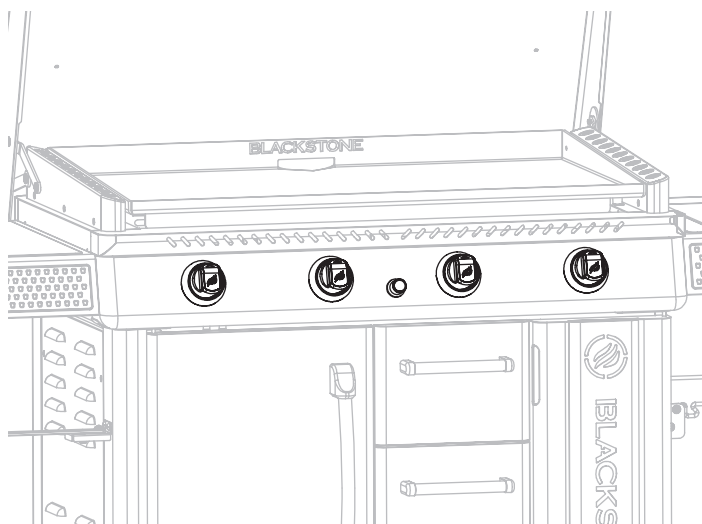

## 3. ALWAYS CHECK BURNER FLAME BEFORE USE.

**STEP 01** Light burners and rotate knobs from HIGH to LOW.

**STEP 02** Look below the cooking surface to view burners. When knob is at HIGH, flames should be larger than when knob is at LOW.

### HEALTHY FLAME PATTERN

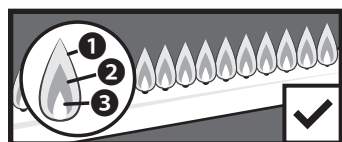

- 1 Flickers of yellow color.
- 2 Dark blue color.
- 3 Vibrant blue.

### YELLOW OR IRREGULAR

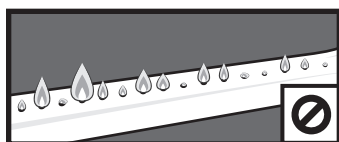

If there is a sudden drop or low flame issue, please reference the Troubleshooting chapter.

## 2. BATTERY POWERED IGNITION

⚠ DO NOT lean over the appliance while lighting.

**STEP 01** Insert one (1) AA battery (not included) under the ignitor button.

Screw the button into place over the positive terminal.

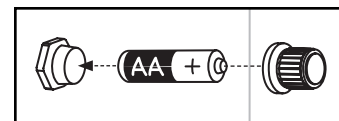

### STEP 02

1 Turn the control knob to OFF.

Turn gas ON by turning the gas cylinder handwheel counter-clockwise 1 to 3 turns.

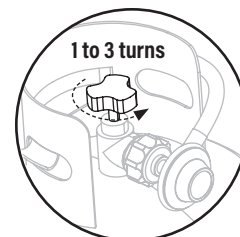

### STEP 03

2 Push and hold the ignitor button.

3 Push and turn the control knob counter-clockwise to HIGH. (Release the ignitor button when the burner lights.)

4 Adjust the temperature to desired level.

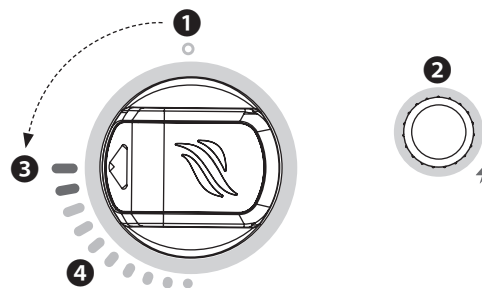

### IF IGNITION DOES NOT OCCUR IN 5 SECONDS:

**STEP 01** Turn the burner control knob OFF.

**STEP 02** Wait 5 minutes.

**STEP 03** Repeat the lighting procedure.

If burner does not ignite, please reference the Troubleshooting chapter.



# GRIDDLE SEASONING INSTRUCTIONS

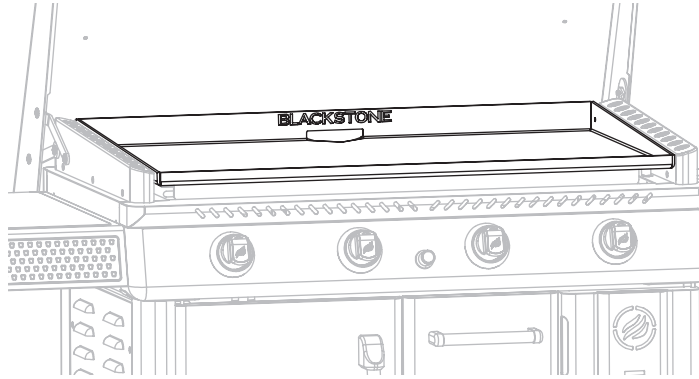

## WASHING YOUR GRIDDLE TOP BEFORE FIRST USE

### NOTICE

Soap will ruin a seasoned griddle. This is the only time you should use soap on the griddle cooking surface.

**STEP 01** Wash the griddle cooking surface with hot, soapy water.

**STEP 02** Rinse and dry completely.

## SEASONING YOUR GRIDDLE



### VIDEO TUTORIAL

How to Season a New Blackstone Griddle  
[youtube.com/watch?v=VspmDVnj2pl&t=3s](https://www.youtube.com/watch?v=VspmDVnj2pl&t=3s)

**STEP 01** Wipe any debris off griddle top.



**STEP 02** Set your griddle to high heat until your griddle top changes color. (~10 min)



**STEP 03** Use tongs to hold a paper towel or cotton cloth and spread 2-3 tablespoons of your seasoning oil across the entire griddle top.  
 When seasoning your griddle top, remember to use a thin and even layer of oil—the thinner the layer of oil, the easier it will be to burn it off.



**STEP 04** The griddle top is ready for another layer of oil when it stops smoking. Repeat **STEP 03** 3-4 times, or until the griddle surface is black.



### WHAT OIL IS BEST TO USE?

- Blackstone Seasoning and Cast Iron Conditioner.
- Any plant-based cooking oil.
- Rendered animal fat with no additives.



### CAUTION

Properly dispose of the rags/towels used to spread oil on your griddle top for seasoning purposes to prevent fires that might occur due to spontaneous combustion.

Under the right conditions, residual oil on rags or towels can oxidize long after being removed from a heat source. The oxidation process itself produces heat which, if not dissipated, can build up and cause combustible materials (including the rags/towels themselves) to ignite.

## SEASONING TROUBLESHOOTING

### THERE IS A BROWNISH RESIDUE ON THE GRIDDLE SURFACE:

#### POSSIBLE CAUSES

- Too much oil was used.
- You turned off the heat too soon.

#### SOLUTION

- STEP 01** Turn your griddle on high and let it heat for 10-15 minutes.
- STEP 02** Scrape off as much of the thickened and partially cooked oil as you can.
- STEP 03** Re-season with a very thin layer of oil.

### THE EDGES OF THE GRIDDLE SURFACE ARE NOT BLACK:

After using your griddle for multiple cooks, the seasoning will even out and improve.

## PREVENTING RUST

Use your griddle frequently. Every time you cook, you are adding to the seasoning, which makes rust less likely.

### NOTICE

If you live in a humid or coastal climate, your griddle may require more frequent seasonings between uses.

If rust appears on the griddle surface, rub it off with steel wool, low grit sandpaper or the **Blackstone Pumice Stone** and re-season the surface.



### VIDEO TUTORIAL

Recovering your Blackstone Griddle Top  
[youtube.com/watch?v=thPE2lgnSil](https://www.youtube.com/watch?v=thPE2lgnSil)

## COOKING ON YOUR BLACKSTONE

### ⚠ CAUTION

This appliance will be hot during and after use. Use long-handled utensils and oven mitts/ protective gloves when handling potentially hot parts to protect against burns and splatters.

### ⚠ CAUTION

If the appliance is fitted with a paper towel holder, the arm must be in the open position while the appliance is in use.

### NOTICE

DO NOT store any items within 3 in (8 cm) of the cooking surface while in use.

### IF GREASE OR OTHER HOT MATERIAL DRIPS ONTO VALVE, HOSE OR REGULATOR:

**STEP 01** Turn off gas supply immediately.

**STEP 02** Determine the cause and correct it.

**STEP 03** Clean and inspect valve, hose and regulator.

**STEP 04** Perform a leak test. (Please reference the Leak Test Instructions)

### VIDEO RECIPES

Find recipes and cooking tips at:

[BlackstoneProducts.com/recipes](https://www.blackstoneproducts.com/recipes)

[youtube.com/BlackstoneGriddles](https://www.youtube.com/BlackstoneGriddles)

[@blackstoneproducts](https://www.facebook.com/blackstoneproducts)



**STRAWBERRIES AND CREAM PANCAKES**  
Breakfast

**OKLAHOMA FRIED ONION BURGER**  
Lunch



**TACOS BORRACHOS**  
Dinner

### CLEANING YOUR GRIDDLE TOP

Clean griddle top after each use, while still warm.

• DO NOT use soap on the griddle top. This will destroy the griddle's seasoning.



#### VIDEO TUTORIAL

How to Clean your Blackstone Griddle

[youtube.com/watch?v=-ledu9z6NPY](https://www.youtube.com/watch?v=-ledu9z6NPY)

**STEP 01** Push loose food debris into the grease cup with spatula or straight metal scraper.



**STEP 02** Wipe down griddle top with paper towel.



**STEP 03** Apply a few tablespoons of water to the griddle surface, then scrape the water and debris into the grease cup.

(For stuck-on food residue, use a bit of coarse salt.)



**STEP 04** Wipe again with a paper towel and dry completely.



**STEP 05** Apply thin coat of cooking oil to maintain seasoning and protect the griddle top.



### EMPTY YOUR GREASE CUP

The grease cup must be removed and emptied after each use.

### ⚠ CAUTION

Grease cup will be hot during and after use. DO NOT remove the grease cup until the griddle has completely cooled.



## CARE AND MAINTENANCE

### ⚠ WARNING

Grease build up can cause a fire. Clean any part of the appliance that gets hot and experiences grease build up after each use.

### ⚠ CAUTION

All cleaning and maintenance should be carried out when the appliance is cool and everything is turned OFF.

- DO NOT use abrasive pad on areas with graphics.
- If a bristle brush is used to clean any of the cooking surfaces, ensure no loose bristles remain on cooking surfaces prior to cooking.

#### **APPLIANCE BODY:**

Wash with warm soapy water and immediately wipe dry with a non-abrasive cloth. (DO NOT allow cleaning agents to rest on any porous surface for a prolonged amount of time.)

### **NOTICE**

DO NOT use Citrisol, abrasive cleaners, or a concentrated cleaner on the appliance. This may result in damage to and failure of parts.

## APPLIANCE STORAGE

### ⚠ WARNING

DO NOT move the appliance when in use. Allow the appliance to cool to 115°F (45°C) before moving or storing.

Storage of an appliance indoors is only permissible if the gas supply is disconnected and removed from the appliance.

#### **COVER FIT GUIDE**

Always cover your appliance when stored outdoors.



To find a cover that will fit your appliance, visit [BlackstoneProducts.com/support](https://BlackstoneProducts.com/support).

# TROUBLESHOOTING

## IGNITION TROUBLESHOOTING

### BURNER WILL NOT IGNITE:

If ignition does not occur in 5 seconds:

**STEP 01** Turn the burner control knob OFF.

**STEP 02** Wait 5 minutes.

**STEP 03** Repeat the lighting procedure.

If this does not work, to determine the cause, please try to ignite your appliance with a match.

### MATCH LIGHTING INSTRUCTIONS

Before beginning, check for gas leaks. Open hood (if applicable).

**STEP 01** Turn control knob to OFF position.

**STEP 02** Light a match (or long lighter) no shorter than 11 inches long.

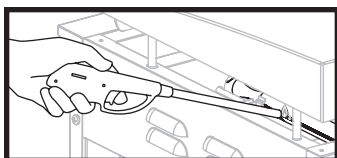

**STEP 03** Place the flame next to the burner.

**STEP 04** Push in and turn the control knob to start gas flowing. Ensure burner lights and stays lit.

### IF YOU CAN IGNITE YOUR APPLIANCE WITH A MATCH:

POSSIBLE CAUSES	SOLUTION
Ignitor wire misaligned.	Ensure that the ignitor needle is positioned 3-7mm away from the burner, and aligned with the burner holes.
Damage to the ignition system.	Contact customer support for replacement parts.
Dead / improperly installed battery.	Replace with new battery.

### IF YOU CAN NOT IGNITE YOUR APPLIANCE WITH A MATCH:

POSSIBLE CAUSES	SOLUTION
Burner tubes are not receiving fuel.	Clean the burner assembly to remove the obstruction.

## GAS FLOW TROUBLESHOOTING

### BURNER FLAMES ARE YELLOW OR IRREGULAR:

- Appliance will not achieve a high heat or heats unevenly.
- Burner flames start strong, then immediately drop to low even when burner is set to high position.
- Flame height drops when a second burner is lit.
- Flames DO NOT extend the full length of the burner, or only run on one side of the burner.
- Burner flames are inconsistent.

POSSIBLE CAUSES	SOLUTION
Obstructions in the burner, gas jets, or fuel rail.	Clean the burner, jets, and gas hose.
Gas cylinder is empty or low.	Refill or replace the gas cylinder.
The regulator's flow limiting device was triggered.	Reset the safety system: <b>STEP 01</b> Turn OFF the appliance, close the LPG cylinder valve, and disconnect the regulator from the LPG cylinder. <b>STEP 02</b> Wait five minutes to allow the pressure to dissipate, then reconnect the regulator to the LPG cylinder and slowly open the OPD hand wheel one half turn. <b>STEP 03</b> Ignite your appliance.
Regulator stuck in safety position.	Contact customer support for replacement parts.

### A FLAME IS COMING OUT OF THE AIR GATE:

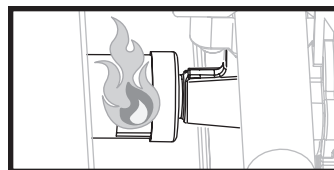

POSSIBLE CAUSES	SOLUTION
Something is blocking the venturi in the burner.	Clean the burner assembly to remove the obstruction.



## CLEANING THE BURNER ASSEMBLY

To reduce chance of “flash-back” the procedure below should be followed at least once a month when spiders are most active or when your appliance has not been used for a period of time.



### VIDEO TUTORIAL

How to Clean Your Burner Tube

[youtube.com/watch?v=xKQTCrFCzf8](https://www.youtube.com/watch?v=xKQTCrFCzf8)

**STEP 01** Ensure that the gas is turned OFF at control knobs and gas supply. Remove the griddle top.

**STEP 02** Carefully detach and remove the burner.



**STEP 03** Clean the inside of the burner:

- a. Run a bottle brush (not a wire brush) or a stiff wire bent into a small hook through each burner tube several times.
- b. Use compressed air to blow through the burner tube and out the burner ports (Wear eye protection).



**STEP 04** Brush entire outer surface of burner to remove grime.



**STEP 05** Clean any blocked ports with stiff wire such as an open paper clip.



**STEP 06** Carefully replace burners and reattach, with attention to the location of the ignition needle.

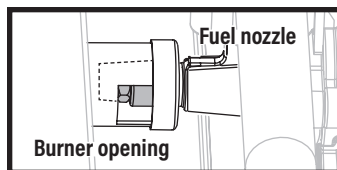

**⚠** The gas rail fuel nozzle must be reengaged within the burner opening.

## CUSTOMER SUPPORT

Visit us online at [BlackstoneProducts.com/support](https://www.BlackstoneProducts.com/support) for assistance concerning appliance use, replacement parts, or your warranty.

### CUSTOMER SUPPORT HOURS:



Monday – Friday  
7:00 am – 5:00 pm (Mountain Time)



This product may be covered by one or more issued U.S. and/or international patents and may include patent applications pending. For more information, please visit: [BlackstoneProducts.com/patents](https://BlackstoneProducts.com/patents)