

# Owner's Manual

## Operation & Care

**INSTALLER:** Leave this manual with party responsible for use and operation.  
**OWNER:** Retain this manual for future reference.

Contact your dealer with questions on installation, operation, or service.

# QUADRA-FIRE®

## PELLET BURNING APPLIANCE

**MODEL NUMBER:  
OUTFITTER-II**

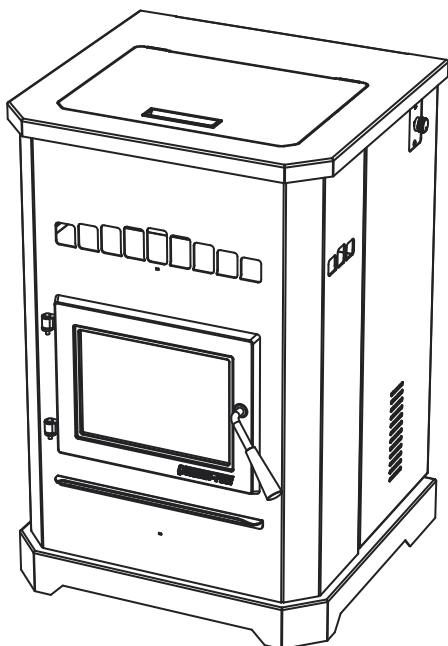

### CAUTION

Tested and approved for wood pellets, Burning of any other type of fuel voids your warranty.

Installation and service of this appliance should be performed by qualified personnel. Hearth & Home Technologies recommends HHT Factory Trained or NFI certified professionals.



### WARNING



If the information in these instructions is not followed exactly, a fire could result causing property damage, personal injury, or death.

- Do not store or use gasoline or other flammable vapors and liquids in the vicinity of this or any other appliance.
- Do not over fire - If appliance or chimney connector glows, you are over firing. Over firing will void your warranty.
- Comply with all minimum clearances to combustibles as specified.

Failure to comply may cause house fire.



### WARNING



#### HOT SURFACES!

Glass and other surfaces are hot during operation AND cool down.

Hot glass will cause burns.

- Do not touch glass until it is cooled
- NEVER allow children to touch glass
- Keep children away
- CAREFULLY SUPERVISE children in same room as fireplace.
- Alert children and adults to hazards of high temperatures
- **High temperatures may ignite clothing or other flammable materials.**
- Keep clothing, furniture, draperies and other flammable materials away.



### CAUTION

Check building codes prior to installation.

- Installation MUST comply with local, regional, state and national codes and regulations.
- Consult local building, fire officials or authorities having jurisdiction about restrictions, installation inspection, and permits.

**NOTE:** To obtain a French translation of this manual, please contact your dealer or visit [www.quadrafire.com](http://www.quadrafire.com).

**REMARQUE :** Pour obtenir une traduction française de ce manuel, s'il vous plaît contacter votre revendeur ou visitez [www.quadrafire.com](http://www.quadrafire.com).

# Congratulations

and Welcome to the Quadra-Fire Family!

**NOTE:** Clearances may only be reduced by means approved by the regulatory authority having jurisdiction

## A. Sample of Serial Number / Safety Label

LOCATION: Back of appliance

Test Lab  
and Report  
Number

**Model Name**

**CAUTION: HOT WHILE IN OPERATION DO NOT TOUCH. KEEP CHILDREN, CLOTHING AND FURNITURE AWAY. CONTACT MAY CAUSE SKIN BURNS. SEE NAMEPLATE AND INSTRUCTIONS.**

**ATTENTION: CHAUD LORS DE L'OPÉRATION. NE PAS TOUCHER. L'ESPACE DESIGNÉ DE L'INSTALLATION. LE CONTACT PEUT CAUSER DES BRÛLURES À LA PEAU. VOIR L'ÉTIQUETTE ET LES INSTRUCTIONS.**

**UL LISTED**  
Solid Fuel Type Room Heater  
Issue No. MH5063

**Outfitter-II Pellet Stove**

Serial No. /  
N° de série: **VN**

**BARCODE LABEL**

Listed Solid Fuel Room Heater/Pellet Type. Also suitable for Mobile Home Installation.  
Appareil de chauffage de combustible solide/de type de bouillettes. Accepté dans l'installation dans les maisons mobiles.  
Listado de habitaciones de combustible sólido del calentador / Pellet Tipo. También es adecuado para la instalación de casas móviles.

**PREVENT HOUSE FIRES / PRÉVENTION DES FEUX DE MAISON**  
Install and use only in accordance with manufacturer's installation and operating instructions. Contact local building or fire officials about restrictions and installations inspection in your area.  
**WARNING - FOR MOBILE HOMES:** Do not install appliance in a sleeping room. An outside combustion air inlet must be provided. The structural integrity of the mobile home floor, ceiling and walls must be maintained. Refer to manufacturer's instructions and local codes for precautions required for passing chimney through a combustible wall or ceiling. Inspect and clean vent system frequently in accordance with manufacturer's instructions. **DO NOT CONNECT THIS UNIT TO A CHIMNEY SERVING ANOTHER APPLIANCE.** Use a 3" or 4" diameter type "L" or "PL" venting system.  
Installez et utilisez en accord avec les instructions d'installation et d'opération du fabricant. Contactez le bureau de la construction ou le bureau des incendies au sujet des restrictions et des inspections d'installation dans votre voisinage. Ne pas obstruer l'espace en dessous de l'appareil.  
**AVIS - Pour Les Maisons Mobiles:** Ne pas installer dans une chambre à coucher. Un tuyau extérieur de combustion d'air doit être installé et ne doit pas être obstrué lorsque l'appareil est en usage. La structure intégrale du plancher, du plafond et des murs de la maison mobile doit être maintenue intacte. Référez vous aux instructions du fabricant et des codes locaux pour les précautions requises pour passer une cheminée à travers un mur ou un plafond combustibles, et les compensations maximums. Inspectez et nettoyez la cheminée fréquemment. Ne pas connecter cet appareil à une cheminée servant un autre appareil. Utilisez système de ventilation "L" ou "PL" diamètre 76mm ou 102mm.  
Instale y use únicamente de acuerdo con la instalación del fabricante y las instrucciones de funcionamiento. Póngase en contacto con la construcción o de los bomberos para restricciones y la inspección en nuestra área.  
Conforms to ASTM Std E1509-12 (R2017). Certified to ULC S627-00. Room Heating Pellet Burning Type, (UM) 84-HUD FOR USE ONLY WITH PELLETTIZED WOOD. Do not use any other type of fuel.

**Input Rating:** 49,207 Btu/s/hr. Electrical Rating: 120 VAC, 60 Hz, Start 2.6 Amps, Running 2.3 AMPS. Route power cord away from unit. Do not route cord under or in front of unit.

MINIMUM CLEARANCE TO COMBUSTIBLE MATERIALS / ESPACES LIBRES MINIMUM DES MATÉRIAUX COMBUSTIBLES	
A	Back Wall / Mur Arrière / Pared Posterior
B	Fire Wall / Mur De Combustibles / Cordon de Humos
C	Side Wall / Mur De Côté / Muro Lateral
D	Corner Installation / Installation DU COIN / RINCÓN DE LA INSTALACIÓN

(horizontal installation) 3 in [76 mm]  
3 in [76 mm]  
9 in [229 mm]  
3 in [76 mm]

FLOOR PROTECTION / PROTECTION DU SOL / PISO DE PROTECCION	
USA	Canada
G = 2 in H = 2 in I = 6 in	G = 203 mm H = 51 mm I = 152 mm

Non-combustible floor protection must extend 2 inches (51mm) beneath the flue pipe when installed with horizontal venting or under the Top Vent Adapter with vertical installation. RECOMMENDED IN USA; REQUIRED IN CANADA.  
"Un protecteur incombustible de plancher doit s'étendre 2 inches (51mm) sous le conduit de cheminée pour une installation de ventilation horizontale ou sous un adaptateur de ventilation de dessus pour une installation verticale. RECOMMANDE AUX ETATS-UNIS; NÉCESSAIRE AU CANADA.  
"No es combustible mínimo de protección debe extenderse 2 pulgadas (51mm) por debajo del conducto de humos cuando se instalan con la ventilación horizontal o en el adaptador de ventilación superior con instalación vertical. RECOMENDADO EN EE.UU.; REQUERIDA EN CANADA.

**HEARTH & HOME**  
Technologies®  
352 Mountain House Road  
Harrisburg, PA 17032  
1.877.427.3316  
www.quadrafire.com

U.S. ENVIRONMENTAL PROTECTION AGENCY  
Certified to comply with 2020 particulate emission standards at 0.53 g/hr EPM method 28 and 5G. This wood heater needs periodic inspection and maintenance for proper operation. Consult the owner's manual for further information. Use against federal regulations to operate this wood heater in a manner inconsistent with the operating instructions in the owner's manual.

8105-2096A

2022 2023 2024 JAN FEB MAR APR MAY JUN JUL AUG SEP OCT NOV DEC

**DO NOT REMOVE THIS LABEL / NE PAS ENLEVER L'ÉTIQUETTE**

Made in Vietnam / Fabriqué en Vietnam

Serial Number

Manufacturer  
Date

2

8105-804H

03/23

## Safety Alert Key:



- **DANGER!** Indicates a hazardous situation which, if not avoided will result in death or serious injury.
- **WARNING!** Indicates a hazardous situation which, if not avoided could result in death or serious injury.
- **CAUTION!** Indicates a hazardous situation which, if not avoided, could result in minor or moderate injury.
- **NOTICE:** Indicates practices which may cause damage to the appliance or to property.

## TABLE OF CONTENTS

A. Sample of Serial Number / Safety Label . . . . .	2	<b>4 Maintaining &amp; Servicing Your Appliance</b>	
B. Warranty Policy . . . . .	4	A. Proper Shutdown Procedure . . . . .	15
→ C. Quick Start Guide. . . . .	6	B. Quick Reference Maintenance Chart. . . . .	15
<b>1 Listing and Code Approvals</b>		C. General Maintenance. . . . .	16
A. Appliance Safety Certification . . . . .	7	D. High Ash Fuel Content Maintenance . . . . .	19
B. Appliance Emissions Certification . . . . .	7	E. Frequently Asked Questions . . . . .	20
C. BTU & Efficiency Specifications. . . . .	7	F. Glass Replacement . . . . .	20
D. Glass Specifications. . . . .	8	<b>5 Troubleshooting . . . . .</b>	<b>21</b>
E. Electrical Rating (on high) . . . . .	8	<b>6 Reference Materials</b>	
F. Mobile Home Approved . . . . .	8	A. Maintenance and Service Log . . . . .	24
G. Sleeping Room . . . . .	8	B. Service Parts List . . . . .	25
H. California - Prop65. . . . .	8	C. Wiring Diagram . . . . .	28
<b>2 General Information</b>			
A. Fire Safety . . . . .	9		
B. Combustible/Non-Combustible Materials. . . . .	9		
C. Fuel Material and Fuel Storage . . . . .	9		
D. Before Your First Fire. . . . .	9		
<b>3 General Operating Information</b>			
A. General Operating Parts . . . . .	10		
B. Priming the Feed Tube. . . . .	11		
C. Firepot Burn Down. . . . .	11		
D. Shutdown. . . . .	11		
E. Starting Your First Fire . . . . .	11		
F. Fire Characteristics. . . . .	12		
G. Ignition Cycles . . . . .	12		
H. Trim Adjustment. . . . .	12		
I. Clear Space. . . . .	12		
J. Thermostat Controls. . . . .	13		
K. LED Color Coding Chart and Explanation . . . . .	14		

→ = Contains updated information

## B. Warranty Policy

### Hearth & Home Technologies LLC LIMITED LIFETIME WARRANTY

Hearth & Home Technologies LLC (“HHT”) extends the following warranty for HHT gas, wood, pellet and electric hearth appliances (each a “Product” and collectively, the “Product(s)”) and certain component parts set forth in the table below (“Component Part(s)”) that are purchased from a HHT authorized dealer or distributor.

#### **WARRANTY COVERAGE:**

HHT warrants that the Products and their Component Parts will be free from defects in materials and workmanship for the applicable period of Warranty coverage set forth in the table below (“Warranty Period”). If a Product or Component Parts are found to be defective in materials or workmanship during the applicable Warranty Period, HHT will, at its option, repair the applicable Component Part(s), replace the applicable Component Part(s), or refund the purchase price of the applicable Product(s). The maximum amount recoverable under this Warranty is limited to the purchase price of the Product. This Warranty is transferable from the original purchaser to subsequent owners, but the Warranty Period will not be extended in duration or expanded in coverage for any such transfer. This Warranty is subject to conditions, exclusions, and limitations as described below.

#### **WARRANTY PERIOD:**

Warranty coverage begins at the date of installation. In the case of new home constructions, Warranty coverage begins on the date of first occupancy of the dwelling or six months after the sale of the Product(s) by an independent, authorized HHT dealer or distributor, whichever occurs earlier. However, the Warranty coverage shall commence no later than 24 months following the date of Product shipment from HHT, regardless of the installation or occupancy date.

The term “Lifetime” in the table below is defined as: 20 years from the beginning date of warranty coverage for gas appliances, 10 years from the beginning date of warranty coverage for wood and pellet appliances, and 5 years from the beginning of warranty coverage for standalone gas log sets. These time periods reflect the minimum expected useful lives of the designated Component Parts under normal operating conditions.

Warranty Period		HHT Manufactured Appliances and Venting						
Component Parts	Labor	Gas	Pellet	Wood	Electric	Venting	Component Parts Covered by this Warranty	
1 Year		X	X	X		X	All parts including handles, external enameled components and other material except as covered by Warranty Conditions, Warranty Exclusions, and Warranty Limitations listed	
2 Years					X		All parts except as covered by Warranty Conditions, Warranty Exclusions, and Warranty Limitations listed	
2 years			X	X			Igniters, Auger Motors, Electronic Components, and Glass	
		X					Electrical components limited to modules, remotes/wall switches, valves, pilots, blowers, junction boxes, wire harnesses, transformers and lights (excluding light bulbs)	
		X		X			Molded Refractory Panels, Glass Liners	
3 years			X				Firepots, burnpots, mechanical feeders/auger assemblies	
5 years		X					Burners and logs for standalone gas log sets (Vented and Vent Free gas log sets not sold as components of the fireplace or stove)	
5 years	1 year	X					Vent Free Burners and Vent Free Log components of HHT manufactured fireplaces or stoves	
			X	X			Castings, Medallions and Baffles	
6 years	3 years			X			Catalysts	
7 years	3 years		X	X			Manifold tubes, HHT Chimney and Terminations	
10 years	1 year	X					Burners, logs and refractory components of HHT manufactured fireplaces or stoves	
Limited Lifetime	3 years	X	X	X			Firebox and heat exchanger, FlexBurn® System (engine, inner cover, access cover and fireback)	
1 Year	None	X	X	X	X	X	All purchased replacement parts	

## **WARRANTY CONDITIONS:**

- Because HHT cannot control the quality of any Products sold by unauthorized sellers, this Warranty only covers Products that are purchased through an HHT authorized dealer or distributor unless otherwise prohibited by law; a list of HHT authorized dealers is available on the HHT branded websites.
- This Warranty is only valid while the applicable Product remains at the site of original installation.
- This Warranty is only valid in the country in which the HHT authorized dealer or distributor that sold the applicable Product is authorized to sell applicable Product.
- Contact your installing distributor or dealer for Warranty service. If the installing dealer or distributor is unable to provide necessary parts, contact the nearest HHT authorized dealer or supplier. Additional service fees may apply if you are seeking Warranty service from a dealer other than the dealer from whom you originally purchased the applicable Product.
- No HHT consumer should bear cost of warranty service or costs incurred while servicing warranty claims (i.e., travel, gas, or mileage) when the service is performed within the terms of this Warranty. Check with your dealer or distributor in advance for any costs to you when arranging a warranty call. Travel and shipping charges for parts are not covered by this Warranty.

## **WARRANTY EXCLUSIONS:**

This Warranty does not cover the following:

- Changes in surface finishes as a result of normal use. As a heating appliance, some changes in color of interior and exterior surface finishes may occur. This is not a flaw and is not covered under the Warranty.
- Damage to printed, plated, or enameled surfaces caused by fingerprints, accidents, misuse, scratches, melted items or other external sources and residues left on the plated surfaces from the use of abrasive cleaners or polishes.
- Repair or replacement of parts that are subject to normal wear and tear during the Warranty Period are not covered. These parts include: paint, wood and pellet gaskets, firebricks, grates, flame guides, batteries and the discoloration of glass.
- Minor expansion, contraction, or movement of certain parts causing noise. These conditions are normal and complaints related to this noise are not covered by this Warranty.
- Damages resulting from: (1) failure to install, operate, or maintain the applicable Product in accordance with the installation instructions, operating instructions, and listing agent identification label furnished with the applicable Product; (2) failure to install the applicable Product in accordance with local building codes; (3) shipping or improper handling; (4) improper operation, abuse, misuse, continued operation with damaged, corroded or failed components, accident, or improperly/incorrectly performed repairs; (5) environmental conditions, inadequate ventilation, negative pressure, or drafting caused by tightly sealed constructions, insufficient make-up air supply, or handling devices such as exhaust fans or forced air furnaces or other such causes; (6) use of fuels other than those specified in the operation instructions; (7) installation or use of components not supplied with the applicable Product or any other components not expressly authorized and approved by HHT; (8) modification of the appliance not expressly authorized and approved by HHT in writing; and/or (9) interruptions or fluctuations of electrical power supply to the applicable Product.
- Non-HHT venting components, hearth connections or other accessories used in conjunction with the applicable Product.
- Any part of a pre-existing fireplace system in which an insert or a decorative gas applicable Product is installed.
- HHT's obligation under this Warranty does not extend to the Product's capability to heat the desired space. Information is provided to assist the consumer and the dealer in selecting the proper Product for the application. Consideration must be given to the Product location and configuration, environmental conditions, insulation and air tightness of the structure.

### **This warranty is void if:**

- The applicable Product has been over-fired, operated in atmospheres contaminated by chlorine, fluorine, or other damaging chemicals. Over-firing can be identified by, but not limited to, warped plates or tubes, deformation/warping of interior cast iron structure or components, rust colored cast iron, bubbling, cracking and discoloration of steel or enamel finishes.
- The applicable Product is subjected to prolonged periods of dampness or condensation.
- There is any damage to the applicable Product due to water or weather damage which is the result of, but not limited to, improper chimney or venting installation.

## **LIMITATIONS OF REMEDIES AND LIABILITY:**

- **EXCEPT TO THE EXTENT PROVIDED BY LAW, HHT MAKES NO EXPRESS WARRANTIES OTHER THAN THE WARRANTY SPECIFIED HEREIN. The owner's exclusive remedy and HHT's sole obligation under this Warranty or in contract, tort or otherwise, shall be limited to replacement of the Component Part(s), repair of the Component Part(s), or refund of the original purchase price of the applicable Product(s), as specified above; provided, however, that (i) if HHT is unable to provide replacement of the Component Part(s) and repair of the Component Part(s) is not commercially practicable or cannot be timely made, or (ii) the customer is willing to accept a refund of the purchase price of the applicable Product(s), HHT may discharge all such obligations by refunding the purchase price of the applicable Product. In no event will HHT be liable for any incidental or consequential damages caused by defects in the applicable Product. Some States do not allow the exclusion or limitation of incidental or consequential damages, so the above limitation or exclusion may not apply to you. This Warranty gives you specific legal rights and you may also have other rights which vary from State to State. THE DURATION OF ANY IMPLIED WARRANTY IS LIMITED TO DURATION OF THE EXPRESSED WARRANTY SPECIFIED ABOVE FOR THE APPLICABLE PRODUCT. Some States do not allow limitations on how long an implied warranty lasts, so the above limitation may not apply to you.**

## QUICK START GUIDE

\*Before you plug in this appliance, follow these instructions\*

### Set Up

1. Empty fire box of component packet and any other debris.

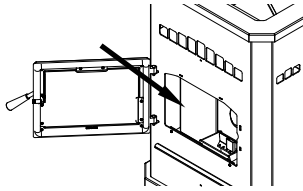

2. Add pellets and close lid.

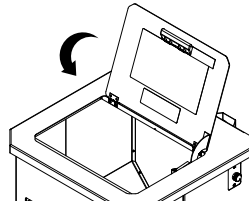

3. Turn DIAL to OFF

4. Plug in the appliance

- Green light will start flashing

5. Ensure thermostat is connected properly per included instructions.

### Prime

1. Quickly turn the dial from OFF to HI two times:

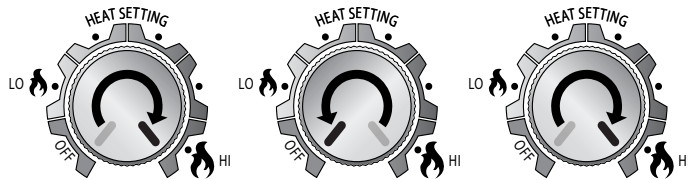

- The LIGHT will turn solid green and pellets will feed. Wait for 2 minutes
- If the LIGHT did not turn solid green:
  - Turn dial back to OFF
  - Unplug appliance, plug it back in and repeat

*Priming is only needed for first fire or starting fire on empty hopper.*

**NOTE:** The prime function is only required during initial set up of the unit, or after the unit has alarmed out due to an empty hopper. Priming while under normal operating conditions will cause the fire pot to overfill.

### Run

1. While thermostat is in RUN mode, the set temperature can be temporarily changed by pressing UP.

2. Choose Setting:

- LO – HI\*
- Green LIGHT will begin flashing and stove will start

\*\*Appliance will not turn on unless target temperature is a higher temperature than the room temperature.

It may take as long as 10 minutes to achieve a fire in the fire pot. Turning the knob or thermostat to off during this time will interrupt the startup process.

\*For first fire, HHT recommends running on HI for first 30 minutes

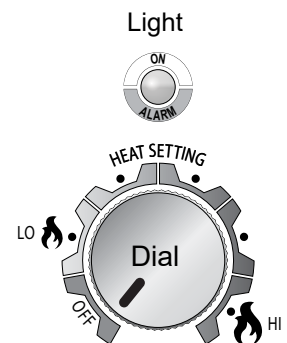

**QUADRA-FIRE**



Trim Control Panel

# 1 Important Safety Information

## A. Appliance Certification

<b>Model</b>	Outfitter-II
<b>Laboratory</b>	OMNI Test Laboratories, Inc.
<b>Report No.</b>	0135PS041E, 061-S-88-8.3
<b>Type</b>	Solid Fuel Room Appliance/Pellet Fuel Burning Type
<b>Standard</b>	ASTM E1509 and ULC S627 Room Appliance Pellet Fuel Burning type and (UM) 84-HUD, Mobile Home Approved.

## B. Appliance Emissions Certification

<b>Model</b>	Outfitter-II
<b>Laboratory</b>	OMNI Test Laboratories, Inc.
<b>Report No.</b>	0135PS041E
<b>Standard</b>	ASTM E2779 and ASTM E2515
<b>Can be found at:</b> <a href="http://www.quadrafire.com/about-us/epa-certification">www.quadrafire.com/about-us/epa-certification</a>	

The OUTFITTER-II is Certified to comply with 2020 particulate emission standards.



This pellet appliance needs periodic inspection and repair for proper operation. Consult the owner's manual for further information. It is against federal regulations to operate this pellet appliance in a manner inconsistent with operating instructions in this manual.

**NOTICE:** This installation must conform with local codes. In the absence of local codes you must comply with the **ASTM E1509, ULC S627 and (UM) 84-HUD.**

## C. BTU & Efficiency Specifications

<b>EPA Certification Number:</b>	128-18
<b>EPA Certified Emissions:</b>	0.53 grams per hour
<b>*LHV Tested Efficiency:</b>	87.5%
<b>**HHV Tested Efficiency:</b>	81.9%
<b>***EPA BTU Output:</b>	9,605 to 40,667 per hr
<b>****BTU Input:</b>	11,676 to 49,207 per hr
<b>Vent Size:</b>	3" or 4" Type "L" or "PL"
<b>Hopper Capacity:</b>	130 lbs.
<b>Fuel</b>	Premium Wood Pellets
* Weighted average LHV (Low Heating Value) efficiency using data collected during EPA emissions tests in accordance with the requirements of CSA B415.1.	
** Weighted average HHV (High Heating Value) efficiency using data collected during EPA emissions tests in accordance with the requirements of CSA B415.1.	
*** A range of BTU outputs calculated using HHV efficiency and the burn rates from the EPA tests.	
**** Based on the maximum feed rate per hour multiplied by approximately 8600 BTU's which is the average BTU's from a pound of pellets.	

## D. Glass Specifications

This appliance is equipped with 5mm ceramic glass. Replace glass only with 5mm ceramic glass. Please contact your dealer for replacement glass.

## E. Electrical Rating (on high)

120 VAC, 60 Hz, Start 2.6 Amps, Run 2.3 Amps

## F. Mobile Home Approved

- This appliance is approved for mobile home installations when not installed in a sleeping room and when an outside combustion air inlet is provided.
- The structural integrity of the mobile home floor, ceiling, and walls must be maintained.
- The appliance must be properly grounded to the frame of the mobile home with #8 copper ground wire, and use only listed double-wall connector pipe.
- Outside Air Kit, part 811-0872 or OAK-3 must be installed in a mobile home installation.
- Appliance must be secured to mobile home structure.

## G. Sleeping Room

When installed in a sleeping room it is recommended that 3ft of vertical be installed prior to horizontally exiting the room and a smoke/CO alarm be installed in the bedroom; The size of the room must be at least 50ft<sup>3</sup> per 1,000 Btu/hr stove input, if the stove exceeds the room size, outside air must be installed.

## H. California - Prop65

### WARNING

This product and the fuels used to operate this product (wood), and the products of combustion of such fuels, can expose you to chemicals including carbon black, which is known to the State of California to cause cancer, and carbon monoxide, which is known to the State of California to cause birth defects or other reproductive harm. For more information go to: [WWW.P65Warnings.ca.gov](http://WWW.P65Warnings.ca.gov)



### WARNING



#### Fire Risk

Hearth & Home Technologies disclaims any responsibility for, and the warranty will be voided by, the following actions:

- Installation and use of any damaged appliance.
  - Modification of the appliance.
  - Installation other than as instructed by Hearth & Home Technologies.
  - Installation and/or use of any component part not approved by Hearth & Home Technologies.
  - Operating appliance without fully assembling all components.
  - Operating appliance without legs attached (if supplied with appliance).
  - Do NOT Over fire - If appliance or chimney connector glows, you are over firing.
- Any such action that may cause a fire hazard.

Improper installation, adjustment, alteration, service or maintenance can cause injury or property damage.

For assistance or additional information, consult a qualified installer, service agency or your dealer.

**NOTE:** Hearth & Home Technologies, manufacturer of this appliance, reserves the right to alter its products, their specifications and/or price without notice.

Hearth & Home Technologies WILL NOT warranty appliances that exhibit evidence of over-firing. Evidence of over-firing includes, but is not limited to:

- Warped air tube
- Deteriorated refractory brick retainers
- Deteriorated baffle and other interior components



## 2 General Information

### A. Fire Safety

To provide reasonable fire safety, the following should be given serious consideration:

- Install at least one smoke detector on each floor of your home.
- Install at least one carbon monoxide detector on each floor of your home.
- Locate smoke detector away from the heating appliance and close to the sleeping areas.
- Follow the smoke detector manufacturer's placement and installation instructions and maintain regularly.
- Follow the carbon monoxide manufacturer's placement and installation instructions and maintain regularly.
- Conveniently locate a Class A fire extinguisher to contend with small fires.
- In the event of a hopper fire:
  - Evacuate the house immediately.
  - Notify fire department.

### B. Combustible/Non-Combustible Materials

- **Combustible Material**
  - Material made of or surfaced with wood, compressed paper, plant fibers, plastics, or any material capable of igniting and burning, whether flame-proofed or not, plastered or non plastered.
- **Non-combustible Material**
  - Material which will not ignite and burn. Such materials are those consisting entirely of steel, iron, brick, tile, slate, glass or plasters, or any combination thereof.
- **Non-combustible Sealant Material**
  - Sealants which will not ignite and burn: Rutland, Inc. Fireplace Mortar #63, Rutland 76R, Nuflex 304, GE RTV106 or GE RTB116 (or equivalent).

### C. Fuel Material and Fuel Storage

Pellet fuel quality can greatly fluctuate. We recommend that you buy fuel in multi-ton lots whenever possible. However, we do recommend trying various brands before purchasing multi-ton lots to ensure your satisfaction.

#### Fuel Material

- Made from sawdust or wood by-products
- Depending on the source material it may have a high or low ash content.

#### Higher Ash Content Material

- Hardwoods with a high mineral content
- Fuel that contains bark
- Standard grade pellets or high ash pellets

#### Lower Ash Content Material

- Most softwoods
- Fuels with low mineral content
- Most premium grade pellets

### Clinkers

Minerals and other non-combustible materials such as sand will turn into a hard, glass-like substance called a clinker when heated in the firepot.

Trees from different areas will vary in mineral content. That is why some fuels produce more clinkers than others.

### Moisture

Always burn dry fuel. Burning fuel with high moisture content takes heat from the fuel and tends to cool the appliance, robbing heat from your home. Damp pellet fuel can clog the feed system.

### Size

- Pellets are either 1/4 inch or 5/16 inch (6-8mm) in diameter
- Length should be no more than 1-1/2 inches (38mm)
- Pellet lengths can vary from lot to lot from the same manufacturer
- Due to length variations, the feed rate may need adjusting occasionally

### Performance

- Higher ash content requires the firepot and the ash drawer to be emptied more frequently
- Hardwoods require more air to burn properly
- Premium wood pellets produce the highest heat output
- Burning pellets longer than 1-1/2 inches (38mm) can cause an inconsistent fuel feed rate and/or missed ignitions of feed jams.

### Storage

- Wood pellets should be left in their original sealed bag until using to prevent moisture absorption
- Do not store any pellet fuel within the clearance requirements or in an area that would hinder routine cleaning and maintenance.

### D. Before Your First Fire

1. First, make sure your appliance has been properly installed and that all safety requirements have been met. Pay particular attention to the fire protection and venting.
2. Double check that the firebox is empty and the firepot is in place!
3. Close and latch the door.

# 3 General Operating Information

## WARNING



### HOT SURFACES!

Glass and other surfaces are hot during operation AND cool down.

**Hot glass will cause burns.**

- Do not touch glass until it is cooled
- NEVER allow children to touch glass
- Keep children away
- CAREFULLY SUPERVISE children in same room as appliance.
- Alert children and adults to hazards of high temperatures.
- **High temperatures may ignite clothing or other flammable materials.**
- Keep clothing, furniture, draperies and other flammable materials away.

**NOTICE:** If you expect that children may come into contact with this appliance, we recommend a barrier such as a decorative screen (See your retailer for suggestions).

## A. General Operating Parts

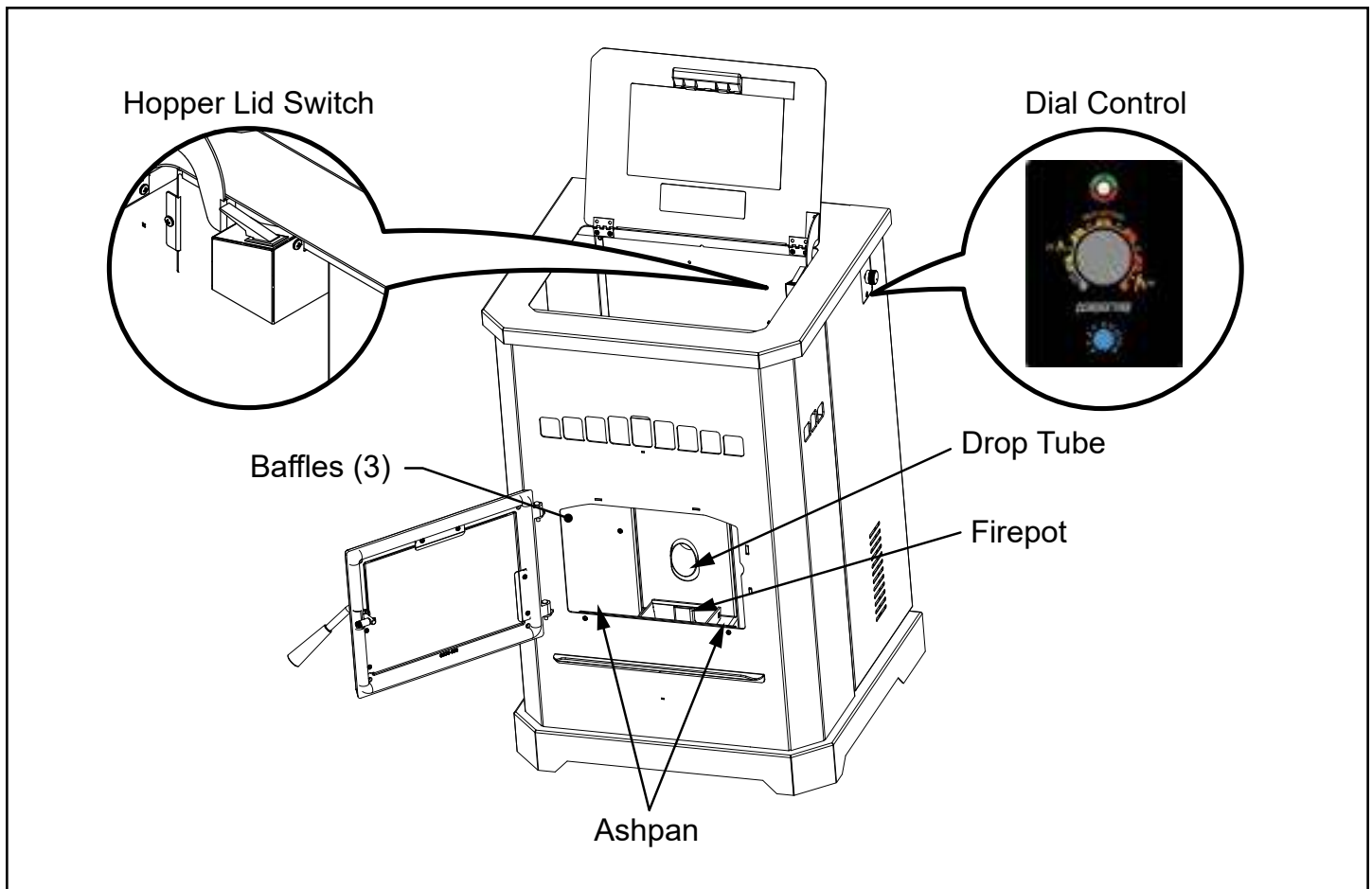

## B. Priming the Feed Tube



### STOP!

Please Read Prior to Attempting Prime Function

When attempting Prime function it is NECESSARY to operate the dial control QUICKLY in a single fluid motion. If this is not performed properly, the appliance will not prime.



### WARNING

A FIREPOT THAT IS MORE THAN HALF FULL IS OVERFILLED AND CAN BE DANGEROUS. DO NOT OVERFILL FIREPOT FOR IGNITION.

Overfilling the firepot could cause an unsafe ignition resulting in injury or damage. Firepot must be emptied.

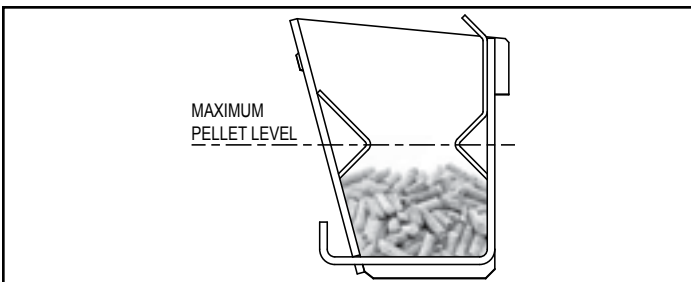

The feed tube may need to be primed only if the hopper is being filled for the first time or if the appliance has run out of pellets. To prime the appliance, turn the dial control QUICKLY from the OFF position to the HI position, to OFF to HI in one fluid motion. The LED light will be a solid green color to indicate a successful prime function. When the feed motor is running continuously, the LED light will be a solid green color. When pellets start to drop into the firepot, the feed tube is primed. Turn the dial control to the desired position and the appliance will begin its ignition sequence with a blinking green light. Allow the appliance up to 20 minutes for ignition to occur.



### CAUTION

Do not restart or manually add pellets or any type of fuel to the burn pot during this process.

If the appliance does not ignite, the LED light will blink red four times showing a missed ignition alarm. Turn the appliance to off and remove and EMPTY the firepot.

Return the firepot to the appliance in the correct orientation. See figure in Cleaning Fire pot in the General Maintenance section of Owner's Manual under Maintaining and Servicing the Appliance.

Attempt relighting sequence (see Lighting Instructions Guide).

## C. Firepot Burn Down

A feature of these pellet appliances is the firepot burn down cycle. The frequency of the cycle is once every hour the appliance is burning. During this event, the feed is reduced to the lowest setting and the exhaust blower ramps up to the highest setting. The purpose of the burn down cycle is to help remove debris from the firepot and help the appliance burn as efficient as possible. The cycle lasts 99 seconds. Please be aware that the burn down does not replace daily cleaning activities but makes them easier.

## D. Shutdown

To shut the appliance down, turn the dial control counter clockwise to the OFF position. During the shutdown process, the LED will flash amber or green rapidly just like the ignition sequence. The firepot burn down cycle will begin but without the feed motor running. The feed will be terminated during this shutdown process. The exhaust and convection blowers will remain on during the shutdown process until the exhaust has cooled.

If maintenance or daily cleaning is going to be conducted immediately following a shutdown, please use caution as components especially those inside the firebox may still be hot.

**Please note that if the dial control is turned to the off position and back on even if by mistake, the appliance will go through the shutdown sequence.**

## E. Starting Your First Fire

1. Turn the dial control to "OFF".
2. Make sure the firepot is clean, in place, and free of debris.
3. Plug the appliance into the wall and fill the hopper with wood pellets. Shut the hopper lid.
4. Turn the dial control to the desired burn setting.

The appliance will go into the ignition sequence followed by start up (The green LED will flash rapidly). The ignition sequence involves the exhaust blower turning on, the igniter turning on, and the feed motor running in two stages. The first stage involves the feed motor running continuously for about a minute to preload pellets into the firepot. Following the preload and a delay, the feed motor will begin cycling on and off. When the pellets are warming up and on the verge of igniting, it is not uncommon for the firebox to fill with smoke. Once ignition actually happens, the smoke should evacuate quickly. During this stage as well as any part during the burn process, the front door should not be opened. This cycle continues until the appliance senses ignition by a rise in the exhaust temperature or the appliance times out. Following the ignition cycle the appliance begins to feed additional pellets gradually for a few minutes to build up the fire. This is important to have a controlled start up to keep the appliance in balance.

## F. Fire Characteristics

The overall height of the flame will vary throughout the burn for a couple of reasons. First is that the flame will vary based on type of fuel or even batch of fuel. Secondly, the appliance adjusts the burn rate according to the how far away the room temperature is from the set temperature. This should not cause alarm. The third characteristic that affects the fire relates to general maintenance and cleaning. Infrequent or poor general maintenance will result in poorer performance. Indicators of the need for additional maintenance activities include a lazy flame, black sooted glass, pellets not igniting, or pellets falling to the side of the firepot. See the maintenance section for additional information.

 <b>CAUTION</b>
Odors, vapors, and smoke released during initial operation.
<ul style="list-style-type: none"> <li>• Curing of high temperature paint.</li> <li>• Open windows for air circulation.</li> </ul>
Odors may be irritating to sensitive individuals.

## G. Ignition Cycles

1. At the beginning of each ignition cycle, it is normal to see some smoke in the firebox. The smoke will stop once the fire starts.
2. The convection blower will automatically turn on after your appliance has reached a sufficient temperature.
3. This blower transfers heat from your appliance into the room, and will continue to run even after the appliance has shutdown. It will turn off after the exhaust temperature has cooled.
4. Occasionally the appliance may run out of fuel and shut itself down. When this happens the empty hopper alarm will be triggered.

## H. Trim Adjustment

**Trim adjustment** is the small dial located below the main dial control. The function of the trim adjustment is to allow for variations in elevation, venting and installation configurations, and fuel types (hard wood/soft wood).

Rotating this dial will adjust the air/fuel ratio to the appliance:

- Clockwise adjustments increase the flame height.
- Counter-clockwise adjustments will decrease the flame height.
- When changing trim settings only adjust 1 level at a time, allowing 15 minutes for fire to stabilize before making another adjustment.
- The factory default trim adjustments are set to zero (0) for most fuels and recommended venting configurations.

A properly adjusted fire will have a bright, active flame pattern that extends out of the fire pot approximately 6 to 9 inches when burning on high. A properly adjusted fire will burn cleaner and have higher efficiencies.

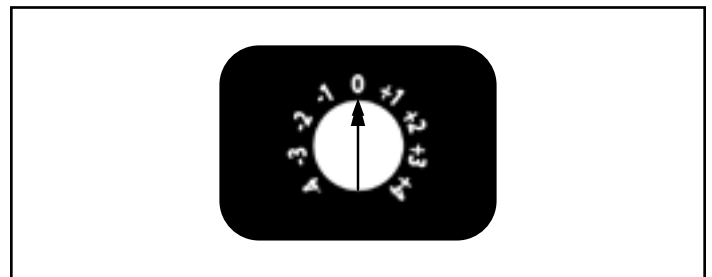



Figure 12.1

## I. Clear Space

 <b>WARNING</b>
<b>RISK OF FIRE!</b>
Do NOT place combustible objects in front or to the sides of the appliance. High temperatures may ignite clothing, furniture or draperies.

**Mantel:** Avoid placing candles and other heat-sensitive objects on mantel or hearth. Heat may damage these objects.

<b>NOTICE:</b> Clearances may only be reduced by means approved by the regulatory authority having jurisdiction.
--

 <b>WARNING</b>
<b>RISK OF FIRE!</b>
Keep combustible materials, gasoline and other flammable vapors and liquids clear of appliance.
<ul style="list-style-type: none"> <li>• Do NOT store flammable materials in the appliance's vicinity.</li> <li>• Do NOT use gasoline, lantern fuel, kerosene, charcoal lighter fluid or similar liquids to start or "freshen up" a fire in this heater.</li> </ul>
Keep all such liquids well away from the heater while it is in use as combustible materials may ignite.

## J. Thermostat Controls

Reference instruction sheet supplied with thermostat

### STATIC NOTICE

Thermostat is protected against normal static electric discharges, however to minimize the risk of damaging the thermostat in extremely dry weather, please touch a grounded metal object before touching the thermostat.

### CONNECT THERMOSTAT WIRES TO APPLIANCE:

There is a 4 screw terminal block located on the back lower left corner of the stove directly above the power cord inlet. The center 2 screws are for the thermostat wires (**Figure 13.1**).

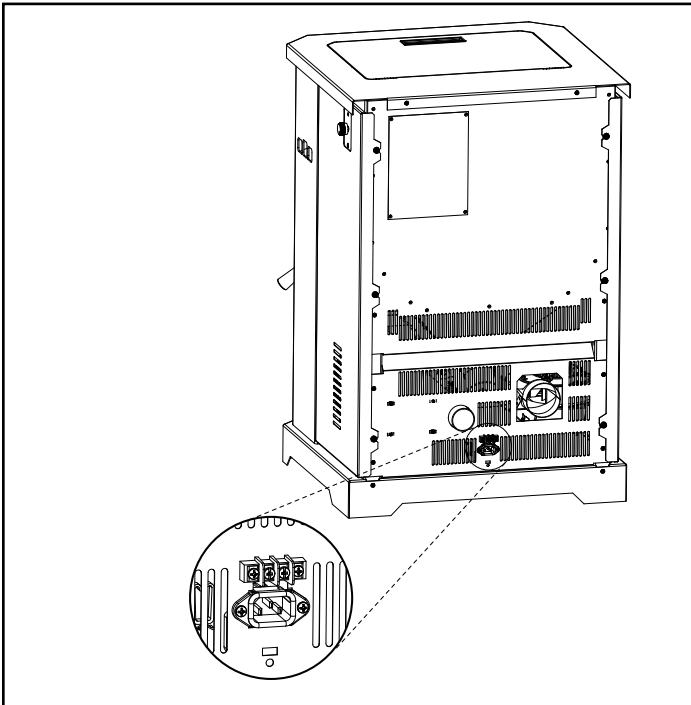

Figure 13.1



### CAUTION



Shock hazard.

- Do NOT remove grounding prong from plug.
- Plug directly into properly grounded 3 prong receptacle.
- Route cord away from appliance.
- Do NOT route cord under or in front of appliance.

## K. LED Color Coding Chart and Explanation

LED Color	Number of Flashes between pauses	Description	Notes
Green	Steady ON while priming feed tube (max time 2 minutes)	Feed Motor is running continuously. (This primes the feed tube).	When priming the feed system and filling the firepot, <b>DO NOT OVERFILL FIREPOT FOR IGNITION</b> . The appliance will automatically go into start up following the prime function.
Green	1x	Appliance is off and ready.	To start appliance, follow start up sequence.
Green	Blinks Continuously	Appliance is in the start up/ignition sequence or in shutdown.	During shut down, the blowers will shut off when the exhaust temperature has cooled.
Green	Varies	When in the automatic mode, the number of flashes between pauses indicates the burn rate (1 for low up to 5 for high).	Adjust the dial control to change the desired room temperature.
Amber	Blinks Continuously	Appliance is in the in shutdown sequence.	During shut down, the blowers will shut off when the exhaust temperature has cooled.
Red	1x	Empty Hopper Alarm	This alarm is caused by the fire going out from lack of fuel.
Red	2x	Exhaust Probe Alarm	Failed component error. See troubleshooting section for more information.
Red	4x	Missed Ignition	There are a total of 2 tries per ignition sequence. If after 2 tries there is no rise in exhaust temperature this error will occur. See the troubleshooting section for additional information and correction.
Red	8x	Exhaust Gas Over Temperature Alarm	The exhaust temperature exceeds the allowable limit. See the troubleshooting section for more information and correction.



### WARNING



#### Fire Risk

Do NOT operate appliance:

- With appliance door open.
- Firepot floor open.

Do NOT store fuel:

- Closer than required clearances to combustibles to appliance
- Within space required for loading or ash removal.

# 4 Maintaining & Servicing Your Appliance

When properly maintained, your appliance will give you many years of trouble-free service. Contact your dealer to answer questions regarding proper operation, troubleshooting and service for your appliance.

## A. Proper Shutdown Procedure

Turn dial control to off, let appliance completely cool and exhaust blower must be off. After cooling unplug appliance before servicing.

**Follow the detailed instructions found in this section for each step listed as referenced in the chart below.**

## B. Quick Reference Maintenance Chart

Cleaning or Inspection	Frequency		Daily	Weekly	Monthly	Yearly
Firepot	Every 3 bags of fuel	OR	X			
Ash Removal from Firebox	Every 5 bags of fuel or more frequently depending on ash build-up	OR		X		
Glass	When clear view of firepot becomes obscure	OR		X		
Hopper	Every 25 bags of fuel	OR			X	
Exhaust Path, Drop Tube and Behind Baffles	Every 25 bags or more frequently depending on ash build-up	OR			X	
Door Handle & Gasket Inspection	Prior to heating season	OR			X	
Blower, Convection	Every 25 bags or more frequently depending on operating environment.	OR			X	
Blower, Exhaust	More frequently depending on the fuel type	OR				X
Firebox - Prepare for Non-Burn Season	At end of heating season	OR				X
Venting System	Every 3 tons or more frequently depending on the fuel type	OR				X

**CAUTION**



**Shock and Smoke Hazard**

- Smoke spillage into room can occur if appliance is not cool before unplugging.
- Risk of shock if appliance not unplugged before servicing appliance.

**NOTICE:** These are recommendations. Clean more frequently if you encounter heavy build-up of ash at the recommended interval or you see soot coming from the vent. **Not properly cleaning your appliance on a regular basis will void your warranty.**

## C. General Maintenance

### 1. Types of Fuel

The type of fuel you are burning will dictate how often you have to clean your firepot.

If the fuel you are burning has a high dirt or ash content, it may be necessary to clean the firepot more than once a day.

Poor quality fuel will cause clinkers to form in the firepot. A clinker is formed when dirt, ash or a non-burnable substance is heated to 2000°F (1093°C) and becomes glass-like. See section D following for more details on fuels with high ash content.

### 2. Cleaning Firepot with the Firepot Clean-Out Tool

- **Frequency:** Daily or more often as needed
- **By:** Homeowner
  - a. The appliance must be in complete shutdown and cool and the exhaust blower off. If you are just cleaning the firepot, there is no need to unplug the appliance.
  - b. Open the front door of the appliance and lift out the firepot. Use the firepot cleaning tool to break up deposits inside the firepot and dispose in an approved container. Depending on the quality of fuel used, the front of the firepot may need to be removed for better access for cleaning.
  - c. Use the narrow end of the firepot cleaning tool to clean the holes.
  - d. With the firepot out clean the area below the firepot.
  - e. Reassemble the firepot and place back inside the firepot riser. Make sure the firepot is in the correct direction with the slanted lip in the rear. Failure to install the firepot correctly may result in missed ignitions.

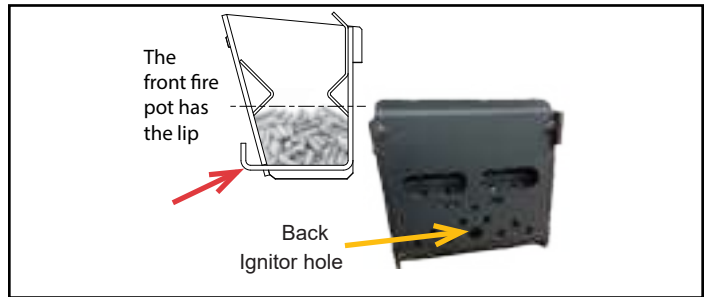
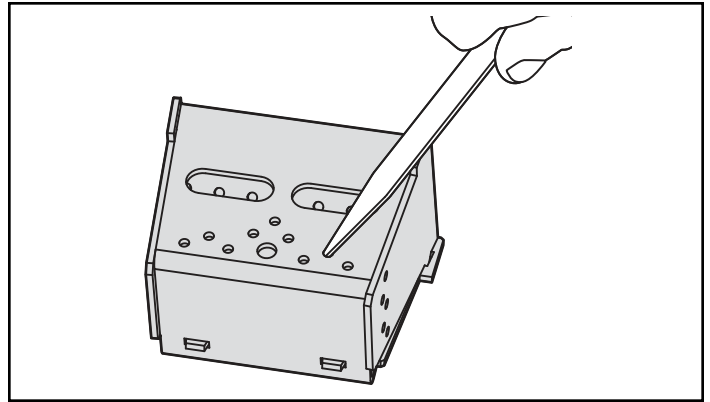
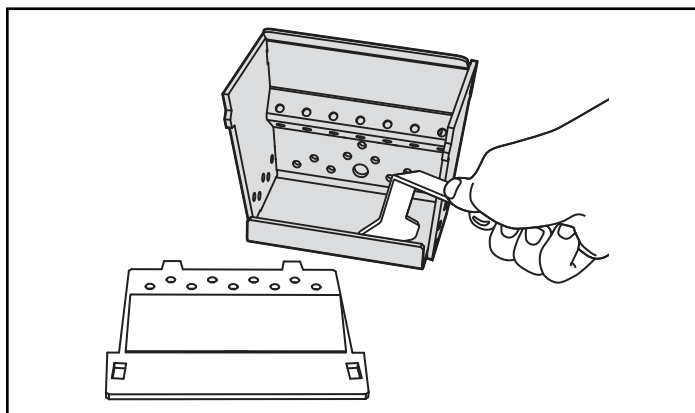

### 3. Ash Removal from Firebox

- **Frequency:** Weekly or more frequently depending on ash build-up.
- **By:** Homeowner
  - a. There must not be any hot ashes in the firebox during cleaning so allow the appliance to completely cool. The firebox ash should be removed every time the exhaust path is cleaned. Frequent cleaning of the ash in the firebox will help slow down the build-up of ash in the exhaust blower and vent system.
  - b. Vacuum out the firebox thoroughly on both sides of the firebox and the floor and ceiling. Remember to place the ash and debris into a metal or non-combustible container.

**See Disposal of Ashes.**





#### 4. Disposal of Ashes

- **Frequency:** As needed
- **By:** Homeowner

Ashes should be placed in a metal container with a tight-fitting lid. The closed container of ashes should be placed on a non-combustible floor or on the ground, well away from all combustible materials, pending final disposal.

If the ashes are disposed of by burial in soil or otherwise locally dispersed, they should be retained in the closed container until all cinders have been thoroughly cooled.

 <b>WARNING</b>	
	<b>Disposal of Ashes</b>
	<ul style="list-style-type: none"><li>• Ashes should be placed in metal container with tight fitting lid.</li><li>• Ashes should be retained in closed container until all cinders have thoroughly cooled.</li></ul>

#### 5. Cleaning the Glass

- **Frequency:** When clear view of the firepot becomes obscure
- **By:** Homeowner
  - a. Appliance must be completely cool before cleaning glass.
  - b. Vacuum fly ash from glass and door rope.
  - c. Use a damp paper towel or any non-abrasive glass cleaner. Wipe off with dry towel.

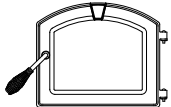
 <b>CAUTION</b>	
	Handle glass assembly with care.
	<b>When cleaning glass:</b> <ul style="list-style-type: none"><li>• Avoid striking, scratching or slamming glass.</li></ul>
<ul style="list-style-type: none"><li>• Do NOT clean glass when hot.</li><li>• Do NOT use abrasive cleaners.</li><li>• Refer to maintenance instructions.</li><li>• Do NOT operate with glass cracked, broken or scratched.</li></ul>	

#### 6. Cleaning the Hopper

- **Frequency:** Monthly or after burning 25 bags of fuel
- **By:** Homeowner

After burning approximately 25 bags of fuel you will need to clean the hopper to prevent sawdust build-up.

A combination of sawdust and pellets on the bottom end of the auger reduces the amount of fuel supply to the firepot. This can result in nuisance shutdowns and mis-starts.

- a. The appliance must be in complete shutdown. Allow the appliance to completely run out of pellets and cool down.
- b. Empty the hopper of any remaining pellets.
- c. Vacuum the hopper and feed tube. To access the feed tube remove the four screws from the auger cover located inside of the hopper.



## 7. Cleaning the Exhaust Path, Baffles & Drop Tube

- **Frequency:** Monthly or every 25 bags or more frequently depending on ash build-up.
- **By:** Homeowner
  - a. Appliance must be completely cool.
  - b. Open the door and remove the center baffle first and then the right and left baffles. Thoroughly vacuum the exhaust path and drop tube and continue throughout the rest of the firebox. Also vacuum the front and back of the baffles.
  - c. Using a small brush, clean the inner walls of the exhaust outlet from the access hole inside the firebox. The access hole will be visible following the removal of the left side baffle. After loosening up debris on the inner walls of the outlet, vacuum out.
    - This is important as the exhaust temperature probe is attached to the right side of the outlet. If this is not maintained on a regular basis, the appliance will experience nuisance shut downs and/or missed ignitions.
  - d. Replace the right and left baffles and then the center baffle and close and latch the door.
  - e. Clean ash from ashpans by using a vacuum or by simply removing the ash pans located on the left and right hand side and disposing the ashes into a metal container.

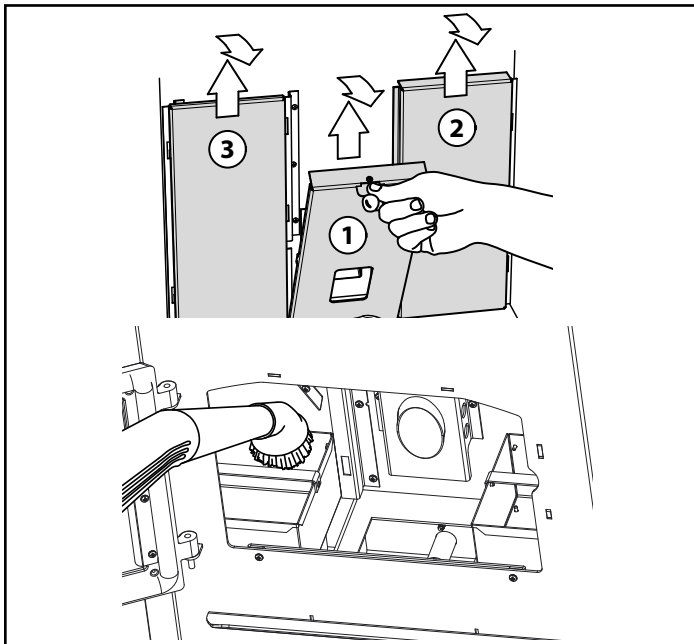

## 8. Door Handle Inspection

- **Frequency:** Monthly or prior to heating season
  - **By:** Homeowner
- The gasket between the glass and firebox should be inspected periodically to make sure there is a good seal.

**NOTE:** Quadra-Fire recommends using a heavy duty vacuum cleaner specifically designed for solid fuel appliance cleaning.

## 9. Cleaning Convection Blower - Requires No Lubrication

- **Frequency:** Monthly depending on Dust/Dirt build-up
- **By:** Homeowner or Qualified Service Technician

- a. Be sure the appliance is allowed to cool and has been unplugged.
- b. Remove the right side panel.
- c. Using a 3/8 socket or wrench, remove convection blower bolts and bracket.
- d. Sweep or vacuum out any build-up on the impellers. Use a brush or compressed air to loosen dirt if needed.
  - Avoid damaging the impellers.

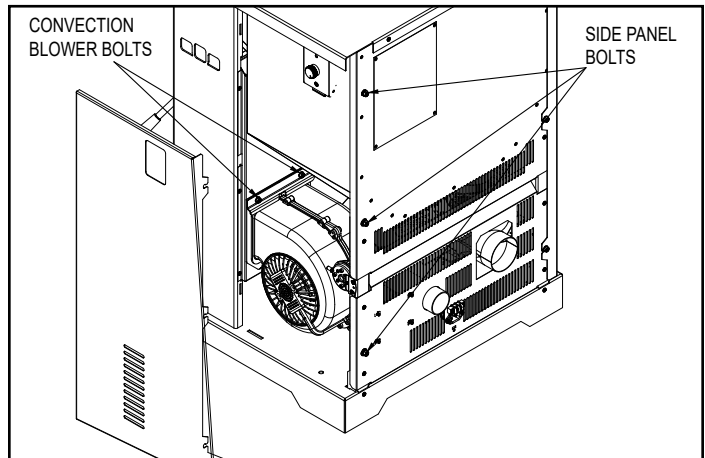

## 10. Cleaning Exhaust Blower - Requires No Lubrication

- **Frequency:** Yearly or more frequently depending on ash build-up
- **By:** Homeowner or Qualified Service Technician
  - a. Be sure the appliance is allowed to cool, has been unplugged and the exhaust blower is off.
  - b. Remove the left side panel.
  - c. Remove the six screws holding the exhaust blower motor to the housing and remove the motor. Using caution as to not damage the gasket when removing the blower. If damage occurs, install a new gasket available as a replacement part.
  - d. Vacuum the blower's impellers. Use care not to bend or damage the blower fins.
  - e. Using a brush or vacuum attachment, clean the inside of the exhaust outlet.
  - f. Reattach the motor. Make sure the wires are attached to the terminals on the blower.

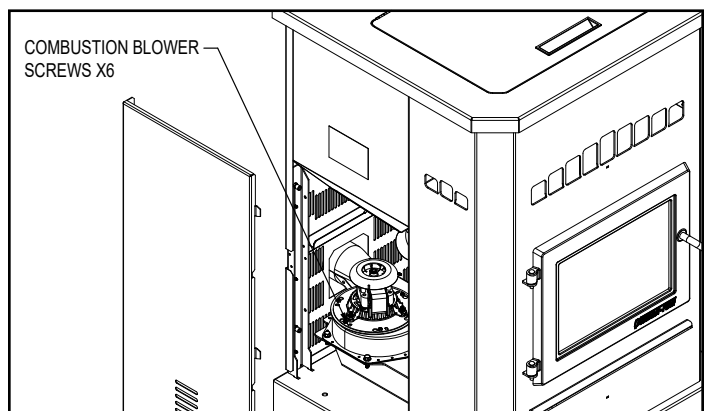

## 11. Preparing Firebox for Non-Burn Season

- **Frequency:** Yearly
- **By:** Homeowner
  - a. Be sure the appliance is allowed to cool, has been unplugged and the exhaust blower is off.
  - b. Remove all ash from the firebox and vacuum thoroughly.
  - c. Paint all exposed steel, including cast-iron.
    - Purchase high temperature paint from your local retailer.
    - Must use a high-temperature paint made specifically for heating appliances.

## 12. Soot and Fly Ash: Formation & Need for Removal in Exhaust Venting System.

- **Frequency:** Yearly or more frequently depending on ash build-up.
- **By:** Qualified Service Technician/Homeowner

Be sure the appliance is allowed to cool, has been unplugged and the exhaust blower is off.

The products of combustion will contain small particles of fly ash. The fly ash will collect in the exhaust venting system and restrict the flow of the flue gases.

At start-up if there is incomplete combustion, or if there is a shutdown or incorrect operation of the appliance it will lead to some soot formation. This will collect in the exhaust venting system.

The venting (chimney) system may need to be cleaned at least once a year or more often depending upon the quality of your fuel or if there are any horizontal pipe sections. Ash will build up more quickly in the horizontal sections and elbows.

## D. High Ash Fuel Content Maintenance

- **Frequency:** As needed
- **By:** Homeowner

Poor quality pellet fuel, lack of maintenance, or if the small dial control is set to a less than optimum setting, poor combustion conditions that make the firepot fill quickly with ashes and clinkers.

This condition makes the appliance susceptible to overfilling the firepot with pellets which may result in smoking, sooting and possible hopper fires. The figure below shows an example where the firepot overfills, pellets back up into the feed tube and ash has accumulated in the firebox.

An inefficient and non-economical method of burning of fuel caused by poor quality pellet fuel is shown below.

If the ash buildup exceeds the half way point in the firepot **IMMEDIATE ATTENTION AND CLEANING IS REQUIRED.**

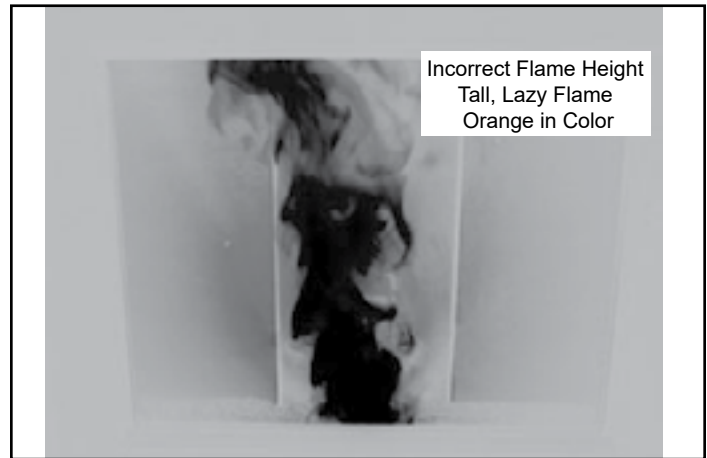
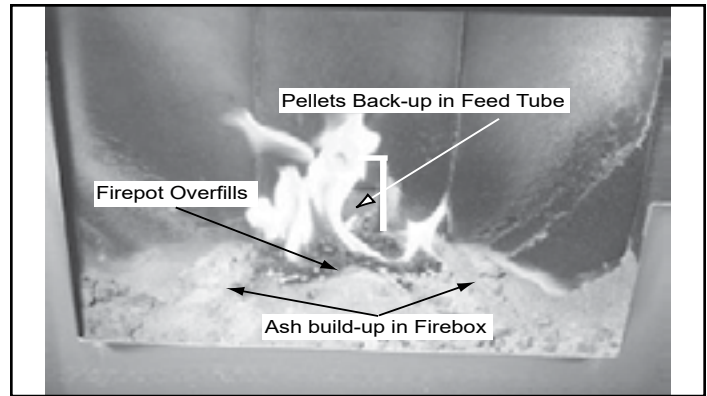

## E. Frequently Asked Questions

### What causes my glass to become dirty?

If the glass has white ash build up it is normal and the glass should be cleaned. If it is a black soot build up airflow through the appliance may be restricted. The most often cause is overdue maintenance and cleaning. See “Maintaining and Servicing Appliance” in the owner’s manual and/or make adjustments to the trim control.

### How can I get more heat out of the appliance?

The most often cause of diminished heat output is overdue maintenance and cleaning. See “Maintaining and Servicing Appliance” in Section 4.

### What should I do if I smell smoke or there is ash/soot coming from the appliance?

While there will always be some smoke smell from wood burning appliances (including pellet) you should investigate all venting to make sure it is sealed properly. Most venting requires silicone to seal the seams. In addition most homes are built very tight today and with exhaust systems can create negative pressure in the home. See “Negative Pressure” under Vent Information in the Installation Manual if you have checked the venting but still have smoke coming from the appliance. For ash or soot check the above and the exhaust blower housing and seals.

### Why would my appliance run fine last winter but not start this fall?

It is possible that the stove was not properly prepared for the Non-burn season.

### Why would the metal on the inside of the appliance begin to flake?

There are some pellet mills that get their raw materials from lumber mills that purchase logs that are transported in sea water. These pellets can have a higher salt content and cause the metals in the appliance to corrode prematurely and deteriorate. If you are seeing any components inside the firebox deteriorate it is recommended to change pellet brands immediately.

### Is there a place to lubricate the blowers to quiet them down?

The most often cause of noisy blowers is from the impellers becoming dirty over time. See “General Maintenance & Cleaning” under “Maintaining & Servicing Appliance” in Section 4. No form of lubrication should ever need to be applied to the blowers.

### What is the metal object with the bend in it for that came inside the plastic bag?

It is a clean-out tool used to help clean the firepot and remove any jams in the rare event they occur in the feed tube.

### Why is there a black residue building up on the outside of my home?

Wind can cause this to happen. If the appliance is operating correctly very little soot should ever exit the termination cap. Also check to be sure the venting is installed per the owner’s manual and local codes.

### Do I need an outside air kit?

Outside air is required for mobile home installations and in some jurisdictions. Refer to “Listing & Code Approvals” and “Mobile Home Installation”. Also refer to local building codes.

### I am seeing sparks coming out of my pipe (termination cap) outside is this safe?

This is normal. As long as clearances to combustibles were followed this is safe.

### I have no power to anything. Does this appliance have a circuit breaker or fuse or a reset button?

This appliance has one serviceable fuse on the control board and a resettable snap switch mounted to the feed tube.



### Can I burn corn in my appliance?

NO, corn is not an approved fuel.

### Where is the serial # of my appliance is located?

The serial # is located on the back of the stove.

## F. Glass Replacement

 <b>WARNING</b>	
	<ul style="list-style-type: none"><li>• Glass is 5mm thick high temperature heat-resistant ceramic glass.</li><li>• DO NOT REPLACE with any other material.</li><li>• Alternate material may shatter and cause injury.</li></ul>
	<ol style="list-style-type: none"><li>1. Open the door from the appliance by lifting door off of hinge pins and lay on a flat surface face down.</li><li>2. Using a Phillips Head screw driver, remove the 3 brackets and set aside.</li><li>3. Remove old glass and replace with the new glass.</li><li>4. Re-install the brackets using the same screws.</li></ol>

# 5 Troubleshooting

With proper installation, operation, and maintenance your appliance will provide years of trouble-free service. If you do experience a problem, this troubleshooting guide will assist a qualified service person in the diagnosis of a problem and the corrective action to be taken. This troubleshooting guide can only be used by a qualified service technician.

Symptom	Possible Cause	Corrective Action	
Plug in appliance - no response	No power to outlet	Check circuit breaker at service panel.	
	5 amp fuse defective or blown	Replace Fuse.	
	Snap disc tripped or defective	Reset or replace snap disc.	
Appliance will not light	No fuel, Out fo Fuel	Check hopper. Fill with fuel.	
	Vacuum switch not closing, no vacuum	Check vacuum switch is plugged in	
		Check vacuum hose is in good condition clear and connected at both ends	
		Make sure venting system is clean	
		Make sure front door is closed	
		Check vacuum switch fitting on side of feed tube for blockage	
	Hopper lid open	Close hopper lid	
	Defective hopper switch	Check hopper switch operation	
	Feed system is jammed	Inspect and un-jam the feed assembly	
	Feed motor not plugged in	reconnect feed motor	
	No igniter	Plug the igniter in	
	Igniter not centered	Center the Igniter	
	Igniter defective	Igniter seated in chamber completely	
		replace igniter	
	Firepot plugged	Clean firepot	
	Firepot dirty	Clean below the firepot	
Firepot in backwards	Put the firepot in the correct direction		
Too much debris in the bottom of the firepot	Clean firepot		
Fire starts but goes out	Firepot is dirty	clean firepot. Check flue vent for obstruction	
	Exhaust path and/or venting is plugged	Inspect and clean exhaust path and venting clean firebox including behind the baffles	
	Exhaust sensor cannot read correct temperature / Exhaust path is dirty	Inspect and clean the exhaust outlet especially the right side wall.	
	Exhaust probe is not attached to outlet	Remove the right side panel and inspect to see if the exhaust probe is attached and tight against the exhaust outlet	
	Exhaust probe is not plugged in to the board	Plug the probe into the board	
	Exhaust probe is defective (error code may result)	Replace the exhaust probe	
Appliance start and stops frequently when operating in the automatic mode	Area where the thermostat is placed affects temperature	Check thermostat proximity to doors and windows	
	Thermostat located in tight spaces effecting the on/off cycling of the appliance	Inspect thermostat location and make sure it is not close to a surface that heats and cools quickly	

Symptom	Possible Cause	Corrective Action
Slow or smoky start-up and/or lazy flame	Dirty fire pot, exhaust path, and/or venting system.	Check for ash build up in appliance, including behind rear panels, firebox, exhaust blower and venting.
	Not enough combustion air	Adjust the trim
	Misaligned igniter Wet fuel / poor quality fuel	Center the igniter in the chamber Replace fuel
Convection blower fails to start.	Convection Blower Jammed Not plugged in	Inspect, clean, and un-jam the blower. Plug the blower in. Replace blower.
	Exhaust probe Not sensing correct temperature	Clean the exhaust outlet especially the right side.
	Control board is defective.	Replace control board.
Exhaust blower fails to start	Exhaust Blower Jammed Not plugged in	Inspect, clean, and un-jam the blower. Plug the blower in Replace blower
	Control board is defective.	Replace control board.
Convection Blower Does Not Turn Off	Screws attaching convection blower to appliance have become loose.	Tighten screws
	Convection blower is dirty	Clean blower impellers
Convection Blower makes noise	Screws attaching convection blower to appliance have become loose.	Tighten screws
	Convection blower is dirty	Clean blower impellers
Exhaust Blower Does Not Turn Off	Exhaust blower short circuit. The fuse will be blown and upon replacement of the fuse, the blower will run continuously.	Inspect wires, blowers, and power cord to find cause of short circuit. Replace board and failed component.
Igniter does not turn off	Igniter short circuit. The fuse will be blown and upon replacement of the fuse, the igniter will remain on when appliance has power.	Inspect wires, blowers, and power cord to find cause of short circuit. Replace board and failed component.
Feed motor does not shut off	Feed motor short circuit. The fuse will be blown and upon replacement of the fuse, the feed motor will remain on when appliance has power.	Open hopper to stop the feed motor. Inspect wires feed motor, control board, and power cord to find source of short circuit. Replace control board and failed component.
Appliance fails to shut off.	Appliance running in maximum or minimum	Turn dial control to Automatic or Off position. See Also, "Feed Motor Does Not Shut Off". The appliance should go into a shutdown.
Large, lazy flame, orange color. Black ash on glass.	Dirty appliance. Poor fuel quality, high ash content.	Clean appliance, including firepot and venting system. Clean exhaust path. Try a different brand of pellets.
	Incorrect air-fuel adjustment	Turn fuel adjustment trim dial to LEFT to increase combustion air speed.
	Excessive feeding/Feed Motor locked on	Follow corrective action for feed motor does not turn off symptom.
Excessive fuel spilling over the firepot into the ash wells and/or excessive flame	Excessive feeding/Feed Motor locked on	Follow corrective action for feed motor does not turn off.
Black soot on the side of the house	Exhaust path is dirty. Excessive feeding/Feed Motor locked on	Clean Exhaust path Follow corrective action for feed motor does not turn off symptom.
	Incorrect air-fuel ratio	Turn fuel adjustment trim dial to the LEFT to increase combustion air speed See "Trim Adjustment" section on Page 12.

**Following correction of any Alarm, turn the dial control to the OFF position, wait 10 seconds and turn back to desired setting OR unplug the appliance, wait 10 seconds then restore power.**

<b>Alarm (LED Flashing RED)</b>	<b>Possible Cause</b>	<b>Corrective Action</b>
1 Red Flash: Empty Hopper Alarm	Hopper empty	Fill the hopper
	Auger jam	Inspect the feed tube for jams
	Vacuum switch not closing	Make sure firebox door is shut, vacuum hose is connected to switch and drop tube, wire connectors are connected to vacuum switch, control board, hopper switch, and safety snap disc.
	Hopper lid open	Close the hopper lid
	Exhaust probe does not sense temperature	Secure the exhaust probe keeping its wire away from hot surfaces and clean the exhaust plenum
	Snap disc tripped (#3)	Reset snap disc
	Exhaust probe not attached to outlet	Inspect the exhaust probe to see if it is securely attached to the side of the exhaust outlet - keeping its wire away from hot surfaces
2 Red Flashes: Exhaust Probe Fail	Exhaust path is dirty	Clean appliance including the fire pot, exhaust path, and venting system
	Not connected to the control board	Connect terminal end to control board
4 Red Flashes: Missed Ignition	Failed component	Replace exhaust probe – securing it to exhaust blower housing – keeping wire away from hot surfaces
	Hopper empty	Fill the hopper
	Feed motor doesn't turn	Inspect feed motor circuit (hopper lid must be closed, vacuum switch must be closed, snap disc closed, and feed motor must be plugged in) Clear jam in feed tube
	Dirty appliance	Clean appliance including the fire pot, exhaust path, and venting system
	Igniter has no power or is defective	Check igniter lead connections or replace igniter
	Exhaust probe not properly installed	Secure exhaust probe to exhaust blower housing – keeping its wire away from hot surfaces
8 Red Flashes: Exhaust Over-Temp	Igniter chamber plugged with debris	Clean igniter chamber
	Feed Motor Locked On	Repair wire(s) and replace control board
	Non-approved fuel used	Only use wood pellet fuel. Do not enhance its performance with any other combustible substance.
	Convection blower dirty	Clean impellers

**Table 23.1**





B. Service Parts List

**QUADRA-FIRE**® Service Parts

Pellet Cabinet Style Stove

**OUTFITTER-II**

Beginning Manufacturing Date: Jul 2022  
Ending Manufacturing Date: Active

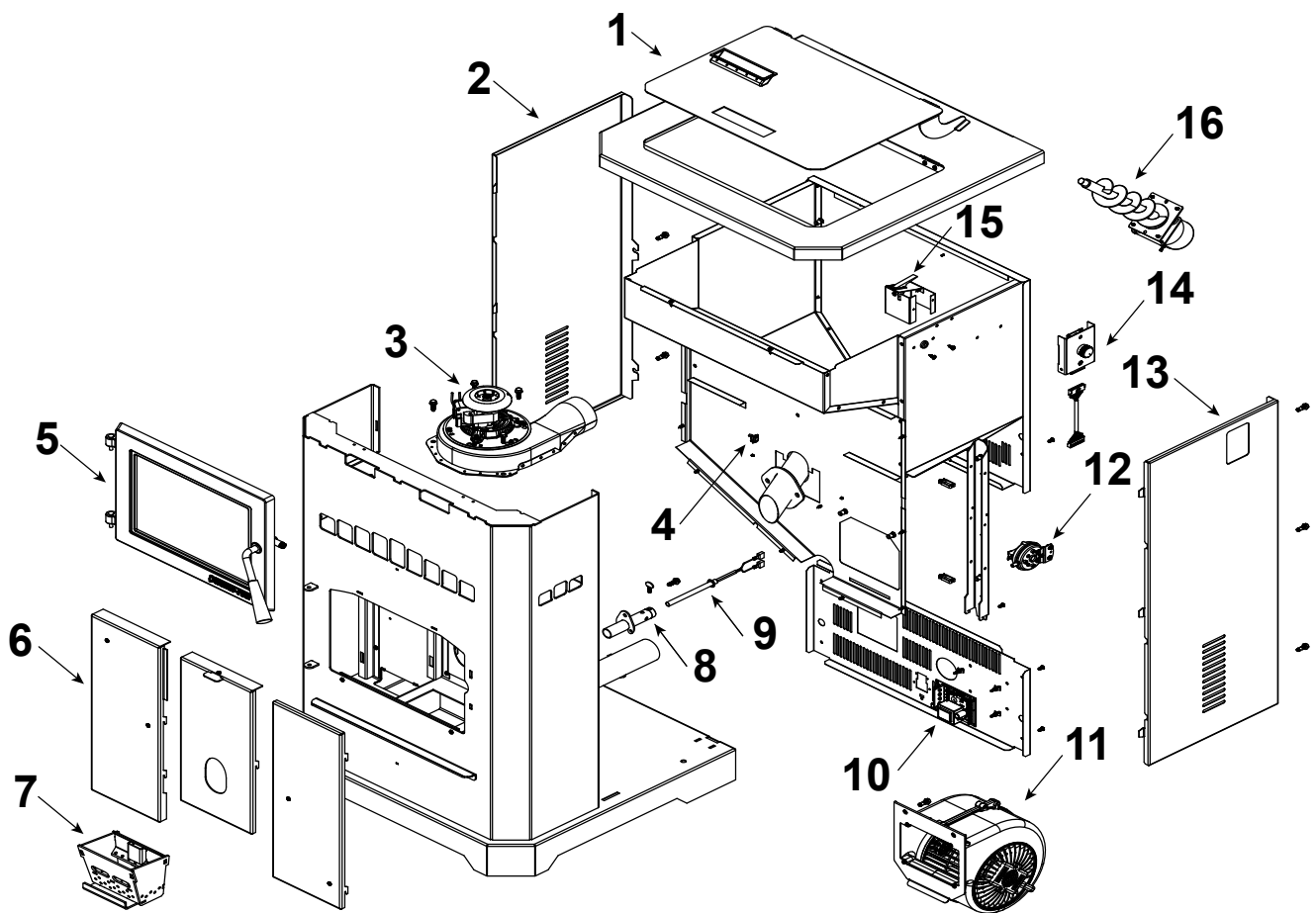

Part number list on following pages.

09/22

Beginning Manufacturing Date: Jul 2022  
Ending Manufacturing Date: Active

IMPORTANT: THIS IS DATED INFORMATION. When requesting service or replacement parts for your appliance please provide model number and serial number. All parts listed in this manual must be ordered from a dealer.



**Stocked  
at Depot**

ITEM	DESCRIPTION	COMMENTS	PART NUMBER	
1	Hopper Lid Assembly		SRV7086-019	
	Hopper Extension		PPHE200	
	Handle, Hopper Lid		SRV200-0110	
2	Side Curtain, Left Hand		SRV7086-154	Y
3	Exhaust Combustion Blower		812-4400	Y
	Gasket, Between Blower Housing and Stove		SRV240-0812	Y
	Gasket, Between Blower Housing and Motor		812-4710	Y
4	Snap disc, Manual Reset		SRV230-0080	Y

## #5 Door Assembly

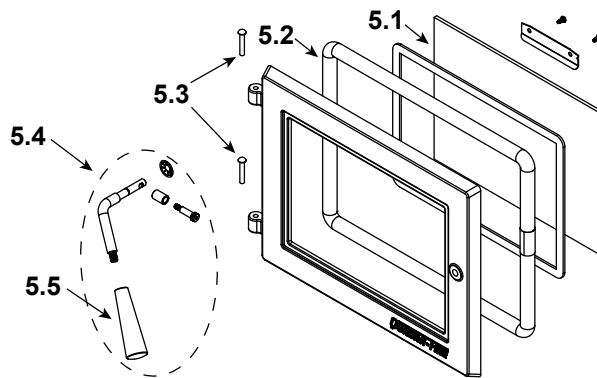

5	Door Assembly		SRV8105-021	Y
5.1	Glass Assembly		SRV8105-173	
5.2	Rope, Door, 3/4" x 84"		832-1680	
5.3	Hinge Pins	Pkg of 2	433-1590/2	
5.4	Threaded Handle Assembly Kit		SRV7093-024D	Y
5.5	Handle Black Phenolic Kit		KS-5140-1442	Y
6	Baffle Kit		SRV7077-006	
7	Firepot		SRV7077-003	Y
8	Igniter Chamber Kit		SRV7077-110	
9	Igniter Kit		SRV7000-660	Y
10	Control Board**		SRV8105-050	Y
11	Convection Blower		KS-5020-1052	Y
	Convection Blower Gasket		SRV7081-195	
	Convection Blower Bracket		SRV7081-210	
12	Vacuum Switch		SRV7000-531	Y
	Vacuum Hose, 5/32 ID	3 Ft	SRV240-0450	Y
	Hose, Barb Assembly		SRV229-0920	
13	Side Curtain, Right Hand		SRV7086-153	Y
14	Dial Control		SRV7080-036	Y
	Wire Harness, Dial Control		SRV7000-667	Y
15	Hopper Switch		SRV7000-612	Y

\*\*Fuse for the control board can be sourced locally, not a warranty item. Specs are 250V, 5A fuse, 20mm long x 5mm dia.

See Following page for additional service parts

Beginning Manufacturing Date: Jul 2022  
Ending Manufacturing Date: Active

IMPORTANT: THIS IS DATED INFORMATION. When requesting service or replacement parts for your appliance please provide model number and serial number. All parts listed in this manual must be ordered from a dealer.



**Stocked  
at Depot**

ITEM	DESCRIPTION	COMMENTS	PART NUMBER	
<p><b>#16 Feed Assembly</b></p>				
16	Feed Assembly Kit		SRV7077-014	Y
16.1	Feed Motor		SRV7000-670	Y
16.2	Feed Shaft Bushing	Pkg of 2	7000-600/2	Y
	Power Cord		812-1180	Y
	Component Pack		SRV8105-028	
	Exhaust Probe		SRV7000-669	Y
	Wire Harness		SRV7093-184	Y
	Wire Clip	Pkg of 10	7000-400/10	Y
	Thermostat		SRV8320-001	Y
<b>Accessories</b>				
	Outside Air Kit		811-0872	
	Top Vent Kit		TPVNT-7	
	Gasket Clean Out Top Flue		SRV411-1130	

### C. Wiring Schematic for Control Board

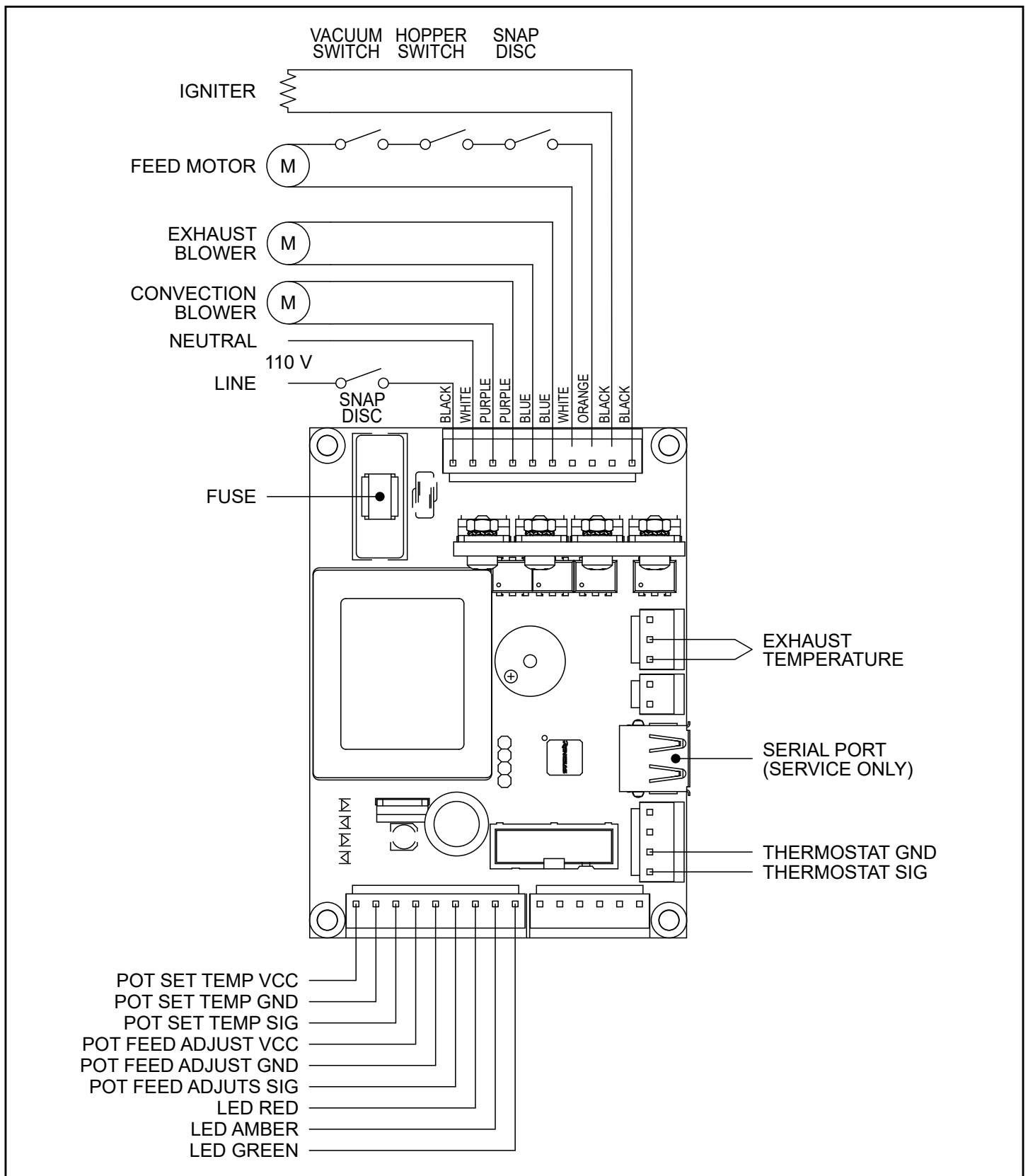



# QUADRA-FIRE®

NOTHING BURNS LIKE A QUAD

## CONTACT INFORMATION

Hearth & Home Technologies  
352 Mountain House Road  
Halifax, PA 17032  
Division of HNI INDUSTRIES

Please contact your Quadra-Fire dealer with any questions or concerns.  
For the number of your nearest Quadra-Fire dealer  
log onto [www.quadrafire.com](http://www.quadrafire.com)



## CAUTION



### DO NOT DISCARD THIS MANUAL

- Important operating and maintenance instructions included.
- Read, understand and follow these instructions for safe installation and operation.
- Leave this manual with party responsible for use and operation of this appliance.



### We recommend that you record the following pertinent information for your heating appliance.

Date purchased/installed: \_\_\_\_\_

Serial Number: \_\_\_\_\_

Location on appliance: \_\_\_\_\_

Dealership purchased from: \_\_\_\_\_

Dealer Phone: 1(     )     -     \_\_\_\_\_

Notes:  
\_\_\_\_\_  
\_\_\_\_\_  
\_\_\_\_\_

This product may be covered by one or more of the following patents: (United States) 5341794, 5263471, 6688302, 7216645, 7047962 or other U.S. and foreign patents pending.



HEARTH & HOME  
technologies™