

IMPORTANT:
THESE INSTRUCTIONS ARE TO
REMAIN WITH THE HOMEOWNER

**PACIFIC
ENERGY**

SERIAL #

SAFETY NOTICE

If this stove is not properly installed, a house fire may result. For your safety, follow the installation instructions. Contact local building or fire officials about restrictions and installation inspection requirements in your area.

INSTALLATION AND OPERATING INSTRUCTIONS



TESTED and LISTED to CAN/ULC S627
AND UL 1482
Meets the Environmental Protection Agency's
May 2015 Particulate Emission Standards

MODEL - NEO 2.5 NEOSTONE

SERIES - A



Contents

Safety	3
Chimney Smoke and Creosote Formation.....	3
Chimney Fires.....	3
In Case of a Chimney Fire.....	3
Avoiding a Chimney Fire.....	3
Operation	4
Wood Selection.....	4
How to Test Your Wood.....	4
Lighting a Fire.....	4
Normal Operation.....	4
Restarting After Extended or Overnight Burns.....	5
Over Firing.....	5
Average Heat Output Calculation.....	5
Proper Draft.....	5
Ash Removal.....	5
Disposal of Ashes.....	5
Storing Wood Beneath Unit.....	5
Maintenance	6
Baffle Removal.....	6
Maintenance Checks	7
NEO 2.5 Dimensions	8
Crate Removal.....	8
Soapstone	8
Removal and Installation:.....	8
Table top leveling:.....	9
Ember Protection	10
Combustion Air	10
Residential Installation	11
Clearances.....	11
Chimney and Connector.....	11
Single-Wall Connector(smoke pipe).....	11
Procedure.....	11
Mobile Home Installation	15
Additional Requirements.....	15
Clearances.....	15
Procedure:.....	15
Optional Blower	16
Blower Operation.....	16
Optional Outside Air Adaptor.....	16
Troubleshooting	17
Replacement Parts - NEO 2.5.....	18
Understanding & Operating Your Pacific Energy Stove.....	19
Firebrick Installation Instructions	20
Warranty Information	21
Label.....	23

PLEASE SAVE THESE INSTRUCTIONS

This manual describes the installation and operation of the Pacific Energy, NEOSTONE 2.5 Freestanding wood heater. This heater meets the 2015 U.S. Environmental Protection Agency's crib wood emission limits for wood heaters sold after May 15, 2015. Under specific test conditions this heater has been shown to deliver heat at rates ranging from 9,200 to 34,800 Btu/hr.

NOTE: WE STRONGLY RECOMMEND THAT SMOKE AND CARBON MONOXIDE DETECTORS BE INSTALLED IN THE AREA WHERE THE HEATER IS TO BE INSTALLED.

If smoke detectors have been previously installed, you may notice that they are operating more frequently. This may be due to curing of stove paint or fumes caused by accidentally leaving the fire door open. Do not disconnect the detectors.

SAFETY NOTICE: If this stove is not properly installed, a house fire may result. For your safety, follow the installation instructions. Contact local building or fire officials about restrictions and installation inspection requirements in your area.

Please read this entire manual before you install and use your new room heater. Failure to follow instructions may result in property damage, bodily injury, or even death.

Safety

Chimney Smoke and Creosote Formation

When wood is burned slowly, it produces tar and other organic vapours, which combine with expelled moisture to form creosote. The creosote vapours condense in the relatively cool chimney flue of a slow burning fire. As a result, creosote residue accumulates on the flue lining. When ignited, this creosote makes an extremely hot fire. The chimney connector and chimney should be inspected periodically (at least once every two months) during the heating season to determine if a creosote buildup has occurred. If creosote has accumulated (3 mm. or more), it should be removed to reduce the risk of a chimney fire.

1. Highest smoke densities and emissions occur when a large amount of wood is added to a bed of hot coals and the air inlet is closed. The heated wood generates smoke, but without ample air, the smoke cannot burn. Smoke-free, clean burning requires small fuel loads, two or three logs at a time or 1/4 to 1/2 of fuel load and leaving the air inlet relatively wide open, especially during the first 10 to 30 minutes after each loading, when most of the smoke generating reactions are occurring. After 30 minutes or so, the air inlet can be turned down substantially without excessive smoke generation. Wood coals create very little creosote-producing smoke.
2. The cooler the surface over which the wood smoke is passing, the more creosote will be condensed. Wet or green wood contributes significantly to creosote formation as the excess moisture that is boiled off cools the fire, making it difficult for the tars and gases to ignite, thus creating dense smoke and poor combustion. This moisture-laden smoke cools the chimney, compounding the problem by offering the smoke the ideal place to condense.
In summary, a certain amount of creosote is inevitable and must be lived with. Regular inspection and cleaning is the solution. The use of dry, seasoned wood and ample combustion air will help to minimize annoying smoke emissions and creosote buildup.

Chimney Fires

The result of excessive creosote buildup is a chimney fire. Chimney fires are dangerous. Chimney inside temperatures can exceed 2000° F(1100°C). This causes much higher than normal temperatures in the chimney and on its exterior surfaces. Thus ignition of nearby or touching combustible material is more likely during a chimney fire. Proper clearances are critical during such a fire.

Chimney fires are easy to detect; they usually involve one or more of the following:

- Flames and sparks shooting out of the top of the chimney
- A roaring sound
- Vibration of the chimney

In Case of a Chimney Fire

1. Prepare to evacuate to ensure everyone's safety. Have a well understood plan of action for evacuation. Have a place outside where everyone is to meet.
2. Close air inlet on stove.
3. Call local fire department. Have a fire extinguisher handy. Contact your local municipal or provincial fire authority for further information on how to handle a chimney fire. It is most important that you have a clearly understood plan on how to handle a chimney fire.
4. After the chimney fire is out, the chimney must be cleaned and checked for stress and cracks before starting another fire. Also check combustibles around the chimney and the roof.
- The services of a competent or certified installer, (certified by the Wood Energy Technical Training program (WETT) - in Canada, Hearth Education Foundation (HEARTH) - in U.S.A.,) are strongly recommended.

Avoiding a Chimney Fire

There are two ways to avoid chimney fires:

1. Do not let creosote build up to a point where a big chimney fire is possible.
2. Do not have fires in the heater that may ignite chimney fires. These are hot fires, such as when burning household trash, cardboard, Christmas tree limbs, or even ordinary fuel wood; (e.g.. with a full load on a hot bed of coals and with the air inlet excessively open.)



Operation

CAUTION: Never use gasoline, gasoline type lantern fuel, kerosene, charcoal lighter fluid or similar liquids to start or "freshen up" a fire in this heater. Keep all such liquids well away from the heater while it is in use.

CAUTION: Hot while in operation. Keep children, clothing and furniture away. Contact may cause skin burns.

Your PACIFIC ENERGY heater is designed for many years of trouble free operation. Over firing the appliance will shorten the life of the product. Failure to recitify an over firing condition can be hazardous and may void the manufacturer's warranty.

NOTE: Left and Right as referred to in this manual are considered your left and right when facing the front of the woodstove.

Wood Selection

This heater is designed to burn natural wood only. Higher efficiency and lower emissions generally result when burning air-dried seasoned hardwoods, as compared to softwoods or to green or freshly cut hardwoods.

Wood should be properly air dried (seasoned) for six months or more. Wet or undried wood will cause the fire to smoulder and produce large amounts of creosote. Wet wood also produces very little heat and tends to go out often.

DO NOT BURN :

- | | |
|--|---------------------------|
| -Salt water wood * | -Treated wood |
| -Wet or green wood | -Coal/charcoal |
| -Garbage* | -Solvents |
| -Lawn clippings/yard waste | -Unseasoned wood |
| -Railroad ties | -Manure or animal remains |
| -Materials containing rubber, including tires | |
| -Materials containing plastic | |
| -Waste petroleum products, paints or paint thinners, or asphalt products | |
| -Materials containing asbestos | |
| -Construction or demolition debris | |
| -Paper products, cardboard, plywood, or particleboard. | |

* **These materials contain chlorides which will rapidly destroy metal surfaces and void warranty.**

Burning these materials may result in the release of toxic fumes or render the heater ineffective and cause smoke.

The prohibition against burning these materials does not prohibit the use of fire starters made from paper, cardboard, saw dust, wax and similar substances for the purpose of starting a fire in an affected wood heater.

Do not burn anything but wood. Other fuels, eg. charcoal, can produce large amounts of carbon monoxide, a tasteless, odourless gas that can kill. Under no circumstances should you attempt to barbecue in this heater.

How to Test Your Wood

Add a large piece of wood to the stove when it has a good large bed of coals. It is dry if it is burning on more than one side within one minute. It is damp if it turns black and lights within three minutes. If it sizzles, hisses and blackens without igniting in five minutes it is soaked and should not be burnt.

Lighting a Fire

WARNING: Never use chemicals or any other volatile liquid to start a fire.

1. Adjust air control to "High" position(all the way to the left) and open door.
2. Place crumpled newspaper in the centre of the heater and criss-cross with several pieces of dry kindling. Add a few small pieces of dry wood on top.
3. Ignite the paper and leave the door ajar approximately 1/2"(13mm) - 1"(25mm) until the wood kindling is fully engulfed in flame.
4. After the kindling is fully engulfed add a few small logs. Close door.
5. Begin normal operation after a good coal base exists and wood has charred.

Curing of the Paint Finish

When burning your stove for the first 2-3 times it is very important that the room be well ventilated. Open all windows and doors. Smoke and fumes caused by the curing process may cause discomfort to some individuals.

Normal Operation

WARNING: This wood heater has a manufacturer-set minimum low burn rate that must not be altered. It is against federal regulations to alter this setting or otherwise operate this wood heater in a manner inconsistent with the operating instructions in this manual.

1. Set air control to a desired setting. If smoke pours down across the glass (waterfall effect) this indicates you have shut the control down too soon or you are using too low a setting. The wide range control makes finding the desired setting for your application easy. As every home's heating needs vary (ie. insulation, windows, climate, etc.) the proper setting can only be found by trial and error and should be noted for future burns.
2. To refuel, adjust air control to "High" position(all the way to the left), and give the fire time to brighten. Open the door slowly, this will prevent backpuffing or flame roll-out.
3. Use wood of different shape, diameter and length (recommended 18"(457mm)). Load your wood and try to place the logs so that the air can flow between them. Always use dry wood.
4. Do not load fuel to a height or in such a manner that would be hazardous when opening the door.

- For extended or overnight burns, unsplit logs are preferred. Remember to char the wood completely on "High" setting before adjusting air control to the "Low" setting for overnight burn.

WARNING: Always keep loading door closed when burning. This heater is not designed for open door burning. WARNING: No alteration or modification of the combustion air control assembly is permitted. Any tampering will void warranty and could be very hazardous.

WARNING: Do not use grates or andirons to elevate the fuel. Burn directly on the fire bricks. Replace broken or missing bricks. Failure to do so may create a hazardous condition.

Restarting After Extended or Overnight Burns

- Open door and rake hot embers towards the front of the heater. Add a couple of dry, split logs on top of embers, close door.
- Adjust air control to high and in just a few minutes, logs should begin burning.
- After wood has charred, reset air control to desired setting.
- To achieve maximum firing rate, set control to "High" position (all the way to the left). Do not use this setting other than for starting or preheating fresh fuel loads.

DO NOT OVERFIRE THIS HEATER: Attempts to achieve heat output rates that exceed heater design specifications can result in permanent damage to the heater and chimney.

Over Firing

Over firing can be caused by operating the unit with the door open, damage to door gaskets allowing excess air to enter the firebox, the use of kiln dried lumber, mill ends or paper waste and prolonged or continual use on a high burn setting.

Average Heat Output Calculation

Seasoned wood has approximately 7500 BTU's per pound.

The calculation is as follows:

$$\frac{\text{Amount of wood in lbs. X 7500 BTU's}}{\text{Burn rate in Hrs.}} \times .8 (80\% \text{ Avg. Efficiency})$$

Experience will give you the right settings for proper combustion and efficient burning. Remember the correct air inlet setting is affected by variables such as type of wood, outside temperature, chimney size and weather conditions. With practice, you will become proficient in operating your heater and will obtain the performance for which it was designed.

Proper Draft

- Draft is the force which moves air from the appliance up through the chimney. The amount of draft in your chimney depends on the length of the chimney, local geography, nearby obstructions and other factors.
- Too much draft may cause excessive temperatures in the appliance. An uncontrollable burn or a glowing red stove part or chimney indicates excessive draft.
- Inadequate draft may cause backpuffing into the room and plugging of the chimney. Smoke leaking into the room through appliance and chimney connector joints indicates inadequate draft.

Ash Removal

Caution: Ashes are to be removed only when the heater is cold. Whenever ashes get 3(76mm) to 4(102mm) inches deep in your firebox, and when fire has burned down and cooled, remove excess ashes. Leave an ash bed approximately 1" (25 mm) deep on the firebox bottom to help maintain a hot charcoal bed for future fires.

Optional Ash Cleanout system: The ash dump handle is located under the ash lip on the left hand side behind the lower grill. To operate ash dump, lift and tilt the lower grill down, pull handle out 1/2"(12mm) and turn clockwise. This will unlock the ash dump and allow it to open. Hold handle open while pulling ashes into the opening. Avoid large embers as these still contain heat value. Release handle and push in to lock. Ensure ash dump door is properly engaged. Fill the cavity with the remaining ash level with the firebox floor. Lift and pull out ashpan and discard ashes into metal container. Replace ashpan and ensure it is seated properly.

Do not burn with ash dump door open. Doing so will create a hazardous condition.

Disposal of Ashes

Ashes should be placed in a metal container with a tight fitting lid. The closed container of ashes should be placed on a non-combustible floor or on the ground, well away from all combustible materials, pending final disposal. If the ashes are disposed of by burial in soil or otherwise locally dispersed, they should be retained in closed container until all cinders have thoroughly cooled. Other waste should not be placed in this container.

Storing Wood Beneath Unit

It is possible to store wood between the stove pedestals, underneath the unit. The wood must not extend further forward than flush with the pedestals. Do not store paper or other stove lighting devices within the pedestal area. Although storing wood under the unit is possible it is not recommended. NOTE: Refer to local fire codes, CAN-B365 and NFPA 211 in the U.S..

WARNING: IF YOU CHOOSE TO STORE WOOD BENEATH YOUR UNIT, EXERCISE EXTREME CAUTION WHEN LOADING THE WOODSTOVE. EMBERS CAN FALL AND MAY IGNITE WOOD BENEATH STOVE.

Maintenance

1. Burn cord wood only, dry and well seasoned. The denser or heavier the wood when dry, the greater its heat value. This is why hardwoods are generally preferred. Green or wet wood will cause a rapid buildup of creosote. If you feel it is necessary to burn wet or unseasoned wood, do so only with the air inlet set open enough to maintain a good strong fire and fairly high chimney temperatures. Do not attempt to burn overnight using green wood or wet wood. Wet wood can cause up to 25% drop in heater output, as well as contributing significantly to creosote buildup.

WARNING: Never use chemicals or any other volatile liquid to start a fire. Do not burn garbage, or flammable fluids such as gasoline, naphtha, or engine oil. We strongly recommend that smoke detectors be installed.

2. Remove ashes frequently. Embers can roll out the door and create a fire hazard.
3. If glass becomes darkened through slow burning or poor wood, it can readily be cleaned with fireplace glass cleaner when stove is cold. Never scrape with an object that might scratch the glass. The type and amount of deposit on the glass is a good indication of the flue pipe and chimney buildup. A light brown dusty deposit that is easily wiped off usually indicates good combustion and dry, well-seasoned wood and therefore relatively clean pipes and chimney. On the other hand, a black greasy deposit that is difficult to remove is a result of wet and green wood and too slow a burning rate. This heavy deposit is building up at least as quickly in the chimney.

WARNING: ONLY USE MATERIALS AND COMPONENTS SUPPLIED BY MANUFACTURER WHEN DOING MAINTENANCE OR REPLACEMENTS.

4. DOOR GASKETS - The gasket used by Pacific Energy (3/4"(19mm) round high density fiberglass rope) requires only light pressure to seal. This will prolong seal life. It is important that the door seal be maintained in good condition. Periodically inspect seals and replace if necessary with WODC.NEODGKIT.
5. DOOR GLASS - Do not slam loading door or otherwise impact glass. When closing door, make sure that no logs protrude to impact the glass. If the glass gets cracked or broken, **it must be replaced before using the stove.** Replacement glass can be obtained from your dealer. Use 18"(457mm) x 10-1/4"(260mm) x 5 mm. Ceramic glass only. **Do not substitute with any other type.**

To remove broken glass, remove the door gasket and then undo the eight screws securing the gasket guides and glass retainers. Remove all particles of glass. Be careful as they are very sharp. Install new glass complete with gasket. Replace glass retainers and gasket guides then install new door gasket as per instructions provided with the door gasket kit.

CAUTION:

- do not overtighten, tighten screws very carefully
 - do not clean glass when hot
 - do not use abrasive cleaners on glass
6. The area where boost combustion air enters the firebox must be kept clear of excessive ash buildup which will block air flow. This area is at the front of the firebox.
 7. Do not store wood within heater installation clearances, or within the space required for fuel loading and ash removal. Keep the area around the heater clean and free of loose combustibles, furniture, newspapers, etc.
 8. Establish a routine for the fuel, woodburning and firing technique. Check daily for creosote buildup until experience shows how often you need to clean to be safe.
 9. Be aware that the hotter the fire, the less creosote is deposited. Weekly cleaning may be necessary in mild weather, even though monthly cleaning is usually enough in the coldest months when burning rates are higher.
 10. Instruct all members of your family on the safe operation of the heater. Ensure they have enough knowledge of the entire system if they are expected to operate it. Stress the section on chimney fires and the importance of following the steps outlined "In Case of Chimney Fire".

Baffle Removal

Chimney connector pipe should be disconnected from stove to clean and inspect. Only if this is not possible should you remove baffle assembly. CAUTION: Ceramic blanket insulation is located on top of baffle. Do not use a vacuum in this area.

DO NOT OPERATE WITH BAFFLE ASSEMBLY OR INSULATION REMOVED.

Remove retaining pin at the back top of the firebox, just under the baffle. Lift baffle up and pull forward to disconnect from the supply tube. Tilt baffle sideways to drop down and remove from firebox. Re-install baffle assembly in reverse order.

WARNING: Sweep/Clean chimney with baffle installed or be sure to plug the top of the baffle tube in the back of the firebox before sweeping or cleaning. Failure to prevent ash or soot from falling into the baffle tube will cause incorrect operation and will lead to premature burn out of the tube or baffle.

Maintenance Checks

Check the following parts for damage such as cracks, excessive corrosion, burned out sections and excessive warping:
(See website for descriptions and more detail)

Some warping of the baffle is normal (up to 1/4" or 6mm). Replace if the baffle has permanent warping greater than this or has signs of cracking or breakage.

Weekly:

- Firebrick - for cracking.
- Door Gasket - sagging, placement, damage.

Monthly:

- Brick rail tabs and brick rails.
- Air riser tube in the back of the firebox.
- Back side of airwash chamber - located in the upper front of firebox.
- Baffle locking pin.
- Boost tube cover - located in center of manifold, bottom front of firebox.

When Cleaning the Chimney System:

- Top baffle board/blanket.
- Baffle.
- Brick Rails.
- Manifold - located in bottom front of firebox.

Blower:

- The blower should be cleaned out a minimum every six months by using a vacuum on the grill openings in the back and bottom of the blower casing to remove any dust and debris.

- Please contact your dealer if you experience any of the damage listed above. Continuing to operate your stove with broken parts may accelerate damage to other parts and may void your warranty

NEO 2.5 Dimensions

FIG. #1

NOTE: DIMENSION DOES NOT INCLUDE LEVELLING LEGS

NOTE: ALL DIMENSIONS IN INCHES[MM]

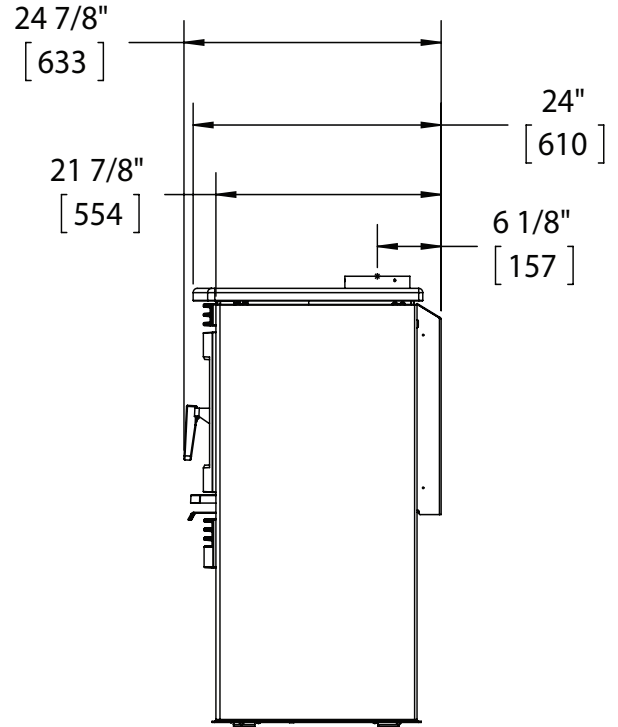
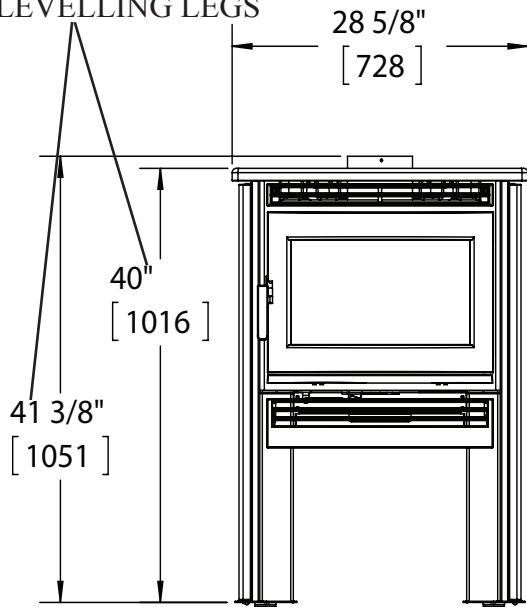

Crate Removal

- 1) Carefully remove wood top and supports.
- 2) Remove plastic cover.
- 3) Using a 7/16"(12mm) wrench, remove lag bolts that secure hold down brackets to bottom pallet.
- 4) Slide the hold down brackets away from the stove.

Soapstone

Removal and Installation:

NOTE: It is recommended that two people remove or install the Soapstone Top and Side Panels due to the high weight of the pieces. Soapstone can be easily scratched and damaged. Please be very careful when removing or installing the Top and Side Panel pieces and place pieces on a non-marring surface.

- 1) Lift the Top piece up off the pins at the front corners of the Top and from around the flue collar as shown in Fig. #2.

FIG. #2

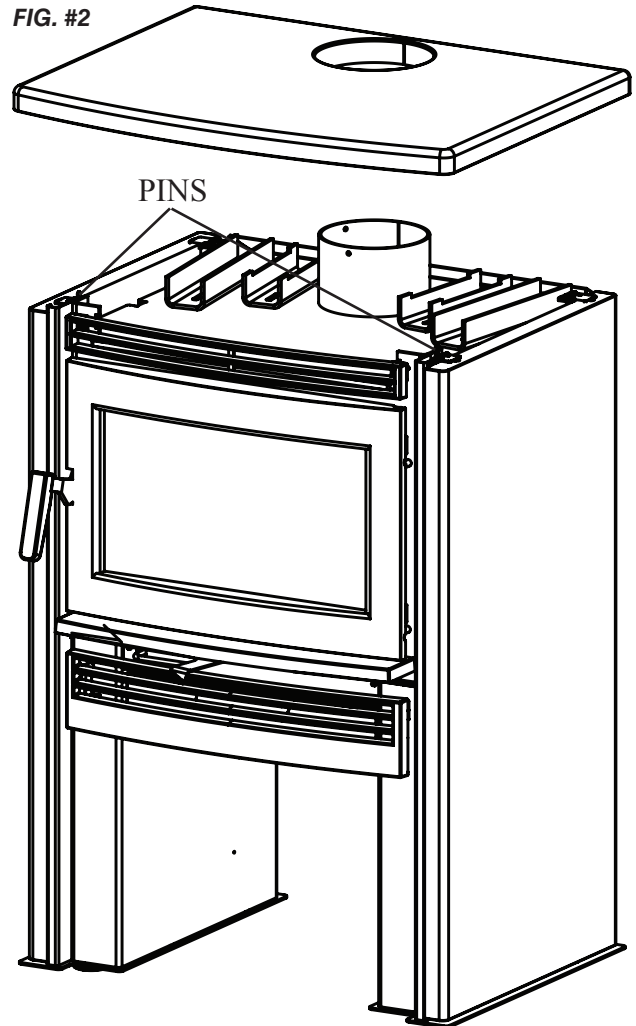

- 2) While supporting the side panel, remove the four screws securing the front and rear pin brackets to the top face of the Soapstone Side Panel. Fig. #3
- 3) Carefully lift the Soapstone Side Panel to disengage the pins from the hole in the bottom of the panel and pull the panel away from the unit. Fig. #4
- 4) Repeat steps 2 and 3 to remove the panel on the opposite side.
- 5) Reverse all steps to install Soapstone Side Panels and Top.

Table top leveling adjustment:

There are level adjustment bolts located underneath the table top on both the left front and right front side of the stove. If the table top rocks once installed, the table top needs to be leveled.

To adjust:

- 1) Ensure that the bolts on both sides are in their down position and are not making contact with the table top.
- 2) Raise either one of the adjustment bolts until it makes contact with the bottom of the table top. Use a 1/2" open end wrench or lift the table top high enough to fit your fingers in and turn the bolt.
- 3) Raise the bolt on the opposite side using the same method until the bolt on that side is also making contact. Check to determine if the table top is still able to rock. Repeat adjust-as needed.

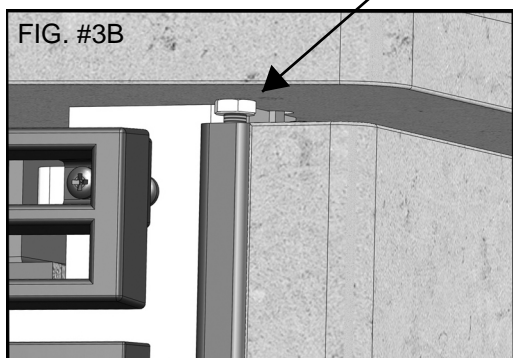
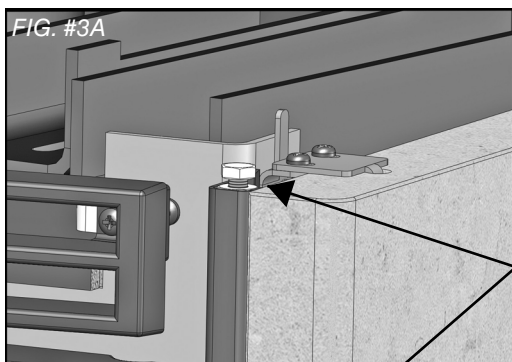
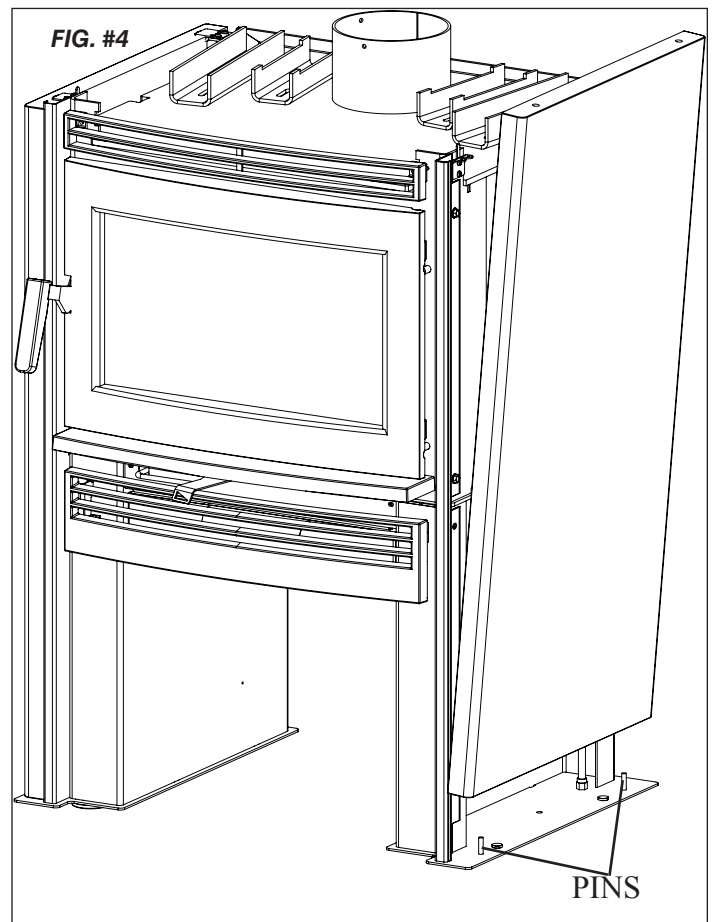
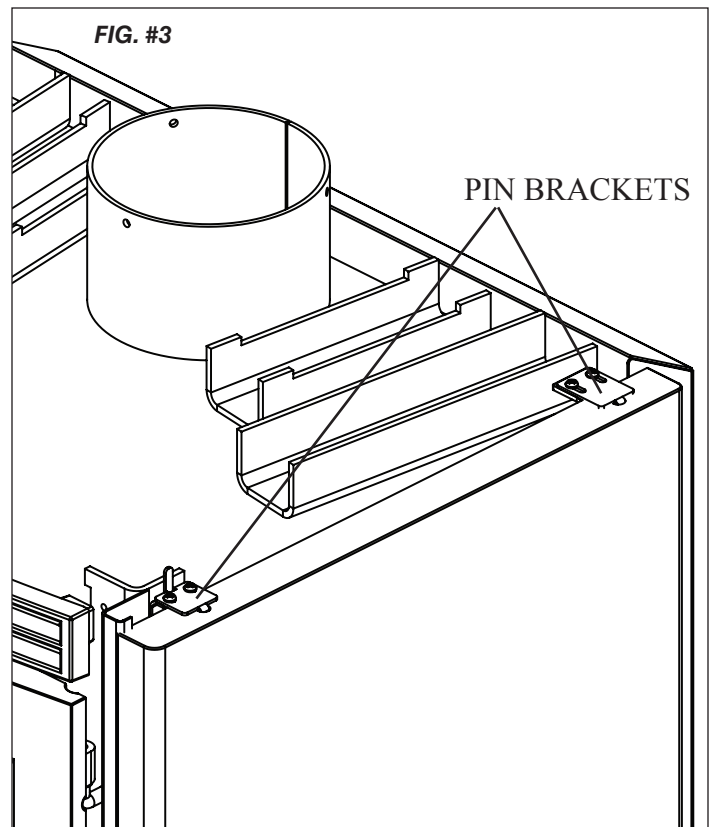

Ember Protection Combustion Air

The stove may be installed on a combustible floor provided ember protection made from a non-combustible material with a minimum K value of 23.7 btu/ft h °F is used. Equivalent to 20GA steel.

This protection must extend as follows:

In Canada: 18" (457 mm) on the firing side and 8" (203 mm) to the other sides. See Figure #5, below.

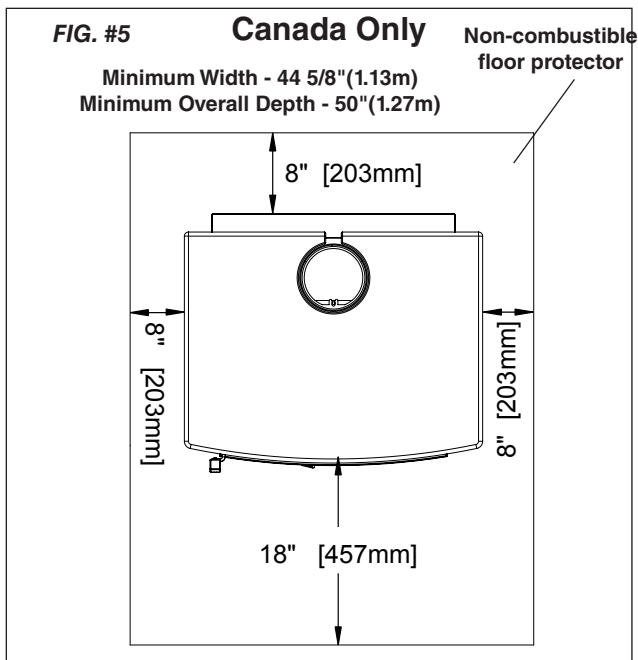

In USA: 16" (406 mm) to the front and 8" (203 mm) to the sides of the fuel loading door opening. See Figure #6, below. In the case of a horizontal chimney installation, this protection is also required under the chimney connector and 2" (51 mm) beyond each side.

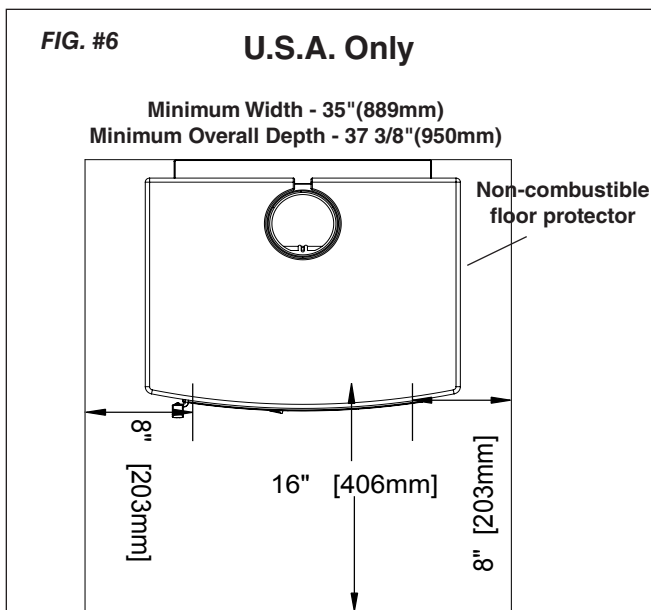

(Type 1 floor protector - approved to UL1618)
Minimum 20GA steel

Intake or combustion air can be supplied to the stove in one of two ways. Consult your local building code or CAN/CSA-B365, Installation Code for Solid-Fuel-Burning Appliances and Equipment before proceeding.

1. **Outside air supply** - (Necessary for mobile home installation, optional for residential installation.) Outside air may be drawn from either underneath the stove or from behind.

To draw outside air through the floor, leave the 4" (102mm) knockout or cover plate in place in the rear of the ash box enclosure.

Cut or drill a 4" (102mm) diameter hole directly below the bottom hole of the ash box enclosure. Connect enclosure to the floor with a short 4" (102mm) diameter pipe. If you wish to connect the outside air to the rear hole on the ash box, then remove the 4" (102mm) knockout or cover plate at the rear of the ash box.

This hole must get its air from a **ventilated** crawl space or be extended with duct to the outdoors (see Figure #8, Page 13). The use of outside combustion air for residential installation requires the unit to be secured to the structure to prevent dislodging of the air duct.

To draw outside air from behind the stove, an outside air adaptor may be required (see Optional Blower section). Cut or drill a 4" (102mm) hole through a wall behind the unit. Use an appropriate household 4" (102mm) inlet.

Note: This unit is not designed to be operated with the firing door open. In addition to the obvious hazard of sparks landing on combustibles, an open fire door will cause the heater to draw air from the living space and possibly cause suffocation.

2. **Room air supply** - The unit must have adequate air for combustion provided in the room the unit is installed in. Remove the cover plate or knockout from the rear of the ash box enclosure. The stove will now draw its air from the room through this opening and into the firebox intake.

Note: The living space around the heater must be well ventilated with good air circulation. Anything that may cause a negative pressure can cause gases or fumes to be pulled into the living area. During extremely cold weather, and especially when burning at very slow rates, the upper parts of the exposed chimney may ice up, partially blocking the flue gases. If blockage occurs, flue gases may enter living space.

Residential Installation

Warning: Under no circumstances is this heater to be installed in a makeshift or "temporary" manner. It may be fired only after the following conditions have been met.

- * DO NOT ATTEMPT TO CONNECT THIS HEATER TO ANY AIR DISTRIBUTION DUCT.
- * Do not connect this unit to a chimney flue serving another appliance.
- * Outside combustion air or fresh air into the room may be required in your area, consult local building codes (see Combustion Air section).

- The services of a competent or certified installer, (certified by the Wood Energy Technical Training program (WETT) - in Canada, or the Hearth Education Foundation (HEARTH) - in U.S.A.,) are strongly recommended.

BOTH CHIMNEY SYSTEM AND CONNECTOR MUST BE 6"(150mm) DIAMETER AND LISTED TO: IN CANADA - ULC-S-641 LISTED CONNECTOR AND ULC-S-629 LISTED CHIMNEY, IN USA - UL-103 HT LISTED CONNECTOR AND CHIMNEY

Clearances

1. This heater may be installed using a single-wall connector (smoke pipe) or listed double-wall connector (see Mobile Home installation).
2. Clearances to combustible surfaces and materials using single-wall connector are shown in Figure #7, page 12. Clearances may be reduced with various heat insulating materials. Consult local fire codes and authorities for approval.
3. Alternately, for close clearances, use a listed double-wall connector. See Fig #7 page 12.

It is possible to store wood between the stove supports, underneath the unit but not recommended. The wood must not extend further forward than flush with the supports.

NOTE: Refer to local fire codes, CAN-B365 in Canada and NFPA 211 in the U.S..

Chimney and Connector

Connect to a listed chimney or a chimney suitable for use with solid fuel that is lined and in good condition. Chimney flue exit is to be 3 feet (1 m.) above roof and two feet (0.6 m.) above highest projection within 10 feet (3 m.). The installation must meet all local codes. Minimum system height is 15 feet (4.6 m.) (measured from base of appliance).

- * The chimney connector should not pass through an attic, roof space, closet or similar concealed space, floor, or ceiling. Where passage through a wall, or partition of combustible material is desired, the installation shall conform to CAN/CSA-B365, Installation Code for Solid-Fuel-Burning Appliances and Equipment in Canada or NFPA 211: Standard for Chimneys, Fireplaces, Vents, and Solid Fuel-Burning Appliances in the U.S.A..

Double-Wall Connector

- Use a listed double-wall connector.(listed to ULC S641)
- Install all components to the chimney connector manufacturer's installation requirements.

Single-Wall Connector(smoke pipe)

Smoke pipe must be:

- * as short and straight as possible, use six inch diameter, 24GA or thicker black pipe that is clean and in new condition.
- * secured at every joint and collar with 3 sheet metal screws.
- * installed with the crimped or male ends pointing down. This will carry any liquid creosote or condensation back into the stove.

Procedure

1. If a listed chimney and double-wall connector is to be connected to the stove, install all components to the chimney manufacturer's installation requirements.
2. If a roof or ceiling support is used in the installation, you will find the chimney manufacturer's complete instructions packed with the roof support.
3. If it is desirable to use smoke pipe in conjunction with the insulated chimney, see step 4.
4. To start installing smoke pipe (chimney connector), slip crimped edge of the pipe inside the stove collar. Use holes provided in collar to secure pipe with three screws.
5. Install the remaining lengths of pipe one on top of the other to the finished height of the chimney connector up to the start of the chimney and secure to each other. (Outside combustion air may be required, consult local building codes. See Combustion Air section on page 10.)

NOTE: Longer chimney lengths and different pitch flashings may be used. All other parts installed must be listed(see Figure #8, Page 13). Install all components to the connector and chimney manufacturer's installation requirements. Consult your chimney supplier for additional installation advice.

6. Cut a hole in the ceiling and roof to suit the chimney system and frame in the sides. The chimney support is mounted to the framing.
7. Assemble chimney sections so the finished length is resting on the support and protruding through the roof. Avoid having joints between ceiling and roof. Install radiation shield. Assemble flashing and storm collar and be sure to maintain the vapour barrier at this point. (Seal securely.) Attach rain cap and check flashing for leaks.
8. Install connector as per manufacturer's instructions.

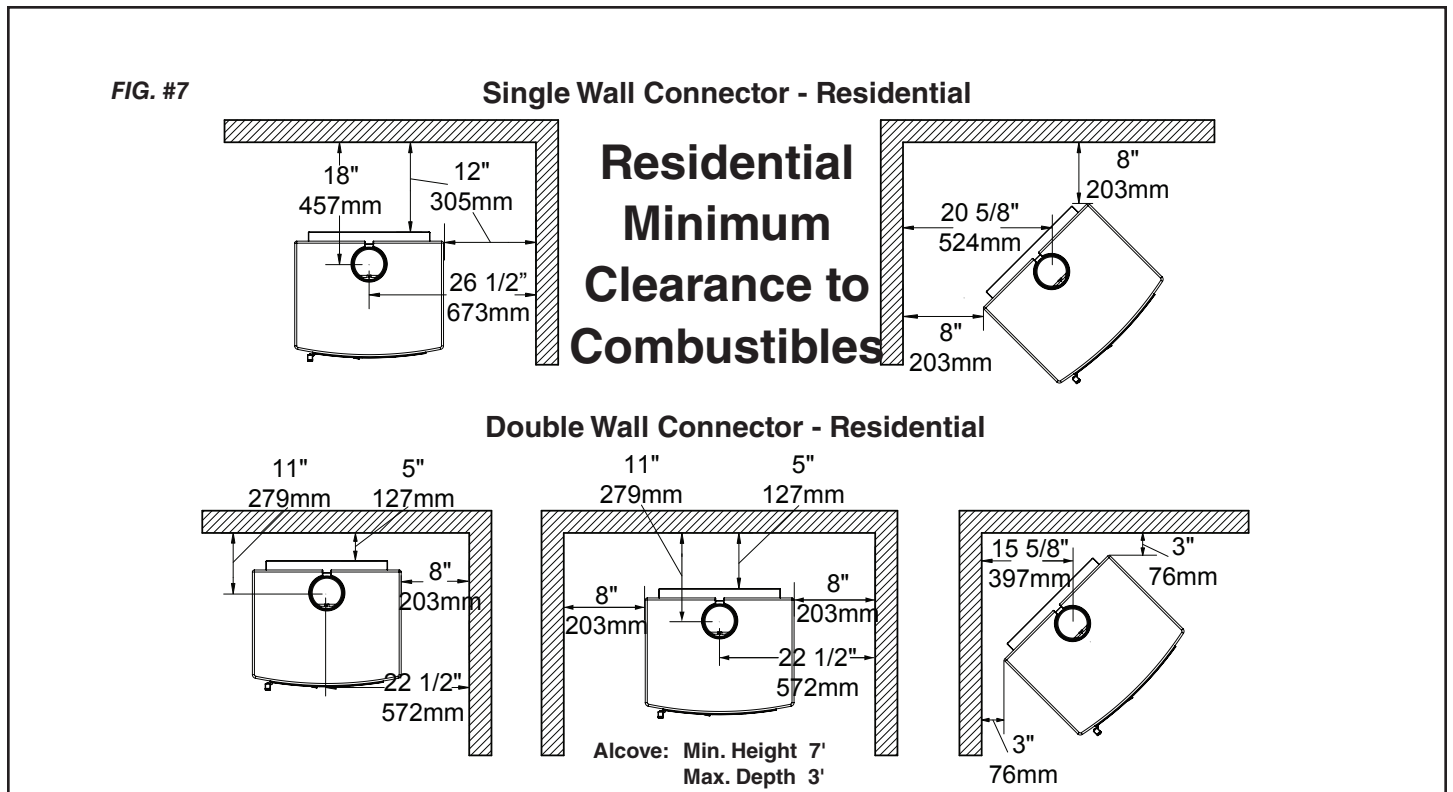
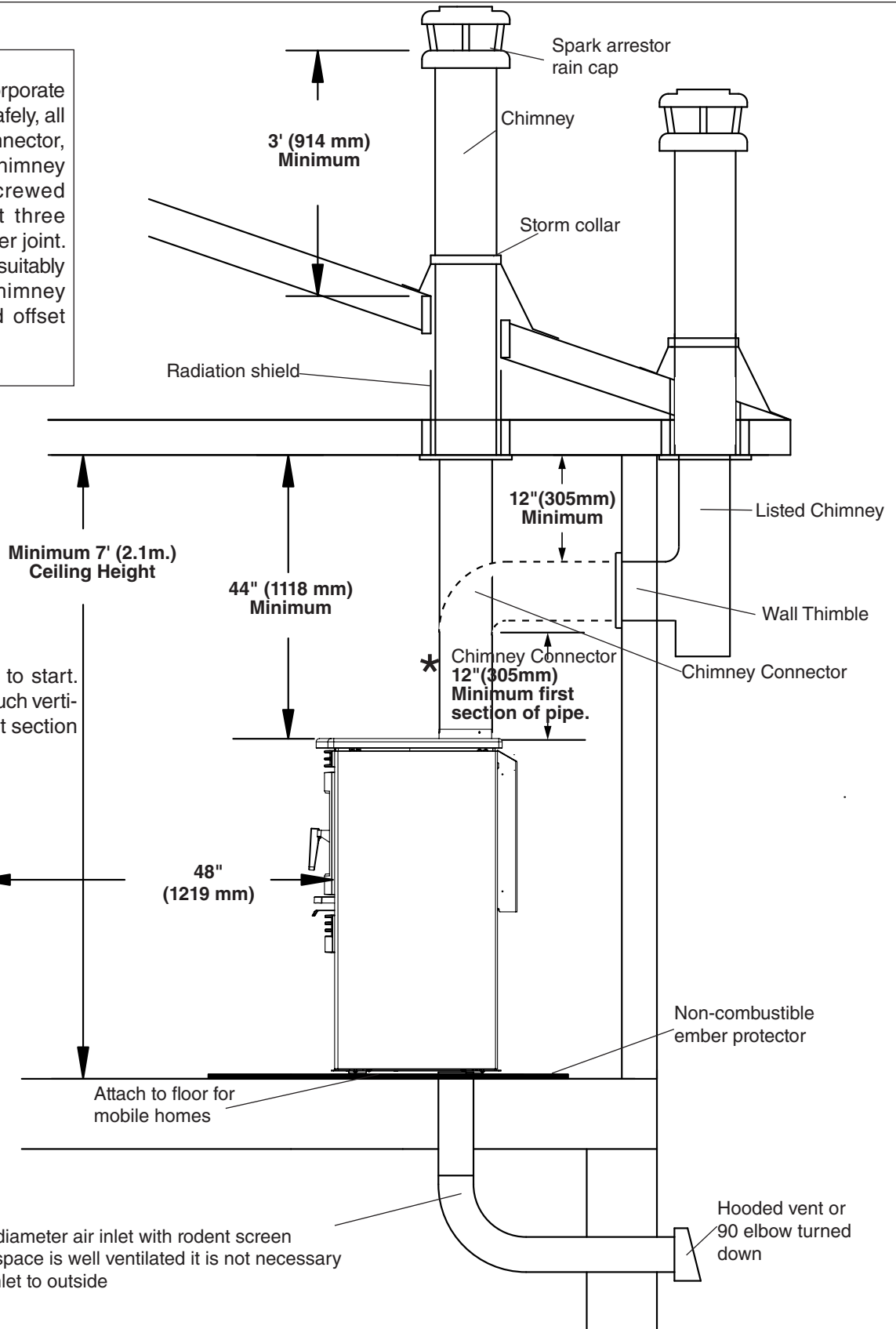

FIG. #8

The chimney may incorporate an offset. To do this safely, all sections of listed connector, offset elbows and chimney section must be screwed together by at least three sheet metal screws per joint. The chimney must be suitably supported by the chimney manufacturer's listed offset support.



* Unit may be harder to start. Please provide as much vertical length for the first section of pipe as possible.

- * 4" (102mm) diameter air inlet with rodent screen
- * If the crawl space is well ventilated it is not necessary to extend air inlet to outside

FIG. #9

Ensure that the Masonry chimney meets all National Fire Protection Association and local building codes. Have the chimney cleaned and inspected by a professional to ensure there are no cracks, weak mortar or other signs of deterioration. See pipe manufacturers installation instructions for further information

* Unit may be harder to start. Please provide as much vertical length for the first section of pipe as possible.

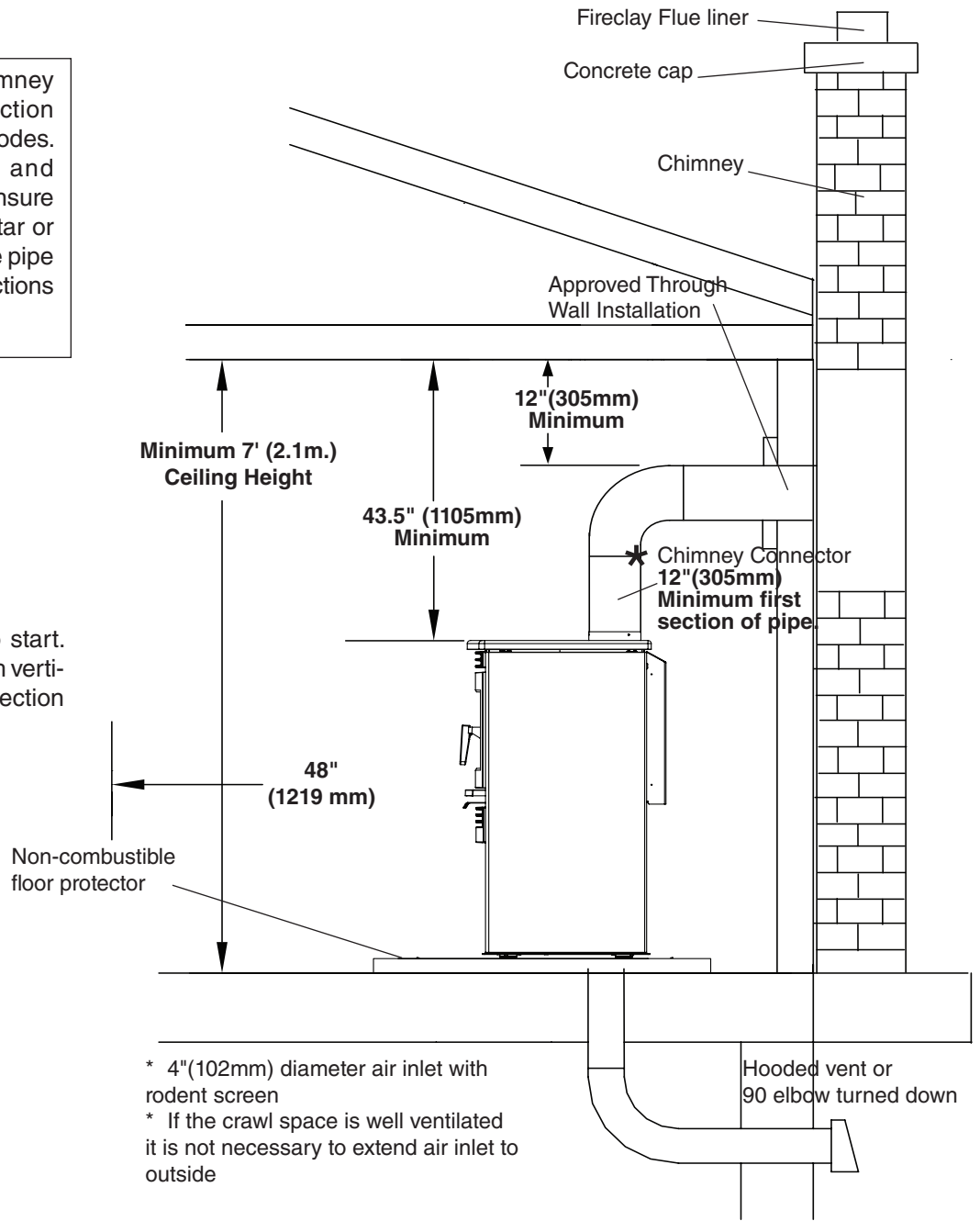

Mobile Home Installation

Additional Requirements

Warning: Under no circumstances is this heater to be installed in a makeshift or "temporary" manner. It may be fired only after the following conditions have been met.

- **DO NOT CONNECT THIS UNIT TO A CHIMNEY FLUE SERVING ANOTHER APPLIANCE.**
- **DO NOT INSTALL IN A SLEEPING ROOM.**
- **BOTH CHIMNEY SYSTEM AND CONNECTOR MUST BE 6"(150mm) DIAMETER AND LISTED TO: IN CANADA - ULC S-641 LISTED CONNECTOR AND ULC-S-629 LISTED CHIMNEY, IN USA - UL-103 HT LISTED CONNECTOR AND CHIMNEY**

- Outside air supply must be used for Mobile Home installations see Figure #8, Page 13.
- Remove the chimney down to the roof flashing to allow for transportation of the mobile home.

Procedure:

CAUTION: THE STRUCTURAL INTEGRITY OF THE MOBILE HOME FLOOR, WALL AND CEILING/ROOF MUST BE MAINTAINED.

- The services of a competent or certified installer, (certified by the Wood Energy Technical Training program (WETT) - in Canada, or the Hearth Education Foundation (HEARTH) - in U.S.A.,) are strongly recommended.

Note: See "Combustion Air" section on page 10.

1. Position stove and floor protection with hole for combustion air in accordance with the clearances as stated on the label and in Figure #10.
2. Mark the position for the hole in the ceiling and roof by using a string and plumb-bob.
3. Check that the intended location will not interfere with floor joists, ceiling joists or rafters before proceeding further.

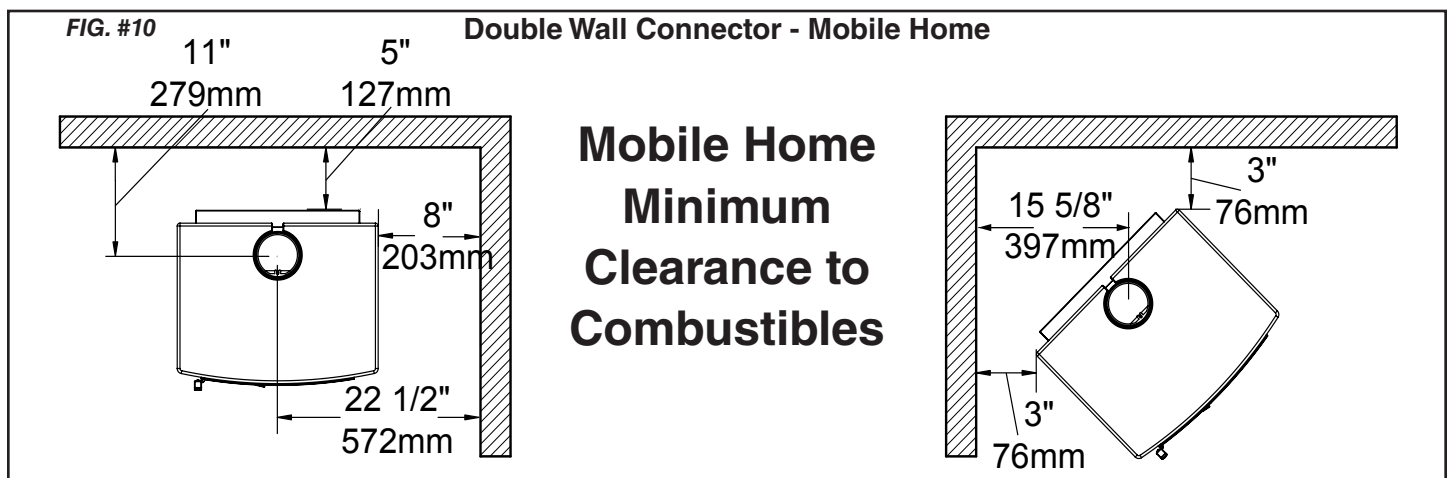

Clearances

This heater must be installed with a listed double-wall connector and compatible chimney system. Clearances to combustible surfaces and materials are shown in Figure #10.

Clearances may be reduced with various heat insulating materials. Consult local fire codes and authorities for approval.

NOTE: Longer chimney lengths and different pitch flashings may be used. All other parts installed must be listed (see Figure #8, Page 13). Install all components to the connector and chimney manufacturer's installation requirements. Consult your chimney supplier for additional installation advice.

4. Cut a hole in the ceiling and roof to suit the chimney system and frame in the sides. The chimney support is mounted to the framing.
5. If the chimney exits the mobile home less than 7 feet above the ground then a guard must be installed to cover the chimney up to a height of 7'(2.1m).
6. The guard must not have opening larger than 3/8"(9.5mm) and must maintain a space of 4"(102mm) minimum around the chimney.
7. Assemble chimney sections so the finished length is resting on the support and protruding through the roof. Avoid having joints between ceiling and roof. Install radiation shield. Assemble flashing and storm collar and be sure to maintain the vapour barrier at this point. (Seal securely.) Attach rain cap and check flashing for leaks.
8. Install connector and chimney as per manufacturer's instructions.
9. Attach stove to flooring using two 1/4"(6mm) x 2"(51mm) or longer lag screws.

Optional Blower

The optional blower kit (WODC.BLOW) is equipped with a three prong power cord and may be installed at any time. Follow installation instructions supplied with the kit. Route power supply cord away from heater.

Electrical rating: 115 volts A.C., 60Hz, .5 amps.
Fan output rating: 140 CFM

Blower Operation

Proper blower speed matched with air control setting will ensure peak performance from your stove. Operate as follows:

- Air control set to "L" (low), operate blower speed control on "Low".
- Air control set between "L" and "H" (low and high), operate blower speed control at desired setting.

Automatic: To operate the blower automatically, set the rocker switch on the side of the fan housing to "Auto" and set the speed control to desired setting. This will allow the fan to turn on as the stove heats up to operating temperature. It will also shut the blower off after the fire has gone out and the unit cooled to below a useful heat output range.

Manual: To manually operate the blower, set the rocker switch to "Man" and set the speed control to desired setting. This will bypass the sensing device and allow full control of the blower. Switching from "Auto" to "Man" or selecting speed may be done anytime.

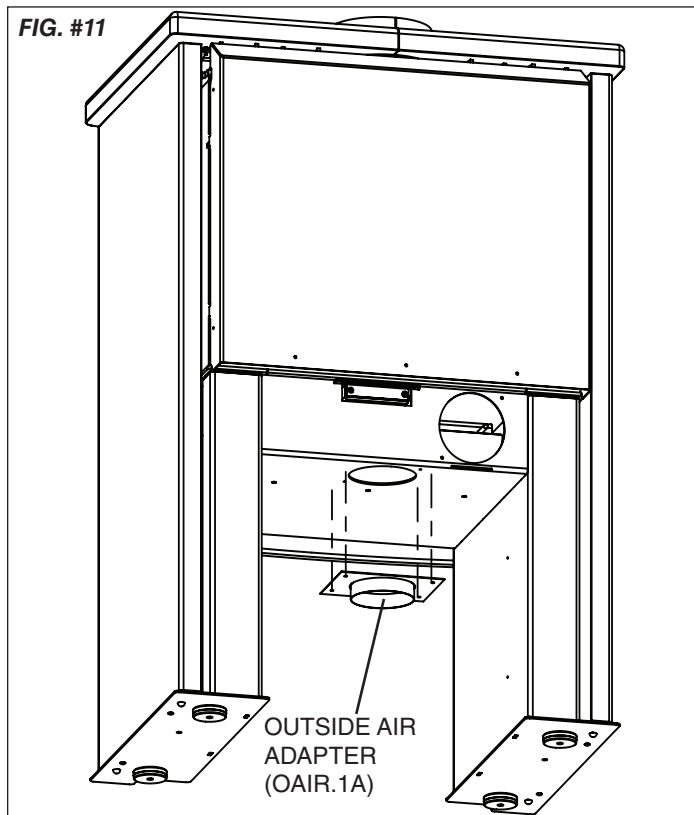

Optional Outside Air Adaptor

The adaptor(OAIR.1A) is only required if outside combustion air is being used.

Installation(OAIR.1A):

1. Place adaptor over the desired hole in either the bottom or rear of the leg adaptor and secure with #8 x 1/2" screws. Combustion air duct from outside can now be attached to the 4"(100mm) round collar.

NOTE: If using a WODC.BLOW then use the hole in the bottom of the leg adaptor.

2. Install the optional NE25 pipe shield.(NE25.78725) to cover the visible outside air intake pipe.

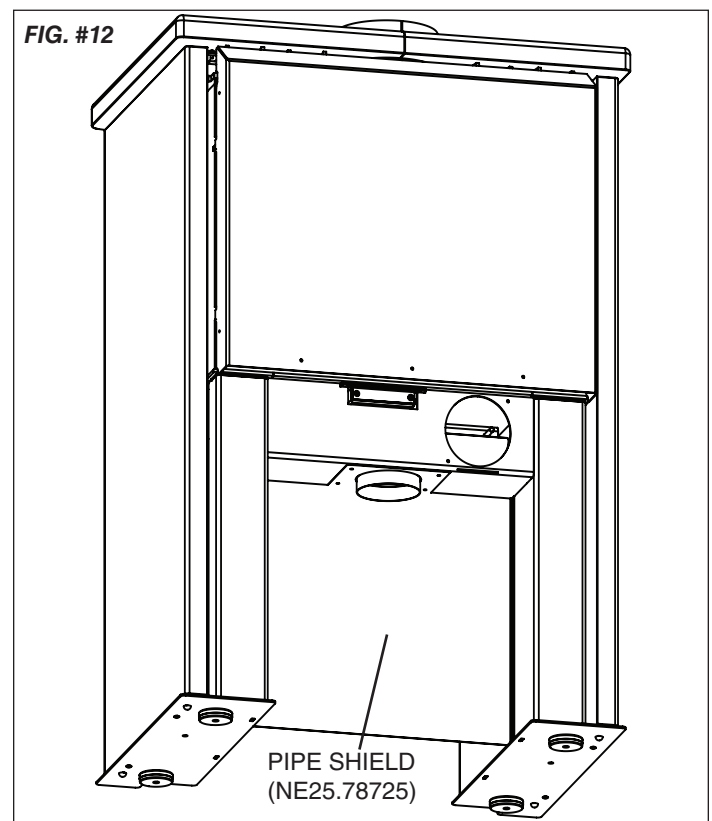

Troubleshooting

Problem	Cause	Cure
Glass is Dirty	1. Wood is wet	- Use dry wood
	2. Turning down air control or damper too soon	- Do not turn down until a) there is a good bed of coals b) the wood is charred
	3. Draft too low	- Improper chimney height and / or diameter - Chimney plugged or restricted, check flue - Provide outside air for combustion
	4. Door gasket leakage	- Replace gasket - Check latch
Excessive Creosote Buildup - See 1,2,3, above.		
Low Heat Output	1. Wood is wet	- Use dry wood
	2. Fire too small	- Build a larger fire
	3. Draft too low	- Chimney plugged or restricted, inspect and clean
Won't Burn Overnight	1. Air control is set too high	- Set control lower
	2. Not enough wood	- Unsplit wood is preferred for overnight burns
	3. Draft too high	- Excessive chimney height and/or diameter,
Stove Won't Burn	1. Combustion air supply blocked	- Check outside air supply for obstruction - Check that room air cover is removed
	2. Draft too low	- Chimney plugged or restricted, inspect and clean - Chimney oversized or otherwise unsuitable, consult Dealer

Replacement Parts - NEO 2.5

(WHEN ORDERING, INCLUDE PART NUMBER WITH DESCRIPTION)

ITEM	DESCRIPTION	PART NO.
1.....	Soapstone Panel Set.....	????
3.....	Door Catch	NE16.7825
4.....	Ash Lip	NE25.5037901
5.....	Gasket Guides (4 pc.)	NE25.7840
6.....	Replacement Glass (c/w Tape)	NE25.5034900
7.....	Door Gasket Kit.....	WODC.NEODGKIT
8.....	Door Casting, Black.....	NE25.5037900
9.....	Door Handle Assembly.....	NE16.7817
10.....	Side Panel Spacer.....	7103.15-A
11.....	Firebrick Set	NE25.BRIC
12.....	Brick Rail, Left/Right.....	NE25.RAILSET
13.....	Replacement Baffle Kit.....	NE25.BAFKIT
14.....	Baffle Pin	SSER.125001
15.....	Ash System Front Brace.....	NE25.78357
16.....	NEO 2.5 Pedestal, Black.....	NE25.PED
17.....	Ash Dump Assembly	NE25.7857
18.....	Ash Drawer.....	NE25.78352
19.....	Air Shutter Assembly	NE16.7826
20.....	Secondary Air Control Assembly.....	NE16.7838
22.....	Levelling Feet (4pcs.)	NE16.5049765
23.....	Lower Grill Assy.....	NE25.5037903
24.....	Upper Grill	NE25.5037902
25.....	Removable back brick rail	NE25.78325
26.....	Heat Shield	NE25.7867
27.....	Pipe Shield(optional)	NE25.78725
28.....	Soapstone Hardware Pack.....	NE25.STHRDWR

*NOT SHOWN

All parts may be ordered from your nearest Pacific Energy dealer.
Contact Pacific Energy for the location of the dealer nearest you.

Understanding & Operating Your Pacific Energy Stove

The Pacific Energy SUPER SERIES line of woodstoves is a culmination of years of research and development. Designed to be efficient, clean-burning and user-friendly, this heater will give you years of warm service. However, a knowledgeable operator is still the most important factor for maximum performance and part of this is understanding the basic functions of this design.

Traditional wood stoves had a basic combustion system which allowed a considerable amount of heat energy to escape up the chimney as unburned gases and particulates (smoke). Pacific Energy has designed a system that solves the problem by burning the smoke and releasing the additional heat to the room.

This system has two critical design features:

1. Above fire secondary air injection:

The hollow "air baffle" injects super-heated secondary air just above the load. With the stove at the proper operating temperature, this will create a secondary flame that will be evident for approximately 1/3 of the total burn time.

2. High mass and thermal insulation:

The high mass (weight) acts as a heat storage and the thermal insulation keeps the combustion zone hot. Active flaming takes place during the first part of the burn. During this stage, heat is stored in the mass of the unit and is later released slowly and evenly. As wood chars, active flaming will diminish. This clean charcoal burning stage will last for a considerable length of time and refuelling should be avoided until the charcoal base has become quite small.

OPERATING TIPS

1. Always use dry, seasoned firewood, up to 18"(457mm) long.
2. Operate on a medium to high setting, for up to 1 hour from cold start. After the initial warm up period, refuel and leave the air control on a medium setting for 5 to 10 minutes more and then set the air control to the desired position.
3. If a slow burn is desired, set the air control to low. Active secondary burning should be present above the wood load. If it is not present or goes out shortly after, proper operating temperature has not been reached and the stove needs additional warm up time.



Firebrick Installation Instructions

NEO 2.5

This package contains 18 full-size firebricks, as well as 6 various cut-size bricks.

With the heater in the upright position, install firebricks as follows:

- Install the rear firebricks, 4 full-size, two on each side of the baffle tube.
- Then place 1 brick "B" in between the full bricks on the left as shown below.
- Next, install 4 full-size firebricks and brick "C" as shown on each side of the firebox.
- Lastly, place 5 full-size firebricks and 1 of each bricks B, C and 2 of D on the bottom of the heater in the pattern shown below.

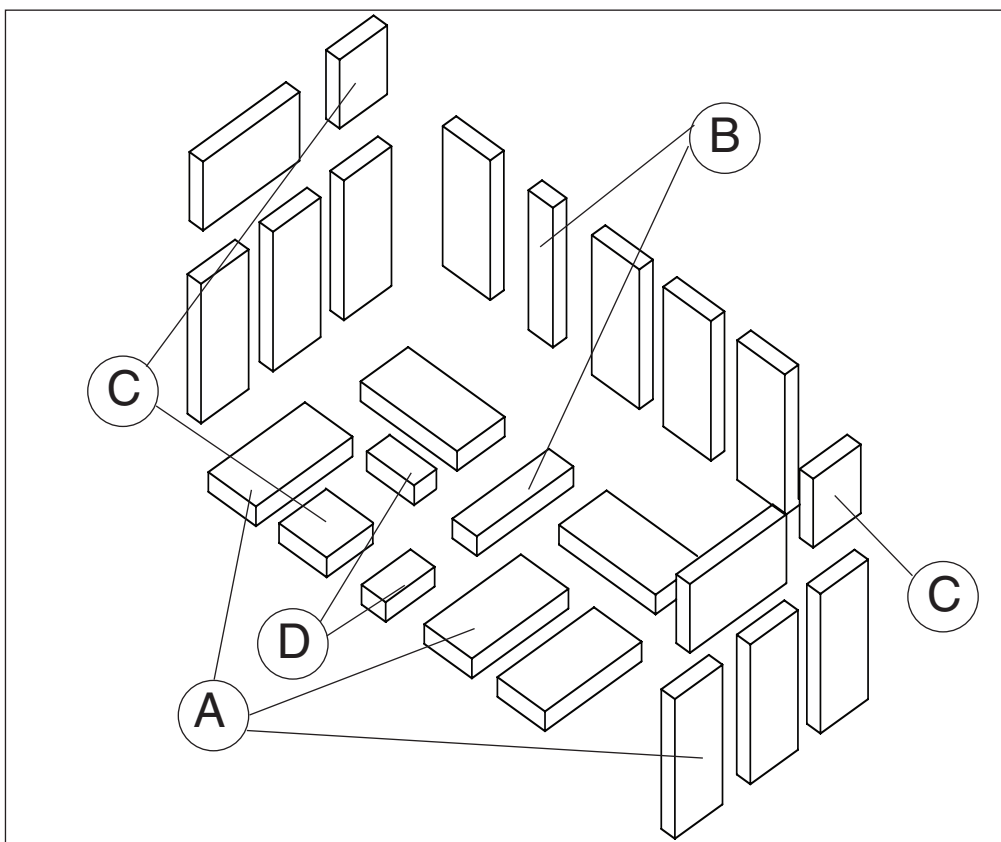

ITEM	DIMENSIONS		PART NUMBER
A	9" X 4 1/2" X 1 1/4"	(230 mm x 115 mm x 32 mm)	5096.99
B	2 1/8" X 9" X 1 1/4"	(57 mm x 230 mm x 32 mm)	7847.3
C	4 1/2" X 4 1/2" X 1 1/4"	(115 mm x 115 mm x 32 mm)	7847
D	2 1/8" X 4 1/2" X 1 1/4"	(57mm x 115 mm x 32 mm)	7847.1

Warranty Information

Pacific Energy Limited Lifetime Warranty Wood Products

Pacific Energy extends the following warranty coverage to the original registered purchaser of the product:

LTD Lifetime Coverage (10 years)

Limited lifetime coverage is extended to the following components (parts only) porcelain finish, glass (glass for thermal breakage only, not impact), plating, firebox and baffle.

3 Year Comprehensive

Pacific Energy will replace or repair any part found to be defective (parts and labor) for three years from the date of purchase.

This coverage includes electrical components (blowers, speed controls and thermal switches).

Conditions:

Your stove has been designed to perform in the harshest climates in North America. You can be confident that under normal use your stove will be trouble free for many years. If your stove is prematurely deteriorating this is a significant indicator of improper usage, for example; excessive draft, heating to large an area, contaminated fuel - such as high sodium content or plastics and chemicals. Please be aware, these conditions may be reasons to void your warranty.

For wood products - All installations must be installed according to all applicable local and national codes. It is the responsibility of the installer to ensure the unit is operating correctly at installation.

Any part that shows in our judgment evidence of defect shall be repaired, replaced or refunded at Pacific Energy's option. The defective part may be required to be returned to Pacific Energy or an accredited agent, transportation prepaid.

Porcelain is warranted for gloss retention. Certain colors may darken when heated and return to the original shade when cool.

Glass is warranted against thermal breakage.

Plating is warranted against tarnishing. Gold plating may attain a deeper color with use.

Exclusions

Limited Lifetime coverage - Lifetime coverage is limited to the repair, replacement or refund of the indicated parts only. Labor charges are not covered under the lifetime warranty.

The following items are not included in the Lifetime Warranty: firebox rails and heat shields.

The following parts are not warranted: firebrick, gaskets and ceramic fiber blankets.

This warranty does not apply to any part that shows evidence of misuse, abuse, improper installation, accident, lack of maintenance, or modification.

Pacific Energy shall in no event be liable for any special, indirect or consequential damages of any nature whatsoever which are in excess of the original purchase price of the product.

Pacific Energy is not responsible for installation, operational or environmental conditions beyond our control. (The company may, at its discretion, discharge all obligations by refunding the wholesale price of the defective part.)

For Warranty claims, please contact your nearest Pacific Energy dealer.





CERTIFIED FOR CANADA AND U.S.A. - SERIES / SÉRIE: A MODEL / MODÈLE: NEO 2.5 ■ NEWCASTLE 2.5 ■ NEOSTONE 2.5 ■
 LISTED ROOM HEATER, SOLID FUEL TYPE.
 ALSO FOR USE IN MOBILE HOMES
 TESTED TO / ÉPROUVÉ SELON: CANULC 5627-00 AND IN THE USA CONFORMS TO UL-1482-2011

InterTek
 ETL4001507

- INSTALL AND USE IN ACCORDANCE WITH THE MANUFACTURER'S INSTALLATION AND OPERATING INSTRUCTIONS.
- CONTACT LOCAL, BUILDING OR FIRE OFFICIALS ABOUT RESTRICTIONS, INSTALLATION PERMIT AND INSPECTION IN YOUR AREA.
- DO NOT CONNECT THIS UNIT TO A CHIMNEY FLUE SERVING ANOTHER APPLIANCE.
- USE 6 INCH / 150MM DIAMETER MINIMUM 24 MSG BLACK OR LISTED CONNECTOR.
- CAN BE CONNECTED TO A LISTED MASONRY CHIMNEY SUITABLE FOR USE WITH SOLID FUELS.
- SEE LOCAL BUILDING CODE AND MANUFACTURER'S INSTRUCTIONS FOR PRECAUTIONS REQUIRED WHEN PASSING A CHIMNEY THROUGH A COMBUSTIBLE WALL OR CEILING.
- MINIMUM CLEARANCE BETWEEN SINGLE WALL CHIMNEY CONNECTOR AND COMBUSTIBLE MATERIALS: 48/1200MM. CLEARANCE MAY BE REDUCED BY THE USE OF LISTED PIPE SHIELDS, WALL PROTECTORS OR OTHER MEANS APPROVED BY LOCAL, BUILDING OR FIRE OFFICIALS.
- COMPONENTS REQUIRED FOR MOBILE HOME AND ALCOVE INSTALLATION: OUTSIDE AIR KIT, BOTH CHIMNEY SYSTEM AND CONNECTOR MUST BE LISTED TO:
 IN CANADA - UL-C-S441 LISTED CONNECTOR AND UL-C-S-629 LISTED CHIMNEY
 IN USA - UL-703 HT LISTED CONNECTOR AND CHIMNEY
- USE COMPONENTS SPECIFIED IN PRACTICE ENERGY INSTALLATION INSTRUCTIONS.
- DO NOT ALLOW COMPONENTS TO BE EXPOSED TO OVERHEATING, FROM ELECTRICAL WIRING: 115V, 60HZ, 5 AMP.
- CAUTION: RISK OF EXCESSIVE TEMPERATURES - KEEP ASH DUMP CLOSED DURING FIRING OF THE HEATER.
- OPERATE ONLY WITH FEED DOOR CLOSED. OPEN TO FEED FIRE ONLY.
- KEEP FURNISHINGS AND OTHER COMBUSTIBLE MATERIALS WELL AWAY FROM HEATER.
- REPLACE GLASS ONLY WITH CERAMIC GLASS.
- HORIZONTAL CONNECTOR NOT PERMITTED IN MOBILE HOMES
- AS TESTED - PIPE SHIELD MAY BE REQUIRED BY LOCAL AUTHORITIES.
- COMBUSTIBLE ALCOVE SIZE: DEPTH - 3 FT. / 91 CM MAX., HEIGHT 7 FT. / 2.1 M MIN., WIDTH 43 IN. / 1.09 M MIN.
- COMBUSTIBLE FLOOR MUST BE PROTECTED BY A CONTINUOUS NON-COMBUSTIBLE MATERIAL EXTENDING TO THE FRONT, SIDES AND BACK AS INDICATED.
- OTHER MATERIALS MAY CAUSE DAMAGE TO STEEL OR HOME.
- HOT WHILE IN OPERATION. DO NOT TOUCH. KEEP CHILDREN, CLOTHING AND FURNITURE AWAY. CONTACT MAY CAUSE SKIN BURNS. SEE NAMEPLATE AND INSTRUCTIONS // CHAUD LORSQU'EN OPERATION. NE PAS TOUCHER, TENEZ LES ENFANTS ET LES VÊTEMENTS BIEN À L'ÉCART. LE CONTACT PEUT CAUSER DES BRÛLURES À LA PEAU. CONSULTEZ LA PLAQUE CE CONSTRUCTEUR ET LES INSTRUCTIONS.
- U.S. ENVIRONMENTAL PROTECTION AGENCY CERTIFIED TO COMPLY WITH JULY, 1990, PARTICULATE EMISSION STANDARDS/ CERTIFIÉ PAR L'AGENCE DE PROTECTION DE L'ENVIRONNEMENT DES ÉTATS-UNIS (EPA) EN ACCORD AVEC LES STANDARDS D'ÉMISSION DE PARTICULES DE JUILLET 1990

MINIMUM CLEARANCES TO COMBUSTIBLE MATERIALS / DÉGAGEMENTS MINIMAUX AUX MATÉRIAUX COMBUSTIBLES

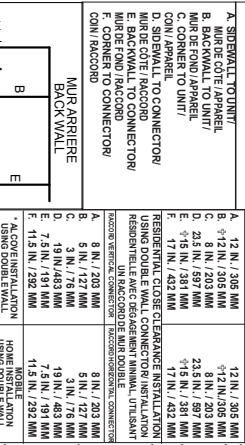

RESIDENTIAL INSTALLATION USING SINGLE WALL CONNECTOR / RACCORD DE MUR SIMPLE	MOBILE INSTALLATION / RACCORD DE MUR DOUBLE
A. 12 IN. / 305 MM	12 IN. / 305 MM
B. 12 IN. / 305 MM	12 IN. / 305 MM
C. 25 IN. / 635 MM	25 IN. / 635 MM
D. 25 IN. / 635 MM	25 IN. / 635 MM
E. 17 IN. / 432 MM	17 IN. / 432 MM
F. 17 IN. / 432 MM	17 IN. / 432 MM
RESIDENTIAL CLEARANCE INSTALLATION / DÉGAGEMENTS MINIMAUX ENTRE MATÉRIEL COMBUSTIBLE ET LE RACCORD DE MUR DOUBLE	
A. 8 IN. / 203 MM	8 IN. / 203 MM
B. 5 IN. / 127 MM	5 IN. / 127 MM
C. 3 IN. / 76 MM	3 IN. / 76 MM
D. 19 IN. / 483 MM	19 IN. / 483 MM
E. 11.5 IN. / 292 MM	11.5 IN. / 292 MM
F. 11.5 IN. / 292 MM	11.5 IN. / 292 MM
HOME INSTALLATION / RACCORD DE MUR DOUBLE	
A. 8 IN. / 203 MM	8 IN. / 203 MM
B. 5 IN. / 127 MM	5 IN. / 127 MM
C. 49 MM / 493 MM	49 MM / 493 MM
D. 75 MM / 191 MM	75 MM / 191 MM
E. 75 MM / 191 MM	75 MM / 191 MM
F. 11.5 IN. / 292 MM	11.5 IN. / 292 MM
IN CANADA	
G. 18 INCHES / 457 MM	18 INCHES / 457 MM
H. 8 INCHES / 200 MM	8 INCHES / 200 MM
I. 8 INCHES / 200 MM	8 INCHES / 200 MM
U.S.A.	
G. 16 INCHES / 405 MM	16 INCHES / 405 MM
H. 3.2 INCHES / 81 MM	3.2 INCHES / 81 MM
I. 0 INCHES / 0 MM	0 INCHES / 0 MM

MADE IN CANADA / FABRIQUÉ AU CANADA
 5650.900

DO NOT REMOVE THIS LABEL. SN-502

INSTALLER ET UTILISER SELON LES INSTRUCTIONS D'INSTALLATION ET D'OPERATION FOURNIES AVEC L'APPAREIL. CONTACTER LES OFFICIELS DE LA CONSTRUCTION OU DE SERVICE D'INCENDIE DANS VOTRE REGION. NE REBIER PAS C'EST APPAREIL A UN CONJUR DE CHEMINÉE DESSERVANT DEUX UN AUTRE APPAREIL. UTILISER UN TUYAU DE RACCORDEMENT DE 6 PO (150 MM) DIAM. HOMOLOGUÉ OU NON (24 MSG (MM)) POUR TRAVERSER LES MATÉRIELS COMBUSTIBLES. CONSULTER LE CODE LOCAL DE CONSTRUCTION ET LES INSTRUCTIONS DU FABRICANT QUANT AUX PRECAUTIONS A PRENDRE LORSQUE VOUS FAITES PASSER UNE CHEMINÉE A TRAVERSER UN MUR OU D'UN PLAFOND COMPOSÉS DE MATÉRIELS COMBUSTIBLES. LE TUYAU DE RACCORDEMENT DE CHEMINÉE NE DOIT PAS TRAVERSER UN MUR OU PLAFOND EN MATÉRIELS COMBUSTIBLES.

DÉGAGEMENT MINIMAL ENTRE LE RACCORDEMENT DE CHEMINÉE A SIMPLE PAROIS ET UN MUR ET TOUT MATÉRIEL COMBUSTIBLE - 18 POUCES / 457 mm. CE DÉGAGEMENT PEUT ÊTRE RÉDUIT EN UTILISANT DES PROTECTEURS DE TUYAUX CLASSES PROTECTEURS DE MUR OU AUTRES MOYENS APPROUVÉS PAR LES OFFICIELS DE LA CONSTRUCTION OU DU SERVICE D'INCENDIE DE VOTRE REGION. CONNECTEUR HORIZONTAL NON PERMIS DANS MAISONS MOBILES. PICES REQUISES POUR INSTALLATION EN MAISON MOBILE OU EN ALCOVE: PRISE D'AIR EXTÉRIEUR PATIÈRES SUIVANTS: EN COMBINAISON AVEC L'UN DES SYSTÈMES DE CHEMINÉE CANADA-TUYAU DE RACCORDEMENT HOMOLOGUÉ UL-C-441 ET CHEMINÉE HOMOLOGUÉE UL-C-629. ÉTATS-UNIS - TUYAU DE RACCORDEMENT ET CHEMINÉE HOMOLOGUÉS UL-103HT. COMPOSANTS OPTIONNELS: VENTILATEUR (MOOC, BLOW), ALIMENTATION ÉLECTRIQUE DU VENTILATEUR: 115 V, 60 HZ, 5 AMP. LE CORDON D'ALIMENTATION ÉLECTRIQUE NE DOIT PAS ÊTRE PLACÉ SOUS LE POÊLE. LE FIL ÉLECTRIQUE NE DOIT PAS ÊTRE PLACÉ SOUS LE POÊLE. ATTENTION: RISQUE DE TEMPÉRATURES EXCESSIVES - GARDER LE TIROR DE CENDRES FERMÉ PENDANT L'ALLUMAGE DU POÊLE.

OPÉREZ SEULEMENT LORSQUE LA PORTE D'ALIMENTATION EST FERMÉE. GARDEZ LES MÈCHES ET AUTRES MATÉRIELS COMBUSTIBLES BIEN ÉLOIGNÉS DU POÊLE. NE REBIER PAS C'EST APPAREIL A UN CONJUR DE CHEMINÉE DESSERVANT DEUX UN AUTRE APPAREIL. UTILISER UN TUYAU DE RACCORDEMENT DE 6 PO (150 MM) DIAM. HOMOLOGUÉ OU NON (24 MSG (MM)) POUR TRAVERSER LES MATÉRIELS COMBUSTIBLES. CONSULTER LE CODE LOCAL DE CONSTRUCTION ET LES INSTRUCTIONS DU FABRICANT QUANT AUX PRECAUTIONS A PRENDRE LORSQUE VOUS FAITES PASSER UNE CHEMINÉE A TRAVERSER UN MUR OU D'UN PLAFOND COMPOSÉS DE MATÉRIELS COMBUSTIBLES. LE TUYAU DE RACCORDEMENT DE CHEMINÉE NE DOIT PAS TRAVERSER UN MUR OU PLAFOND EN MATÉRIELS COMBUSTIBLES.

LE PLANCHER COMBUSTIBLE DOIT ÊTRE PROTÉGÉ PAR UN MATÉRIEL NON-COMBUSTIBLE TOUT D'UNE PIÈCE QUI DOIT S'ÉTENDRE DE DE L'AVANT, LES CÔTÉS ET L'ARRIÈRE TEL QU'INDIQUÉ. POUR UTILISER UN SOLANT THERMOISOLANT POUR LE POÊLE CONÇU POUR BRÛLER BOIS DE CORDE SEULEMENT, LA COMBUSTION D'AUTRES MATÉRIELS PEUT.

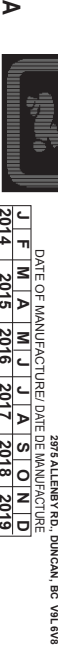

CAUTION

MANUFACTURED BY FABRIQUÉ PAR: PACIFIC ENERGY LTD. 2875 ALLENBY RD. DUNCAN, BC V9L 6V8
 DATE OF MANUFACTURE / DATE DE FABRICATION: J F M A M J J A S O N D 2014 2015 2016 2017 2018 2019

NE25-1





PACIFIC ENERGY FIREPLACE PRODUCTS LTD.

2975 Allenby Rd., Duncan, B.C. V9L 6V8

For technical support, please contact your retailer.

Web site: <http://www.pacificenergy.net>