



By Pacific Energy

# INSTALLATION & OPERATION GUIDE



SERIAL #
----------

## ALDERLEA T6 CAST IRON WOOD STOVE

**MODEL: ALDERLEA T6**  
 (STANDARD OR CLEARVIEW DOOR)  
**SERIES: B**

### SAFETY NOTICE

If this stove is not properly installed, a house fire may result. For your safety, follow the installation instructions. Contact local building or fire officials about restrictions and installation inspection requirements in your area.

**PLEASE SAVE THESE INSTRUCTIONS**



**TESTED and LISTED to**  
**CAN/ULC S627 AND UL 1482**  
**Meets the Environmental Protection Agency's**  
**May 2015 Particulate Emission Standards**



# Contents

<b>Contents</b> .....	<b>2</b>
<b>Safety and Maintenance</b> .....	<b>3</b>
<b>Maintenance Checks</b> .....	<b>4</b>
Chimney Smoke and Creosote Formation.....	5
Chimney Fires.....	5
Avoiding a Chimney Fire .....	5
<b>Appliance Dimensions</b> .....	<b>6</b>
<b>Outside Air Opening Dimensions</b> .....	<b>6</b>
If You Suspect a Chimney Fire .....	6
In Case of a Chimney Fire .....	6
<b>Installation – Residential</b> .....	<b>7</b>
Clearances – Residential.....	7
Minimum Clearances to Combustibles – Residential.....	7
Chimney and Connector – Residential .....	8
Double-Wall Connector – Residential .....	8
Single-Wall Connector – Residential .....	8
Installation Procedure – Residential .....	8
<b>Installation – Mobile Home</b> .....	<b>9</b>
Clearances – Mobile Home .....	9
Minimum Clearances to Combustibles – Mobile Home .....	9
Installation Procedure – Mobile Home .....	11
<b>Floor Protector</b> .....	<b>12</b>
<b>Combustion Air</b> .....	<b>12</b>
<b>Operation</b> .....	<b>13</b>
Wood Selection.....	13
How to Test Your Wood .....	13
Restarting After Extended or Overnight Burns.....	15
Heat Output Calculation .....	15
Proper Draft .....	15
Ash Removal .....	15
Disposal of Ashes .....	16
<b>Baffle Removal</b> .....	<b>16</b>
Removal.....	16
<b>Optional Blower</b> .....	<b>16</b>
Blower Operation.....	16
<b>Troubleshooting</b> .....	<b>17</b>
<b>Replacement Parts</b> .....	<b>18</b>
<b>Firebrick Installation Instructions</b> .....	<b>19</b>
<b>Warranty Information</b> .....	<b>20</b>
<b>Label</b> .....	<b>23</b>

## PLEASE SAVE THESE INSTRUCTIONS

This manual describes the installation and operation of the Alderlea, T6 Freestanding wood heater. This heater meets the 2015 U.S. Environmental Protection Agency's crib wood emission limits for wood heaters sold after May 15, 2015. Under specific test conditions this heater has been shown to deliver heat at rates ranging from 11,100 to 34,600 Btu/hr.

**NOTE: WE STRONGLY RECOMMEND THAT SMOKE AND CARBON MONOXIDE DETECTORS BE INSTALLED IN THE AREA WHERE THE HEATER IS TO BE INSTALLED.**

If smoke detectors have been previously installed, you may notice that they are operating more frequently. This may be due to curing of stove paint or fumes caused by accidentally leaving the fire door open. Do not disconnect the detectors.

**SAFETY NOTICE: If this stove is not properly installed, a house fire may result. For your safety, follow the installation instructions. Contact local building or fire officials about restrictions and installation inspection requirements in your area.**

Please read this entire manual before you install and use your new room heater. Failure to follow instructions may result in property damage, bodily injury, or even death.



# Safety and Maintenance

1. Burn only dry, well seasoned wood. The denser or heavier the wood when dry, the greater its heat value. This is why hardwoods are generally preferred. Green or wet wood should not be used, as it will reduce heat output, as well as contributing significantly to creosote buildup.
2. Remove ashes frequently and only when the stove is cold. Too much ash could cause embers to roll out the door when it is opened. This may pose a fire hazard. For proper operation, maintain a 1"(25mm) minimum ash base.
3. If glass becomes darkened from slow burning or poor wood, it can readily be cleaned with fireplace glass cleaner when stove is cold. Never scrape with an object or use abrasive cleaners that might scratch the glass. The type and amount of deposit on the glass is a good indication of the flue pipe and chimney buildup. A light brown dusty deposit that is easily wiped off usually indicates good combustion and dry, well-seasoned wood, therefore relatively clean pipes and chimney. On the other hand, a black greasy deposit that is difficult to remove is a result of wet and green wood and too slow a burning rate. This will also create heavy deposit buildup in the chimney.
4. DOOR GASKETS - The gasket used by Pacific Energy (5/16"(8mm) medium density fiberglass rope) requires only light pressure to seal. This will prolong seal life. It is important that the door seal be maintained in good condition. Periodically inspect seals and replace if necessary. Follow instructions included in the door gasket kit obtainable from your nearest Pacific Energy dealer.
5. DOOR GLASS - Do not slam loading door or otherwise impact glass. When closing door, make sure that no logs protrude to impact the glass. If the glass gets cracked or broken, **it must be replaced before using the stove.** Replacement glass can be obtained from your dealer. Use ceramic glass only. **Do not substitute with any other type.**

GLASS SIZE - 20.125"(511mm) x 11.875"(302mm) x 5mm

To remove broken glass, undo the four retaining screws and remove clamps, noting position for re-assembly. Remove all particles of glass. Be careful as they are very sharp. Install new glass complete with gasket. Replace clamps and screws.

6. Do not store wood within heater installation clearances, or within the space required for fuel loading and ash removal. Keep the area around the heater clean and free of loose combustibles, furniture, newspapers, etc.
7. If the heater requires cleaning, use mild soap and water only. **Use of abrasive cleaners will void warranty.**
8. Establish a routine for fuelling and firing the heater. Check daily for creosote buildup until experience shows how often you need to clean the chimney to be safe.
9. Be aware that the hotter the fire, the less creosote is deposited. Weekly cleaning may be necessary in mild weather, even though monthly cleaning is usually enough in the coldest months when burning rates are higher.
10. Instruct all members of your family on the safe operation of the heater. Ensure they have enough knowledge of the entire system if they are expected to operate it. Study the section on chimney fires and the importance of following the steps outlined "In Case of Chimney Fire".

## WARNING:

**Never use chemicals or any other volatile liquid to start a fire. Do not burn garbage, or flammable fluids such as gasoline, naphtha, or engine oil. We strongly recommend that smoke detectors be installed.**

## WARNING:

**Only use materials and components supplied or specified by manufacturer when doing maintenance or replacements.**

## CAUTION:

- do not overtighten, tighten screws very carefully
- do not clean glass when hot
- do not use abrasive cleaners on glass

NATIONAL  
FIREPLACE  
INSTITUTE



CERTIFIED

We recommend that our woodburning hearth products be installed and serviced by professionals who are certified in the U.S. by the National Fireplace Institute® (NFI) as NFI woodburning Specialists or who are certified in Canada by Wood Energy Technical Training (WETT).



Wood Energy  
Technical Training

---

## Maintenance Checks

Check the following parts for damage such as cracks, excessive corrosion, burned out sections and excessive warping: (See website for descriptions and more detail)

### Weekly:

- Firebrick - Visual, for cracking.
- Door Gasket - sagging, placement, damage.

### Monthly

- Brick rail tabs and brick rails.
- Air riser tube in the back of the firebox.
- Back side of airwash chamber.
- Baffle locking pin.
- Boost tube cover.

### When Cleaning the Chimney System:

- Top baffle board/blanket.
- Baffle.
- Top heat shield and mounting bolt.
- Baffle Gasket.
- Brick Rails.
- Manifold.

### Blower:

- The blower should be cleaned out a minimum every six months by using a vacuum on the grill openings in the back and bottom of the blower casing to remove any dust and debris.
- Some warping of the baffle is normal(up to 1/4" or .65cm).
- Replace if the baffle has permanent warping greater than this or has cracking or breakage.
- Please contact your Dealer if you experience any of the damage listed above. Continuing to operate your stove with broken parts may accelerate damage to other parts and may void your warranty



---

## Chimney Smoke and Creosote Formation

When wood is burned slowly, it produces tar and other organic vapours, which combine with expelled moisture to form creosote. The creosote vapours condense in the relatively cool chimney flue of a slow burning fire. As a result, creosote residue accumulates on the flue lining. When ignited, this creosote makes an extremely hot fire. The chimney connector and chimney should be inspected periodically (at least once every two months) during the heating season to determine if a creosote buildup has occurred. If creosote has accumulated (3 mm. or more), it should be removed to reduce the risk of a chimney fire.

1. Highest smoke densities and emissions occur when a large amount of wood is added to a bed of hot coals and the air inlet is closed. The heated wood generates smoke, but without ample air, the smoke cannot burn. Smoke-free, clean burning requires small fuel loads, two or three logs at a time or 1/4 to 1/2 of fuel load and leaving the air inlet relatively wide open, especially during the first 10 to 30 minutes after each loading, when most of the smoke generating reactions are occurring. After 30 minutes or so, the air inlet can be turned down substantially without excessive smoke generation. Wood coals create very little creosote-producing smoke.
2. The cooler the surface over which the wood smoke is passing, the more creosote will be condensed. Wet or green wood contributes significantly to creosote formation as the excess moisture that is boiled off cools the fire, making it difficult for the tars and gases to ignite, thus creating dense smoke and poor combustion. This moisture-laden smoke cools the chimney, compounding the problem by offering the smoke the ideal place to condense.  
In summary, a certain amount of creosote is inevitable and must be lived with. Regular inspection and cleaning is the solution. The use of dry, seasoned wood and ample combustion air will help to minimize annoying smoke emissions and creosote buildup.

## Chimney Fires

Excessive creosote build-up can cause a chimney fire. Creosote comes from tar and organic vapours released from a slow burning wood fire. Flammable creosote will condense and accumulate in the lining of a relatively cool chimney. When ignited, this creosote can result in an extremely hot fire.

## Avoiding a Chimney Fire

There are two ways to avoid chimney fires:

1. Keep your chimney clear of creosote build-up by cleaning your chimney before each burn season, and as necessary (accumulations of 3 mm/1/8" or more) during the season.
2. Burn clean, well-seasoned wood only (seasoned at least one year). Avoid wet or green wood.
3. Do not burn household trash, cardboard, plastics, construction lumber, treated or beach wood (salt from beach wood will corrode your fireplace and void your warranty).
4. Do not leave the air inlet wide-open for extended periods of time.
5. Keep a fire extinguisher handy.
6. Prepare a home evacuation plan with a place outside where everyone is to meet.

## If You Suspect a Chimney Fire

Signs of a chimney fire may be one or more of the following:

1. A roaring sound
2. Vibration of the chimney
3. Flames and sparks shooting out of the top of the chimney

## In Case of a Chimney Fire

1. Immediately close the air inlets on the stove.
2. Evacuate the home, and call the local fire department.
3. After the chimney fire has been extinguished, the chimney must be cleaned and checked for stress and cracking before starting another fire. Also check combustibles around the chimney and roof.

We recommend that our woodburning hearth products be installed and serviced by professionals who are certified in the U.S. by the National Fireplace Institute® (NFI) as NFI woodburning Specialists or who are certified in Canada by Wood Energy Technical Training (WETT).

## Appliance Dimensions

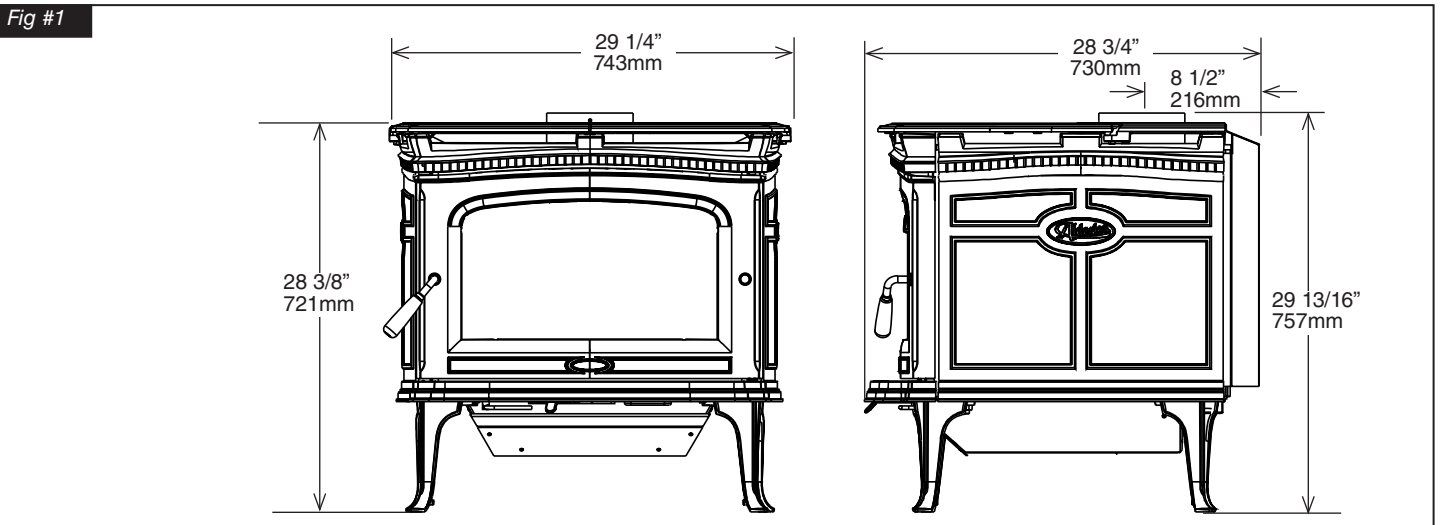

## Outside Air Opening Dimensions

Fig #1a

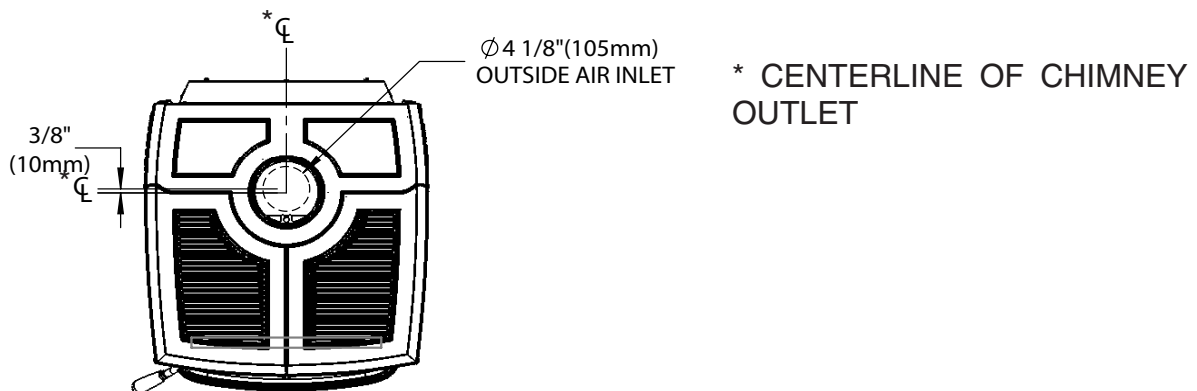

# Installation – Residential

**Warning:**

Under no circumstances is this heater to be installed in a makeshift or "temporary" manner. It may be fired only after the stove is installed properly.

- DO NOT ATTEMPT TO CONNECT THIS HEATER TO ANY AIR DISTRIBUTION DUCT.
- We recommend that our woodburning hearth products be installed and serviced by professionals who are certified in the U.S. by the National Fireplace Institute® (NFI) as NFI woodburning Specialists or who are certified in Canada by Wood Energy Technical Training (WETT).
- Outside combustion air or fresh air into the room may be required in your area, consult local building codes (see Combustion Air section).

Do not connect this unit to a chimney flue serving another appliance.

**BOTH CHIMNEY SYSTEM AND CONNECTOR MUST BE LISTED TO: IN CANADA - ULC S-641 LISTED CONNECTOR AND ULC-S-629 LISTED CHIMNEY, IN USA - UL-103 HT LISTED CONNECTOR AND CHIMNEY**

## Clearances – Residential

1. This heater may be installed using a single-wall connector (smoke pipe) or listed double-wall connector (see Mobile Home installation).
2. Clearances to combustible surfaces and materials using single-wall connector are shown in Figure #2.

Clearances may be reduced with various heat insulating materials. Consult local, National fire codes and authorities for approval.

3. Alternately, for close clearances, use a listed double-wall connector. See Figure #2a.

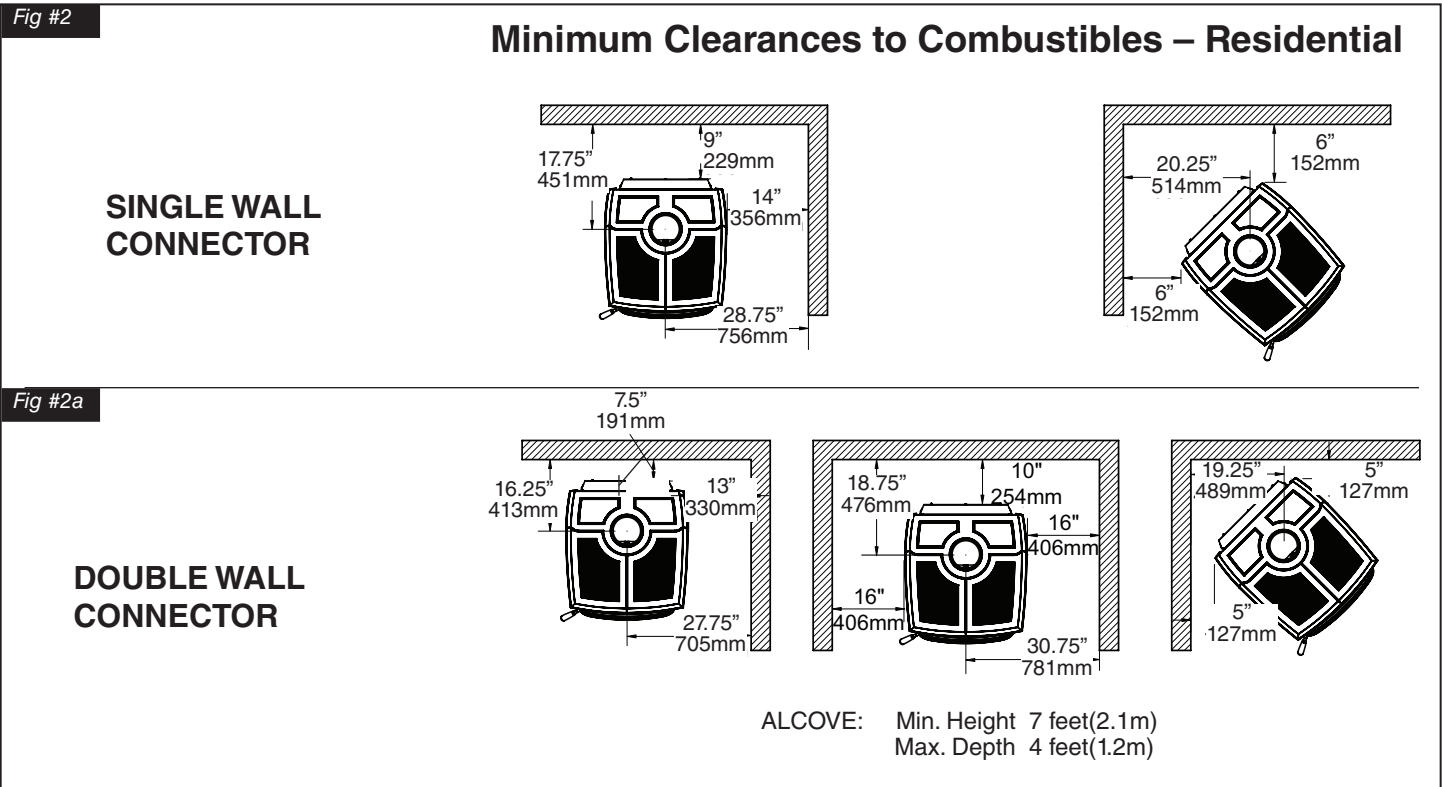



---

## Chimney and Connector – Residential

Connect to a listed chimney (in the U.S.A. a chimney complying with the requirements for Type HT chimneys in the standard for Chimneys, Factory-Built, Residential Type and Building Heating Appliance, UL 103) and a chimney suitable for use with solid fuel that is lined and in good condition and meets local building codes. The chimney flue size should be the same as the stove outlet for optimal performance. Reducing or increasing the flue size may adversely affect stove performance. Chimney flue exit is to be 3 feet (1 m) above roof and two feet (0.6 m) above highest projection within 10 feet (3 m). The installation must meet all local codes. Do not connect this unit to a chimney flue serving another appliance. Minimum system height is 15 feet (4.6 m) (measured from base of appliance).

## Double-Wall Connector – Residential

- Use a listed double-wall connector suitable for solid fuel.
- Install all components to the chimney connector manufacturer's installation requirements.

## Single-Wall Connector – Residential

Smoke pipe must be:

- As short and straight as possible, use six inch diameter, 24 gauge black pipe that is clean and in new condition.
- Secured at every joint and collar with 3 sheet metal screws.
- Installed with the crimped or male ends pointing down. This will carry any liquid creosote or condensation back into the stove.
- The chimney connector shall not pass through an attic, roof space, closet or similar concealed space, floor, or ceiling. Where passage through a wall, or partition of combustible material is desired, the installation shall conform to CAN/CSA-B365, Installation Code for Solid-Fuel-Burning Appliances and Equipment.

## Installation Procedure – Residential

1. If a listed chimney and double-wall connector is to be connected to the stove, install all components to the chimney manufacturer's installation requirements. (Outside combustion air may be required, consult local building codes. See Combustion Air section on page 11.)
2. If it is desirable to use smoke pipe in conjunction with the insulated chimney, see step 4.
3. If a roof or ceiling support is used in the installation, you will find the chimney manufacturer's complete instructions packed with the roof support.
4. To start installing smoke pipe (chimney connector), slip crimped edge of the pipe inside the stove collar. Use holes provided in collar to secure pipe with three screws.
5. Install the remaining lengths of pipe, one on top of the other, to the finished height of the chimney connector and secure to each other.





# Installation – Mobile Home

## Warning:

Under no circumstances is this heater to be installed in a makeshift or "temporary" manner. It may be fired only after the following conditions have been met.

- **DO NOT CONNECT THIS UNIT TO A CHIMNEY FLUE SERVING ANOTHER APPLIANCE.**
- **DO NOT INSTALL IN A SLEEPING ROOM.**

Outside air supply must be used for Mobile Home installations (see Figure #4, Page 10).

We recommend that our woodburning hearth products be installed and serviced by professionals who are certified in the U.S. by the National Fireplace Institute® (NFI) as NFI woodburning Specialists or who are certified in Canada by Wood Energy Technical Training (WETT).

**BOTH CHIMNEY SYSTEM AND CONNECTOR MUST BE LISTED TO: IN CANADA - ULC S-641 LISTED CONNECTOR AND ULC-S-629 LISTED CHIMNEY, IN USA - UL-103 HT LISTED CONNECTOR AND CHIMNEY**

## CAUTION:

The structural integrity of the mobile home floor, wall, and ceiling/roof must be maintained.

## Clearances – Mobile Home

This heater must be installed with listed double-wall connector and compatible chimney system listed on page 10.

Clearances to combustible surfaces and materials are shown below in Figures #3.

Clearances may be reduced with various heat insulating materials. Consult local, National fire codes and authorities for approval.

**NOTE:** Longer chimney lengths and different pitch flashings may be used. All other parts listed must be installed (see Page 10). Install all components to the connector or chimney manufacturer's installation requirements. Consult your chimney supplier for installation advice.

Fig #3

## Minimum Clearances to Combustibles – Mobile Home

### DOUBLE WALL CONNECTOR

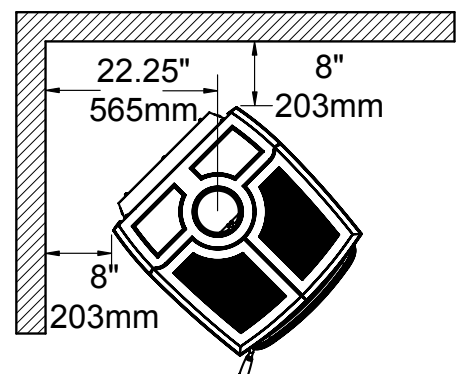
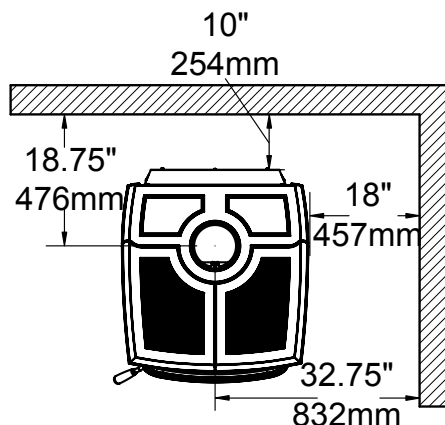
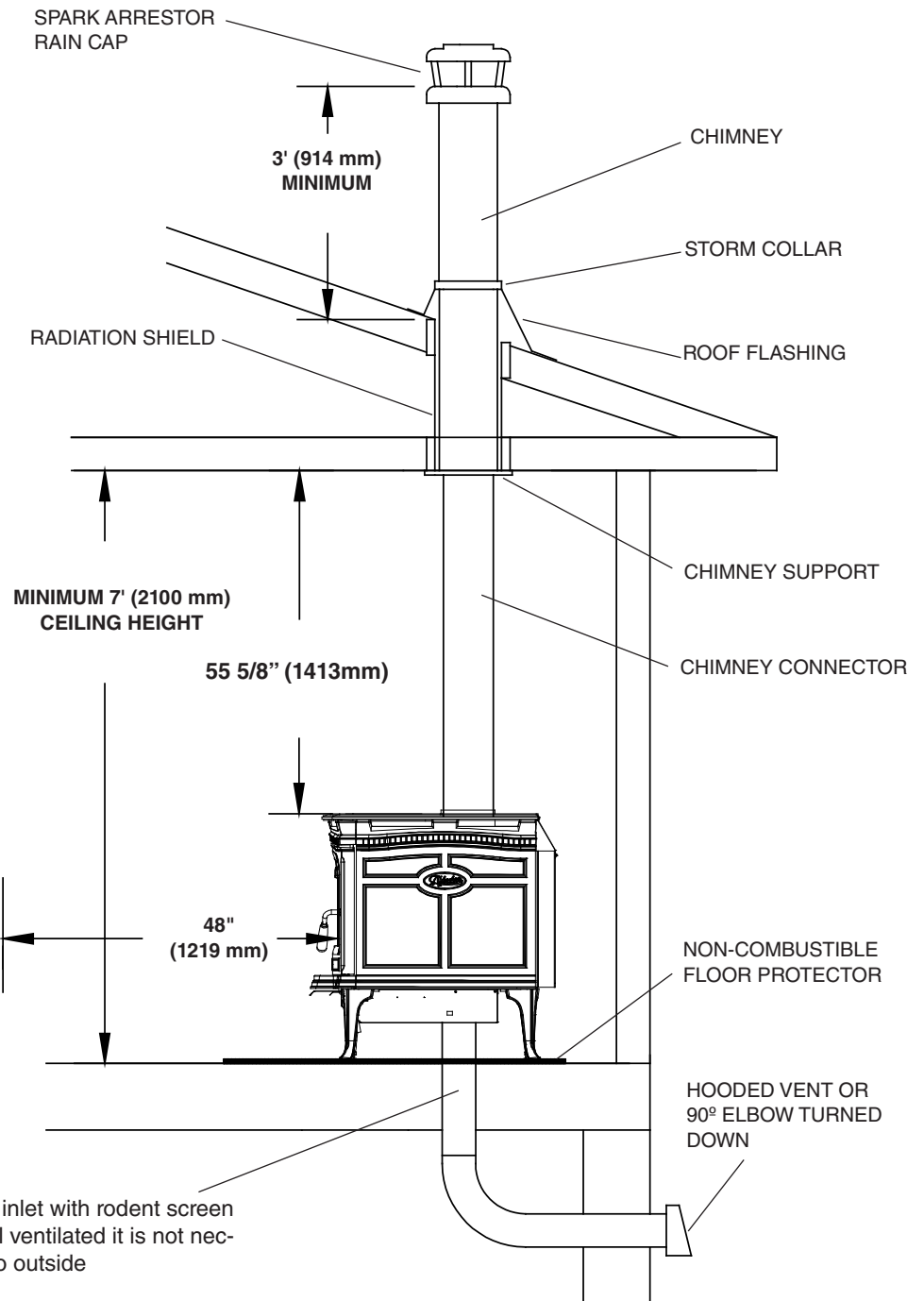

Fig #4



The chimney may incorporate an offset. To do this safely, all sections of listed connector, offset elbows and chimney section must be screwed together by at least three sheet metal screws per joint. The chimney must be suitably supported by the chimney manufacturer's listed offset support.

- \* 4" (100mm) diameter air inlet with rodent screen
- \* If the crawl space is well ventilated it is not necessary to extend air inlet to outside

---

## Installation Procedure – Mobile Home

**CAUTION: THE STRUCTURAL INTEGRITY OF THE MOBILE HOME FLOOR, WALL AND CEILING/ROOF MUST BE MAINTAINED.**

**BOTH CHIMNEY SYSTEM AND CONNECTOR MUST BE LISTED TO: IN CANADA - ULC S-641 LISTED CONNECTOR AND ULC-S-629 LISTED CHIMNEY, IN USA - UL-103 HT LISTED CONNECTOR AND CHIMNEY**

Note: See "Combustion Air" section on page 12.

1. Position stove and floor protection with hole for combustion air in accordance with the clearances as stated on the label and in Figures #3.
2. Mark the position for the hole in the ceiling and roof by using a string and plumb-bob.
3. Check that the intended location will not interfere with floor joists, ceiling joists or rafters before proceeding further.
4. Cut a hole in the ceiling and roof to suit the chimney system and frame in the sides. The chimney support is mounted to the framing.
5. Assemble chimney sections so the finished length is resting on the support and protruding through the roof. Avoid having joints between ceiling and roof. Install radiation shield. Assemble flashing and storm collar and be sure to maintain the vapour barrier at this point. (Seal securely.) Attach rain cap and check flashing for leaks.
5. Install connector as per manufacturer's instructions.
6. To attach stove to floor, first remove the leveling bolts from the legs. Then attach stove to flooring using two 1/4" x 2" or longer lag screws through the leveling bolt holes.

Follow chimney and chimney components manufacturer's instruction for assembly and installation.

## Floor Protector

Fig #5

### Canada Only

Minimum Width - 43"(1.09m)

Minimum Overall Depth - 50 1/2(1.28m)

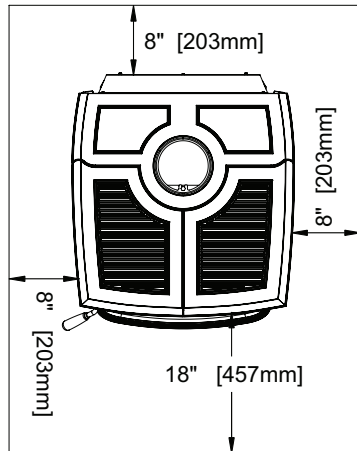

Non-combustible floor protector

The stove may be installed on a combustible floor provided noncombustible ember protection is used.

This protection must extend as follows:

In Canada: 18" (457 mm) on the firing side and 8" (203 mm) to the other sides. See Figure #5 on left.

In USA: 16" (406 mm) to the front and 8" (203 mm) to the sides of the fuel loading door opening. See Figure #6 on right. This protection is also required under the chimney connector and 2" (51 mm) beyond each side.

Fig #6

### U.S.A. Only

Minimum Width - 36"(914mm)

Minimum Overall Depth - 40 1/2 (1.03m)

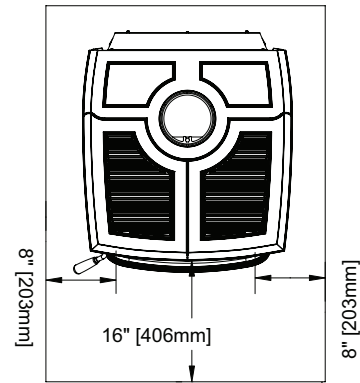

Non-combustible floor protector

## Combustion Air

Intake or combustion air can be supplied to the stove in one of two ways. Consult your local building code or CAN/CSA-B365, Installation Code for Solid-Fuel-Burning Appliances and Equipment before proceeding.

1. **Outside air supply** - (Necessary for mobile home installation, optional for residential installation.) To draw outside air through the floor, cut or drill a 4"(100mm) diameter hole directly below the bottom hole of the ash box enclosure(see page 6 Fig. #1a). Connect enclosure to the floor with a short 4"(100mm) diameter pipe.

This hole must get its air from a **ventilated** crawl space or be extended with duct to the outdoors (see Figure #4, Page 10). The use of outside combustion air for residential installation requires the unit to be secured to the structure to prevent dislodging of the air duct.

**Note:** When installed in a mobile home, this unit is not designed to be operated with the firing door open. In addition to the obvious hazard of sparks landing on combustibles, an open fire door will cause the heater to draw air from the living space and possibly cause suffocation.

2. **Room air supply** -There is a 4"(100mm) opening in the ash box enclosure. The stove will draw its air from the room through this opening and into the firebox intake.

**Note:** The living space around the heater must be well ventilated with good air circulation. Anything that may cause a negative pressure can cause gases or fumes to be pulled into the living area. During extremely cold weather, and especially when burning at very slow rates, the upper parts of the exposed chimney may ice up, partially blocking the flue gases. If blockage occurs, flue gases may enter living space.

---

## Operation

### CAUTION:

Never use gasoline, gasoline type lantern fuel, kerosene, charcoal lighter fluid or similar liquids to start or "freshen up" a fire in this heater. Keep all such liquids well away from the heater while it is in use.

### CAUTION:

**Hot while in operation. Keep children, clothing and furniture away. Contact may cause skin burns.**

Your PACIFIC ENERGY heater is designed for maximum overall efficiency at a moderate firing rate. Overfiring is hazardous and a waste of fuel. Too slow a burn contributes to creosote buildup and lowers combustion efficiency.

## Wood Selection

This heater is designed to burn natural wood only. Higher efficiency and lower emissions generally result when burning air-dried seasoned hardwoods, as compared to softwoods or too green or freshly cut hardwoods.

Wood should be properly air dried (seasoned) for six months or more. Wet or undried wood will cause the fire to smoulder and produce large amounts of creosote. Wet wood also produces very little heat and tends to go out often.

### DO NOT BURN :

- Salt water wood \*
- Wet or green wood
- Garbage\*
- Lawn clippings/yard waste
- Railroad ties
- Materials containing rubber, including tires
- Materials containing plastic
- Waste petroleum products, paints or paint thinners, or asphalt products
- Materials containing asbestos
- Construction or demolition debris
- Paper products, cardboard, plywood, or particleboard.
- Treated wood
- Coal/charcoal
- Solvents
- Unseasoned wood
- Manure or animal remains

**\* These materials contain chlorides which will rapidly destroy metal surfaces and void warranty.**

Burning these materials may result in the release of toxic fumes or render the heater ineffective and cause smoke.

The prohibition against burning these materials does not prohibit the use of fire starters made from paper, cardboard, saw dust, wax and similar substances for the purpose of starting a fire in an affected wood heater.

Do not burn anything but wood. Other fuels (eg. charcoal) can produce large amounts of carbon monoxide, a tasteless, odourless gas that can kill. Under no circumstances should you attempt to barbecue in this heater.

## How to Test Your Wood

Add a large piece of wood to the stove when it has a good large bed of coals. It is dry if it is burning on more than one side within one minute. It is damp if it turns black and lights within three minutes. If it sizzles, hisses and blackens without igniting in five minutes it is soaked and should not be burnt.

---

## Lighting a Fire

**WARNING: Never use chemicals or any other volatile liquid to start a fire.**

1. Adjust air control to “High” position(all the way to the left) and open door.
2. Place crumpled newspaper in the centre of the heater and criss-cross with several pieces of dry kindling. Add a few small pieces of dry wood on top.
3. Ignite the paper and leave the door ajar approximately 1/2”(13mm) - 1”(25mm) until the wood kindling is fully engulfed in flame.
4. After the kindling is fully engulfed add a few small logs. Close door.
5. Begin normal operation after a good coal base exists and wood has charred.

## Curing of the Paint Finish

When burning your stove for the first 2-3 times it is very important that the room be well ventilated. Open all windows and doors. Smoke and fumes caused by the curing process may cause discomfort to some individuals.

## Normal Operation

**WARNING: This wood heater has a manufacturer-set minimum low burn rate that must not be altered. It is against federal regulations to alter this setting or otherwise operate this wood heater in a manner inconsistent with the operating instructions in this manual.**

1. Set air control to a desired setting. If smoke pours down across the glass (waterfall effect) this indicates you have shut the control down too soon or you are using too low a setting. As every home's heating needs vary (based on insulation, windows, climate, etc.) the proper setting can only be found by trial and error and should be noted for future burns.
2. To refuel, adjust air control to high, and give the fire time to brighten. Open the door slowly, this will prevent backpuffing.
3. Use wood of different shape, diameter and length (up to 20”(508mm)). Load your wood endwise and try to place the logs so that the air can flow between them. Always use dry wood.
4. Do not load fuel to a height or in such a manner that would be hazardous when opening the door.
5. For extended or overnight burns, unsplit logs are preferred. Remember to char the wood completely on maximum setting before adjusting air control for overnight burn.

**WARNING: Always keep loading door closed when burning. This heater is not designed for open door burning.**

**WARNING: No alteration or modification of the combustion air control assembly is permitted. Any tampering will void warranty and could be very hazardous.**

**WARNING: Do not use grates or andirons to elevate the fuel. Burn directly on the fire bricks. Replace broken or missing bricks. Failure to do so may create a hazardous condition.**



---

## Restarting After Extended or Overnight Burns

1. Open door and rake hot embers towards the front of the heater. Add a couple of dry, split logs on top of embers, close door.
2. Adjust air control to high (left position) and in just a few minutes, logs should begin burning.
3. After wood has charred, reset air control to desired setting.
4. To achieve maximum firing rate, set control to high (left position). Do not use this setting other than for starting or preheating fresh fuel loads.

**DO NOT OVERFIRE THIS HEATER:**  
Attempts to achieve heat output rates that exceed heater design specifications can result in permanent damage to the heater and chimney.

## Heat Output Calculation

Seasoned wood has approximately 7500 BTU's per pound.

The calculation is as follows:

$$\frac{\text{Amount of wood in lbs. X 7500BTU's}}{\text{Burn rate in Hrs.}} \times .8(80\% \text{ Avg. Efficiency})$$

Experience will give you the right settings for proper combustion and efficient burning. Remember the correct air inlet setting is affected by variables such as type of wood, outside temperature, chimney size and weather conditions. With practice, you will become proficient in operating your heater and will obtain the performance for which it was designed.

## Proper Draft

1. Draft is the force which moves air from the appliance up through the chimney. The amount of draft in your chimney depends on the length of the chimney, local geography, nearby obstructions and other factors.
2. Too much draft may cause excessive temperatures in the appliance. An uncontrollable burn or a glowing red stove part or chimney indicates excessive draft.
3. Inadequate draft may cause backpuffing into the room and plugging of the chimney. Smoke leaking into the room through appliance and chimney connector joints indicates inadequate draft.

## Ash Removal

Whenever ashes get 3(76mm) to 4(102mm) inches deep in your firebox, and when fire has burned down and cooled, remove excess ashes. Leave an ash bed approximately 1" (25 mm) deep on the firebox bottom to help maintain a hot charcoal bed.

**Ash Chute Operation:** Your Alderlea stove is equipped with an ash chute system to ease removal of ash from the ash lip area. To use this system, first pull out the ash pan approximately 2"(51mm), sweep the ash into the chute located to the right side of the ash lip, and close the ash pan.

**Ash Cleanout System:** The ash dump handle is located under the ash lip on the left hand side. To operate ash dump, pull handle out 1/2"(12mm) and turn clockwise. This will unlock the ash dump and allow it to open. Hold handle open while pulling ashes into the opening. Avoid large embers as these still contain heat value. Release handle and push in to lock. Ensure ash dump door is properly engaged. Fill the cavity with the remaining ash level with the firebox floor. Pull out ashpan and discard ashes into metal container. Replace ashpan and ensure it is seated properly.

**CAUTION:**  
Ashes are to be removed only when the heater is cold.

**Do not burn with ash dump door open. Doing so will create a hazardous condition. Always leave about 1"(25mm) of ash when cleaning.**



---

## Disposal of Ashes

Ashes should be placed in a metal container with a tight fitting lid. The closed container of ashes should be placed outside on a non-combustible floor or on the ground, well away from all combustible materials, pending final disposal. If the ashes are disposed of by burial in soil or otherwise locally dispersed, they should be retained in a closed container until all cinders have thoroughly cooled. Other waste should not be placed in this container.

## Baffle Removal

Chimney connector pipe should be disconnected from stove to clean and inspect. Only if this is not possible should you remove baffle assembly.

**DO NOT OPERATE WITH BAFFLE ASSEMBLY OR INSULATION REMOVED.**

### Removal

Remove retaining pin located at the rear top of the firebox, just below the baffle. Lift baffle up and pull forward to disconnect from the supply tube. Tilt baffle sideways to drop down and remove from firebox. Inspect gasket between baffle and supply tube. If necessary, replace with gasket #3139.5 available from your Pacific Energy dealer. Re-install baffle assembly in reverse order. The two side pieces of insulation must be tight against the siderails.

### Secondary Air Box Removal and Cleaning:

1. The secondary air box is located on the bottom rear of the woodstove and can be cleaned by removing the two screws securing the cover plate on the rear face of the secondary air box and using a vacuum to suck out any debris.
2. To remove the secondary air box, use a 3/8" wrench and undo the two #10 Keps nuts, one on each side of the secondary air box. Lower the secondary air box and slide out.
3. Reverse this process to re-install the secondary air box.

\* **MAKE SURE THE GASKET IS IN GOOD SHAPE AND POSITIONED CORRECTLY.**

## Optional Blower

The optional blower kit (kit #WODC.BLOW) is equipped with a three prong power cord and may be installed at any time. Follow installation instructions supplied with the kit. Route power supply cord away from heater.

Electrical rating: 115 volts A.C.- 0.84 amps.

Fan output rating: 140 CFM

### Blower Operation

Proper blower speed matched with air control setting will ensure peak performance from your stove. Operate as follows:

- Air control set to low (right position), operate blower speed control on "Low".
- Air control set between low and high (middle position), operate blower speed control at desired setting.

**Automatic:** To operate the blower automatically, set the rocker switch on the side of the fan housing to "Auto" and set the speed control to desired setting. This will allow the fan to turn on as the stove heats up to operating temperature. It will also shut the blower off after the fire has gone out and the unit cooled to below a useful heat output range.

**Manual:** To manually operate the blower, set the rocker switch to "Man" and set the speed control to desired setting. This will bypass the sensing device and allow full control of the blower.

Switching from "Auto" to "Man" or selecting speed may be done anytime.



# APPENDIX A

## Troubleshooting

Problem	Cause	Cure
Glass is Dirty	<ol style="list-style-type: none"> <li>1. Wood is wet</li> <li>2. Turning down air control or damper too soon</li> <li>3. Draft too low</li> <li>4. Door gasket leakage</li> </ol>	<ul style="list-style-type: none"> <li>• Use dry wood</li> <li>• Do not turn down until               <ol style="list-style-type: none"> <li>a) there is a good bed of coals</li> <li>b) the wood is charred</li> </ol> </li> <li>• Improper chimney height and / or diameter, -consult dealer</li> <li>• Chimney plugged or restricted, - inspect and clean</li> <li>• Provide outside air for combustion</li> <li>• Replace gasket</li> <li>• Check latch for proper operation</li> </ul>
Excessive Creosote Buildup	See 1,2,3, above.	See 1,2,3, above.
Low Heat Output	<ol style="list-style-type: none"> <li>1. Wood is wet</li> <li>2. Fire too small</li> <li>3. Draft too low</li> </ol>	<ul style="list-style-type: none"> <li>• Use dry wood</li> <li>• Build a larger fire</li> <li>• Chimney plugged or restricted, - inspect and clean</li> </ul>
Won't Burn Overnight	<ol style="list-style-type: none"> <li>1. Air control is set too high</li> <li>2. Not enough wood</li> <li>3. Draft too high</li> <li>4. Poor quality or wet wood</li> </ol>	<ul style="list-style-type: none"> <li>• Set air control lower</li> <li>• Unsplit wood is preferred for overnight burns</li> <li>• Excessive chimney height and/or diameter</li> <li>• Use good quality, dry wood</li> </ul>
Wood Won't Burn	<ol style="list-style-type: none"> <li>1. Combustion air supply blocked</li> <li>2. Draft too low</li> </ol>	<ul style="list-style-type: none"> <li>• Check outside air supply for obstruction</li> <li>• Chimney plugged or restricted, - inspect and clean</li> <li>• Chimney oversized or otherwise unsuitable, -consult Dealer</li> </ul>

# Replacement Parts

#1 BAFFLE KIT .....	SUMB.BAFKIT	#11 DOOR CATCH .....	4835
#2 BRICK RAILS (2).....	SUMM.RAILSET	#12 DOOR CROWN BLACK PAINT .....	ALT6.4802MBK
#3 FLAME SHIELD .....	SUMB.31155	#13 ASHLIP BLACK PAINT .....	ALT6.4801MBK
#4 DOOR ASSEMBLY LEFT .....	ALT6.4800LMBK	#14 LEG ADAPTER .....	AL6B.LGADA
...RIGHT .....	ALT6.4800RMBK	#15 ASH PAN ASSY. ....	4825
CLEARVIEW DOOR ASSY .....		#16 FAN (OPTIONAL).....	WODC.BLOW
...BLACK PAINT .....	R - ALT6.4811RMBK	#17 DOOR STOP (LHS).....	ALT6.4830MBK
...BLACK PAINT .....	L - ALT6.4811LMBK	#18 AIR SHUTTER ASSEMBLY .....	FSND.4631
#4a DOOR HANDLE.....	ALDR.50380GL	#19 AIR DEFLECTOR.....	4815.5
.....	ALDR.50380GR	#20 SECONDARY AIR BOX GASKET .....	5068.3237
#4d DOOR GASKET KIT.....	4880	#21 SECONDARY AIR BOX .....	SUMB.3140
#4e GLASS C/W GASKET .....	2080.9		
#4f GLASS CLAMPS.....	4720.01		
#5 FIREBRICK SET .....	BRIC.SUMMA		
#6 SIDE CASTING MBK (2) .....	ALT6.4805MBK		
#7 TOP GRILL ASSEMBLY (3) .....	ALT6.TGASSYMBK		
#8 ASH DUMP ASSEMBLY .....	WODC.2261		
#9 LEG CASTING ASSY(4) .....	ALDR.4807MBK		
#10 BOOST MANIFOLD .....	3105.111		

RIGHT AND LEFT ARE DETERMINED WHEN FACING THE FRONT OF THE STOVE  
ALL OTHER PARTS NOT INCLUDED IN ABOVE KITS ARE NOT SOLD SEPARATELY

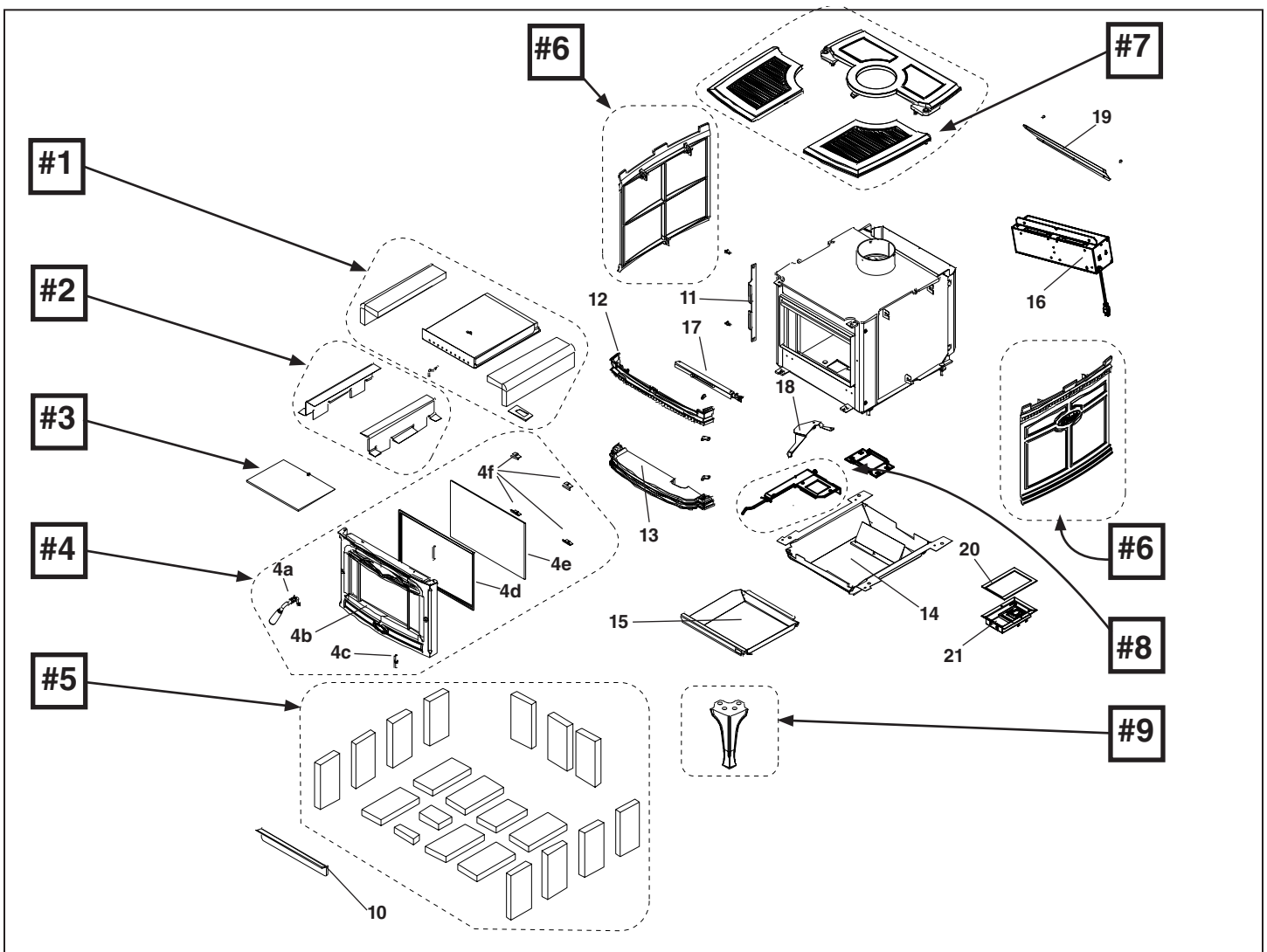

# Firebrick Installation Instructions

This package contains 19 full-size firebricks, as well as 5 various cut bricks.

With the woodstove in the upright position, install firebricks as follows:

1. Place the firebricks on the bottom of the unit first. Use a total of 6 full-size (D) and 5 cut bricks (A, B, C & 2E) with ash cleanout system.
2. Next install the side firebricks, 3 full-size and 2 cut firebricks(F) on each side of the firebox as shown.
3. Finally install 4 full-size bricks against the rear wall as shown.

ITEM	SIZE	
A	1 1/2" X 4 1/2" X 1 1/4"	(39 mm x 115 mm x 32 mm)
B	4" X 4 1/2" X 1 1/4"	(102 mm x 115 mm x 32 mm)
C	7 1/4" X 4 1/2" X 1 1/4"	(184 mm x 115 mm x 32 mm)
D	9" X 4 1/2" X 1 1/4"	(230 mm x 115 mm x 32 mm)
E	9" X 4 1/2" X ANGLED CUT	(230 mm x 115 mm (cut) x 32 mm)
F	9" X 3 1/2" X 1 1/4"	(102 mm x 115 mm x 32 mm)

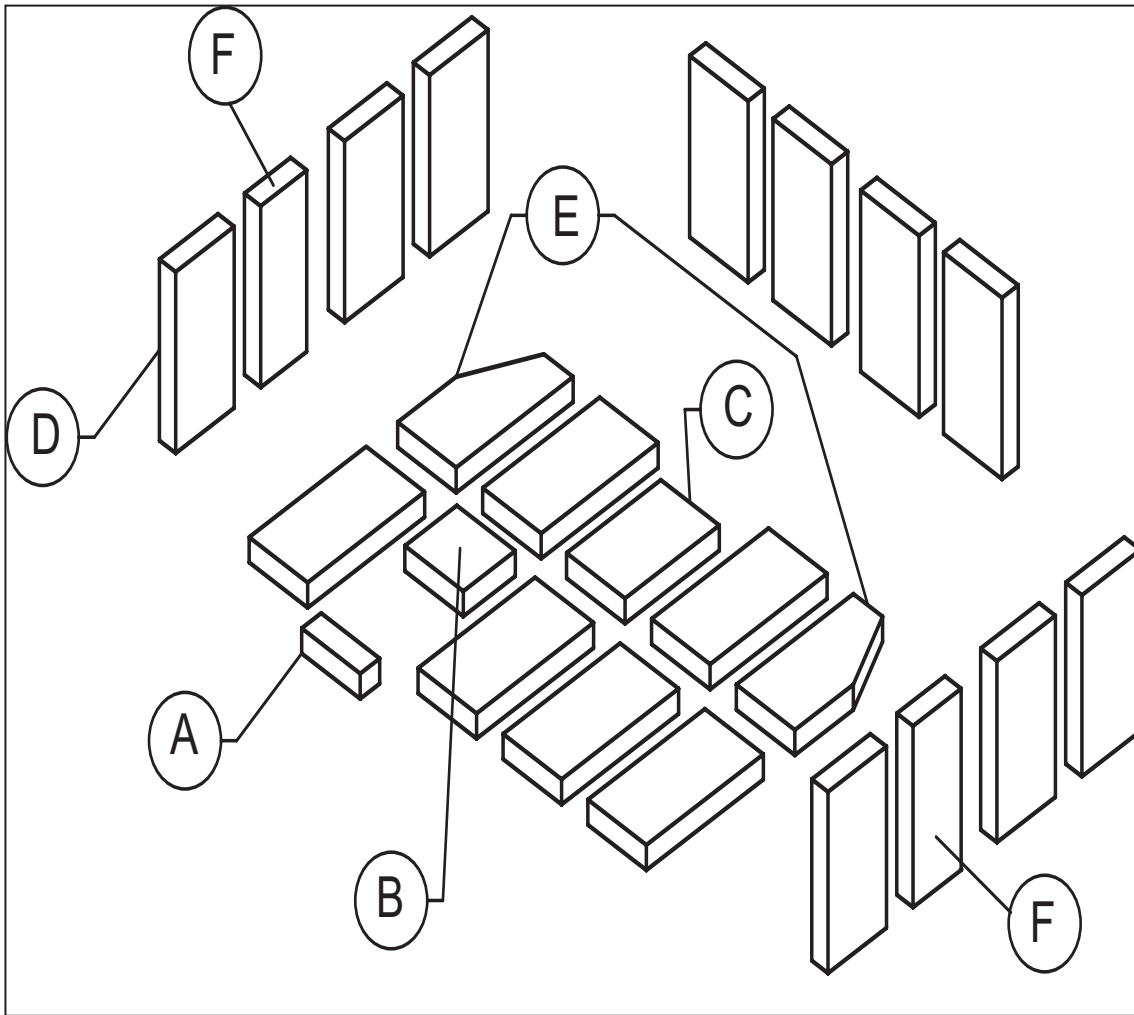

---

# Warranty Information

## Pacific Energy Limited Lifetime Warranty Wood Products

Pacific Energy extends the following warranty coverage to the original registered purchaser of the product:

### LTD Lifetime Coverage (10 years)

Limited lifetime coverage is extended to the following components (parts only) porcelain finish, glass (glass for thermal breakage only, not impact), plating, firebox and baffle.

### 3 Year Comprehensive

Pacific Energy will replace or repair any part found to be defective (parts and labor) for three years from the date of purchase.

This coverage includes electrical components (blowers, speed controls and thermal switches).

### Conditions:

**Your stove has been designed to perform in the harshest climates in North America. You can be confident that under normal use your stove will be trouble free for many years. If your stove is prematurely deteriorating this is a significant indicator of improper usage, for example; excessive draft, heating to large an area, contaminated fuel - such as high sodium content or plastics and chemicals. Please be aware, these conditions may be reasons to void your warranty.**

**For wood products** - All installations must be installed according to all applicable local and national codes. It is the responsibility of the installer to ensure the unit is operating correctly at installation.

Any part that shows in our judgment evidence of defect shall be repaired, replaced or refunded at Pacific Energy's option. The defective part may be required to be returned to Pacific Energy or an accredited agent, transportation prepaid.

**Porcelain** is warranted for gloss retention. Certain colors may darken when heated and return to the original shade when cool.

**Glass** is warranted against thermal breakage.

**Plating** is warranted against tarnishing. Gold plating may attain a deeper color with use.

### Exclusions

Limited Lifetime coverage - Lifetime coverage is limited to the repair, replacement or refund of the indicated parts only. Labor charges are not covered under the lifetime warranty.

The following items are not included in the Lifetime Warranty: firebox rails and heat shields.

The following parts are not warranted: firebrick, gaskets and ceramic fiber blankets.

This warranty does not apply to any part that shows evidence of misuse, abuse, improper installation, accident, lack of maintenance, or modification.

Pacific Energy shall in no event be liable for any special, indirect or consequential damages of any nature whatsoever which are in excess of the original purchase price of the product.

Pacific Energy is not responsible for installation, operational or environmental conditions beyond our control. (The company may, at its discretion, discharge all obligations by refunding the wholesale price of the defective part.)

**For Warranty claims, please contact your nearest Pacific Energy dealer.**









# Label



**CERTIFIED FOR CANADA AND U.S.A. - SERIES / SÉRIE: B**  
**LISTED ROOM HEATER SOLID FUEL TYPE**  
**ALSO FOR USE IN MOBILE HOMES**  
**TESTED TO / ÉPROUVÉ SELON: CANULC S627-00 AND UL 1482-2011**

**MODEL / MODÈLE: SUMMIT** ■ **SUMMIT CLASSIC** ■ **ALDERLEA T6**

**WH-**

DO NOT REMOVE THIS LABEL

- INSTALL AND USE IN ACCORDANCE WITH THE MANUFACTURER'S INSTALLATION AND OPERATING INSTRUCTIONS.
- CONTRACT LOCAL BUILDING OR FIRE OFFICIALS ABOUT RESTRICTIONS, INSTALLATION PERMIT AND INSPECTION IN YOUR AREA.
- DO NOT CONNECT THIS UNIT TO A CHIMNEY FLUE SERVING OTHERS APPLIANCE (USA - ONLY).
- CAN BE CONNECTED TO A LISTED MASONRY CHIMNEY, SUITABLE FOR USE WITH SOLID FUELS.
- SEE LOCAL BUILDING CODE AND MANUFACTURER'S INSTRUCTIONS FOR PRECAUTIONS REQUIRED WHEN PASSING A CHIMNEY THROUGH A COMBUSTIBLE WALL OR CEILING.
- DO NOT PASS A CHIMNEY CONNECTOR THROUGH A COMBUSTIBLE WALL OR CEILING.
- MINIMUM CLEARANCE BETWEEN SINGLE WALL CHIMNEY CONNECTOR AND COMBUSTIBLE MATERIALS (OTHER THAN CEILING) MAY BE REDUCED BY THE USE OF LISTED FIRE SHIELDS, WALL BRACKETS OR OTHER APPROVED CLEARANCE REDUCING DEVICES.
- COMPONENTS REQUIRED FOR MOBILE HOME AND ALCOVE INSTALLATION: OUTSIDE AIR KIT, BOTH CHIMNEY SYSTEM AND CONNECTOR MUST BE LISTED TO:
- IN CANADA - UL-C 5641 LISTED CONNECTOR AND UL-C-S-629 LISTED CHIMNEY
- IN USA - UL-103 HT LISTED CONNECTOR AND CHIMNEY
- APPLIANCE MUST BE INSTALLED WITH PEXIDAL OR LEG KIT ATTACHED.
- USE COMPONENTS SPECIFIED IN PACIFIC ENERGY INSTALLATION INSTRUCTIONS.
- DO NOT OPERATE WITH THE HEATER ON FOR MORE THAN 15 MINUTES AT A TIME.
- DO NOT TOUCH HEATER OR CHIMNEY WHEN HEATER IS ON.
- CAUTION: RISK OF EXCESSIVE TEMPERATURES - KEEP ASH DUMP CLOSED DURING FIRING OF THE HEATER.
- OPERATE ONLY WITH FEED DOOR CLOSED. OPEN TO FEED FIRE ONLY.
- KEEP FURNISHINGS AND OTHER COMBUSTIBLE MATERIALS WELL AWAY FROM HEATER.
- REPLACE GLASS ONLY WITH CERAMIC GLASS.
- HORIZONTAL CONNECTOR NOT PERMITTED IN MOBILE HOMES.
- COMBUSTIBLE FLOOR MUST BE PROTECTED BY A CONTINUOUS NON-COMBUSTIBLE MATERIAL EXTENDING TO THE FRONT, SIDES AND BACK AS INDICATED.
- HOT WHILE IN OPERATION. DO NOT TOUCH. KEEP CHILDREN, CLOTHING AND FURNITURE AWAY. CONTACT MAY CAUSE SKIN BURNS. SEE NAMEPLATE AND INSTRUCTIONS. // CHAUD LORSQU'EN OPERATION. NE PAS TOUCHER. TENEZ LES ENFANTS ET LES VÊTEMENTS BIEN À L'ÉCART. LE CONTACT PEUT CAUSER DES BRÛLURES A LA PEAU. CONSULTEZ LA PLAQUE CE CONSTRUCITEUR ET LES INSTRUCTIONS.
- U.S. ENVIRONMENTAL PROTECTION AGENCY CERTIFIED TO COMPLY WITH JULY, 1990, PARTICULATE EMISSION STANDARDS/ CERTIFIÉ PAR L'AGENCE DE PROTECTION DE L'ENVIRONNEMENT DES ÉTATS-UNIS (EPA) EN ACCORD AVEC LES STANDARDS DÉMISION DE PARTICULES DE JUILLLET, 1990

051112

## REAR VIEW

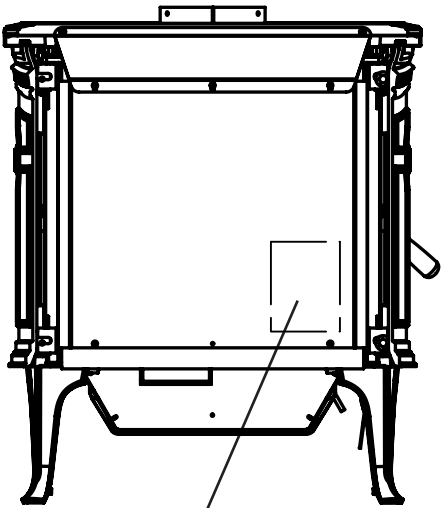

LABEL LOCATION

MINIMUM CLEARANCES TO COMBUSTIBLE MATERIALS / DÉGAGEMENTS MINIMAUX AUX MATÉRIAUX COMBUSTIBLES	RESIDENTIAL INSTALLATION / INSTALLATION RESIDENTIELLE UTILISANT UN RACCORD EN TUBES SIMPLE	RESIDENTIAL INSTALLATION / INSTALLATION RESIDENTIELLE UTILISANT UN RACCORD EN TUBES DOUBLE
A. SIDEWALL TO UNIT / MUR DE CÔTÉ / PAREPEL	14 in. / 356 mm	14 in. / 356 mm
B. MUR DE CÔTÉ / PAREPEL	9 in. / 229 mm	9 in. / 229 mm
C. CORNER TO UNIT / MUR DE CÔTÉ / PAREPEL	152 mm	152 mm
D. BACKWALL TO CONNECTOR / MUR DE CÔTÉ / RACCORD	23.8 in. / 605 mm	23.8 in. / 605 mm
E. BACKWALL TO CONNECTOR / MUR DE CÔTÉ / RACCORD	14.5 in. / 368 mm	14.5 in. / 368 mm
F. REAR WALL TO CHIMNEY / MUR ARRIÈRE / MUR COTE	28.6 in. / 727 mm	28.6 in. / 727 mm
G. REAR WALL TO CHIMNEY / MUR ARRIÈRE / MUR COTE	14.5 in. / 368 mm	14.5 in. / 368 mm
H. REAR WALL TO CHIMNEY / MUR ARRIÈRE / MUR COTE	26.6 in. / 676 mm	26.6 in. / 676 mm
I. REAR WALL TO CHIMNEY / MUR ARRIÈRE / MUR COTE	14.5 in. / 368 mm	14.5 in. / 368 mm
J. REAR WALL TO CHIMNEY / MUR ARRIÈRE / MUR COTE	26.6 in. / 676 mm	26.6 in. / 676 mm
K. REAR WALL TO CHIMNEY / MUR ARRIÈRE / MUR COTE	14.5 in. / 368 mm	14.5 in. / 368 mm
L. REAR WALL TO CHIMNEY / MUR ARRIÈRE / MUR COTE	26.6 in. / 676 mm	26.6 in. / 676 mm
M. REAR WALL TO CHIMNEY / MUR ARRIÈRE / MUR COTE	14.5 in. / 368 mm	14.5 in. / 368 mm
N. REAR WALL TO CHIMNEY / MUR ARRIÈRE / MUR COTE	26.6 in. / 676 mm	26.6 in. / 676 mm
O. REAR WALL TO CHIMNEY / MUR ARRIÈRE / MUR COTE	14.5 in. / 368 mm	14.5 in. / 368 mm
P. REAR WALL TO CHIMNEY / MUR ARRIÈRE / MUR COTE	26.6 in. / 676 mm	26.6 in. / 676 mm
Q. REAR WALL TO CHIMNEY / MUR ARRIÈRE / MUR COTE	14.5 in. / 368 mm	14.5 in. / 368 mm
R. REAR WALL TO CHIMNEY / MUR ARRIÈRE / MUR COTE	26.6 in. / 676 mm	26.6 in. / 676 mm
S. REAR WALL TO CHIMNEY / MUR ARRIÈRE / MUR COTE	14.5 in. / 368 mm	14.5 in. / 368 mm
T. REAR WALL TO CHIMNEY / MUR ARRIÈRE / MUR COTE	26.6 in. / 676 mm	26.6 in. / 676 mm
U. REAR WALL TO CHIMNEY / MUR ARRIÈRE / MUR COTE	14.5 in. / 368 mm	14.5 in. / 368 mm
V. REAR WALL TO CHIMNEY / MUR ARRIÈRE / MUR COTE	26.6 in. / 676 mm	26.6 in. / 676 mm
W. REAR WALL TO CHIMNEY / MUR ARRIÈRE / MUR COTE	14.5 in. / 368 mm	14.5 in. / 368 mm
X. REAR WALL TO CHIMNEY / MUR ARRIÈRE / MUR COTE	26.6 in. / 676 mm	26.6 in. / 676 mm
Y. REAR WALL TO CHIMNEY / MUR ARRIÈRE / MUR COTE	14.5 in. / 368 mm	14.5 in. / 368 mm
Z. REAR WALL TO CHIMNEY / MUR ARRIÈRE / MUR COTE	26.6 in. / 676 mm	26.6 in. / 676 mm

- INSTALLER ET UTILISER SELON LES INSTRUCTIONS D'INSTALLATION ET D'OPERATION FOURNIES AVEC L'APPAREIL.
- CONTACTEZ LES OFFICIELS DE LA CONSTRUCTION OU DE SERVICE D'INCENDIE POUR DES INFORMATIONS QUANT AUX RESTRICTIONS PERMIS D'INSTALLATION ET INSPECTIONS DANS VOTRE REGION.
- NE RETENEZ PAS CE APPAREIL A UN COMBUSTIBLE OU A UN AUTRE APPAREIL (ENTRÉS-JUNTS SEULE).
- UTILISER UN RACCORDEMENT NOIR OU CLASSE DE 21ANS ET AVEC UN DIAMÈTRE D'AU MOINS 6 POUCES / 150 mm.
- PEUT ÊTRE CONNECTÉ À UNE CHIMÈNEE DE MAÇONNERIE ALIGNEE PRÊTE À L'EMPLOI AVEC DES COMBUSTIBLES SOLIDES.
- DO NOT OBSTRUCT THE SPACE BENEATH THE HEATER / CONSULTER LE CODE LOCAL DE CONSTRUCTION ET LES INSTRUCTIONS DU FABRICANT QUANT AUX PRÉCAUTIONS À PRENDRE LORSQUE VOUS FAITES PASSER UNE CHIMÈNEE À TRAVERS D'UN MUR OU D'UN PLAFOND COMPOSÉS DE MATÉRIAU COMBUSTIBLES.
- NE PAS PASSER UN RACCORDEMENT DE CHIMÈNEE À TRAVERS D'UN MUR OU D'UN PLAFOND COMPOSÉS DE MATÉRIAU COMBUSTIBLES.
- DÉGAGEMENT MINIMAL ENTRE UN RACCORDEMENT DE CHIMÈNEE À TRAVERS D'UN MUR OU D'UN PLAFOND COMPOSÉS DE MATÉRIAU COMBUSTIBLES: 18 POUCES / 457 mm. CE DÉGAGEMENT PEUT ÊTRE RÉDUIT EN UTILISANT DES PROTECTEURS DE TUYAUX CLASSES PROTECTEURS DE MUR OU AUTRES MOYENS APPROUVÉS PAR LES OFFICIELS DE LA CONSTRUCTION OU DU SERVICE D'INCENDIE DE VOTRE REGION.
- CONNECTEUR HORIZONTAL NON PERMIS DANS MAISONS MOBILES.
- NE PAS PASSER UN RACCORDEMENT DE CHIMÈNEE À TRAVERS D'UN MUR OU D'UN PLAFOND COMPOSÉS DE MATÉRIAU COMBUSTIBLES.
- PIÈCES REQUISES POUR INSTALLER EN MAISON MOBILE OU EN ALCOVE: NÉCESSAIRE D'APPROUVISSEMENT D'AIR EXTÉRIEUR ET L'UN DES RACCORDS SUIVANTS: EN COMBINAISON AVEC L'UN DES SYSTÈMES DE CHIMÈNEE COMPATIBLES SUIVANTS.
- AU CANADA - LE UL-C 5641 CONNECTEUR ENUMÉRÉS ET UL-C-S-629 ONT ÉNUMÉRÉS CHIMÈNEE PIÈCES EN OPTION - NÉCESSAIRES DE SOUTÈRE, INDICES ÉLECTRIQUES DE SUFFLERIE: 115V, 60HZ, 1.0 AMP. LE FIL ÉLECTRIQUE NE DOIT PAS ÊTRE PLACÉ SOUS LE POÊLE.
- LE FIL ÉLECTRIQUE NE DOIT PAS ÊTRE PLACÉ SOUS LE POÊLE.
- LE FIL ÉLECTRIQUE NE DOIT PAS ÊTRE PLACÉ SOUS LE POÊLE.
- LE FIL ÉLECTRIQUE NE DOIT PAS ÊTRE PLACÉ SOUS LE POÊLE.
- OUVREZ SEULEMENT LORSQUE LA PORTE D'ALIMENTATION EST FERMÉE.
- GARDEZ LES MEUBLES ET AUTRES MATÉRIAUX COMBUSTIBLES BIEN ÉLOIGNÉS DU POÊLE.
- REMPLACEZ LA VITRE AVEC UN JOUET DE LA VITRE CERAMIQUE.
- CONNECTEUR HORIZONTAL NON PERMIS DANS MAISONS MOBILES.
- TOUT QUOI ÉTOUFEUR DE PROTECTION DE TUBA PEUT ÊTRE NÉCESSAIRE DANS LES SITUATIONS LOCALES.
- LE PLANCHER COMBUSTIBLE DOIT ÊTRE PROTÉGÉ PAR UN MATÉRIEL NON-COMBUSTIBLE TOUT D'UNE PIÈCE QUI DOIT S'ÉTENDRE DE PART EN DEHORS, LES CÔTÉS ET L'ARRIÈRE TEL QU'INDIQUÉ.

MADE IN CANADA / FABRIQUÉ AU CANADA

5090 / 7601



**CAUTION**

PACIFIC ENERGY

MANUFACTURED BY / FABRIQUÉ PAR:  
 PACIFIC ENERGY  
 2875 ALDENBY RD. DUNCAN, BC V9L 6V8  
 DATE OF MANUFACTURE / DATE DE FABRICATION: 2012 2013 2014 2015 2016 2017

U.S. MODEL NO. / NO. MODÈLE U.S.: J F M A M J J A S O N D

CANADIAN MODEL NO. / NO. MODÈLE CANADAIN: 5090 / 7601





By Pacific Energy

**PACIFIC ENERGY FIREPLACE PRODUCTS LTD.**

**2975 Allenby Rd., Duncan, B.C. V9L 6V8**

**For technical support, please contact your retailer.**

**Web site: <http://www.pacificenergy.net>**

PRINTED IN CANADA

