



INSTALLATION & OPERATION GUIDE



ALDERLEA CAST IRON WOOD STOVE

MODELS T4, T5, T6

SAFETY NOTICE

If this stove is not properly installed, a house fire may result. For your safety, follow the installation instructions. Contact local building or fire officials about restrictions and installation inspection requirements in your area.

PLEASE SAVE THESE INSTRUCTIONS



TESTED and LISTED to
CAN/ULC S627 AND UL 1482
Meets the Environmental Protection Agency's
July 1990 Particulate Emission Standards



Contents

Safety and Maintenance	3
Creosote	4
Formation and Need for Removal	4
Chimney Fires.....	4
Avoiding a Chimney Fire	4
In Case of a Chimney Fire	5
Appliance Dimensions	6
Installation – Residential	7
Clearances – Residential	7
Minimum Clearances to Combustibles – Residential.....	7-8
Chimney and Connector	9
Double-Wall Connector.....	10
Single-Wall Connector	10
Installation Procedure	10
Installation – Mobile Home	11
Clearances – Mobile Home.....	11
Minimum Clearances to Combustibles – Mobile Home	11-12
Listed Chimney and Chimney Connector for Mobile Home Installation	13
Installation Procedure	13
Floor Protector	14
Combustion Air	14
Operation	15
Wood Selection.....	15
How to Test Your Wood.....	15
Lighting for the First Time	16
Lighting a Fire	16
Normal Operation.....	16
Restarting After Extended or Overnight Burns.....	17
More Wood, More Heat.....	17
Proper Draft.....	17
Ash Removal.....	17
Disposal of Ashes	18
Baffle Removal	18
Removal.....	18
Optional Blower	18
Blower Operation	18
APPENDIX A	
Troubleshooting	19
T4 Replacement Parts	20
T5 Replacement Parts	21
T6 Replacement Parts	22
Firebrick Installation Instructions	23
Label T4	24
Label T5	25
Label T6	26

NOTE:
WE STRONGLY RECOMMEND THAT SMOKE DETECTORS BE INSTALLED.

If smoke detectors have been previously installed, you may notice that they are operating more frequently. This may be due to curing of stove paint or fumes caused by accidentally leaving the fire door open. Do not disconnect the detectors. If necessary, relocate them to reduce their sensitivity.

SAFETY NOTICE:
If this stove is not properly installed, a house fire may result. For your safety, follow the installation instructions. Contact local building or fire officials about restrictions and installation inspection requirements in your area.

Please read this entire manual before you install and use your new room heater. Failure to follow instructions may result in property damage, bodily injury, or even death.

Safety and Maintenance

1. Burn only dry and well seasoned wood. The denser or heavier the wood when dry, the greater its heat value. This is why hardwoods are generally preferred. Green or wet wood will cause a rapid buildup of creosote. If you feel it is necessary to burn wet or unseasoned wood, do so only with the air inlet set open enough to maintain a good strong fire and fairly high chimney temperatures. Do not attempt to burn overnight using green wood or wet wood. Wet wood will reduce heat output, as well as contributing significantly to creosote buildup.
2. Remove ashes frequently and only when cold. Too much ash could cause embers to roll out the door when it is opened. This may pose a fire hazard. For proper operation, maintain a 1" minimum ash base.
3. If glass becomes darkened through slow burning or poor wood, it can readily be cleaned with fireplace glass cleaner when stove is cold. Never scrape with an object or use abrasive cleaners that might scratch the glass. The type and amount of deposit on the glass is a good indication of the flue pipe and chimney buildup. A light brown dusty deposit that is easily wiped off usually indicates good combustion and dry, well-seasoned wood and therefore relatively clean pipes and chimney. On the other hand, a black greasy deposit that is difficult to remove is a result of wet and green wood and too slow a burning rate. This heavy deposit is building up at least as quickly in the chimney.
4. DOOR GASKETS - The gasket used by Pacific Energy (5/16" medium density fiberglass rope) requires only light pressure to seal. This will prolong seal life. It is important that the door seal be maintained in good condition. Periodically inspect seals and replace if necessary. Follow instructions included in the door gasket kit obtainable from your nearest Pacific Energy dealer.
5. DOOR GLASS - Do not slam loading door or otherwise impact glass. When closing door, make sure that no logs protrude to impact the glass. If the glass gets cracked or broken, **it must be replaced before using the stove.** Replacement glass can be obtained from your dealer. Use ceramic glass only. **Do not substitute with any other type.**
 - T4 – 16.250" x 10.5" x 5mm
 - T5 – 17.25" x 11.395" x 5mm
 - T6 – 20.125" x 11.875" x 5mm

To remove broken glass, undo the four retaining screws and remove clamps, noting position for re-assembly. Remove all particles of glass. Be careful as they are very sharp. Install new glass complete with gasket. Replace clamps and screws.
6. Do not store wood within heater installation clearances, or within the space required for fuel loading and ash removal. Keep the area around the heater clean and free of loose combustibles, furniture, newspapers, etc.
7. If the heater requires cleaning, use mild soap and water only. **Use of abrasive cleaners will void warranty.**
8. Establish a routine for fuelling and firing the heater. Check daily for creosote buildup until experience shows how often you need to clean the chimney to be safe.
9. Be aware that the hotter the fire, the less creosote is deposited. Weekly cleaning may be necessary in mild weather, even though monthly cleaning is usually enough in the coldest months when burning rates are higher.
10. Instruct all members of your family on the safe operation of the heater. Ensure they have enough knowledge of the entire system if they are expected to operate it. Study the section on chimney fires and the importance of following the steps outlined "In Case of Chimney Fire".

WARNING:

Never use chemicals or any other volatile liquid to start a fire. Do not burn garbage, or flammable fluids such as gasoline, naphtha, or engine oil. We strongly recommend that smoke detectors be installed.

WARNING:

Only use materials supplied by manufacturer when doing maintenance or replacements.

CAUTION:

- do not overtighten, tighten screws very carefully
- do not clean glass when hot
- do not use abrasive cleaners on glass

NATIONAL
FIREPLACE
INSTITUTE



CERTIFIED



Wood Energy
Technical Training

We recommend that our woodburning hearth products be installed and serviced by professionals who are certified in the U.S. by the National Fireplace Institute® (NFI) as NFI woodburning Specialists or who are certified in Canada by Wood Energy Technical Training (WETT).

Creosote

Formation and Need for Removal

When wood is burned slowly, it produces tar and other organic vapours, which combine with expelled moisture to form creosote. The creosote vapours condense in the relatively cool chimney flue of a slow burning fire. As a result, creosote residue accumulates on the flue lining. When ignited, this creosote makes an extremely hot fire.

The chimney connector and chimney should be inspected periodically (at least once every two months) during the heating season to determine if a creosote buildup has occurred. If creosote has accumulated (3 mm. or more), it should be removed to reduce the risk of a chimney fire.

1. Highest smoke densities occur when a large amount of wood is added to a bed of hot coals and the air inlet is closed. The heated wood generates smoke, but without ample air, the smoke cannot burn. Smoke-free, clean burning requires small fuel loads, two or three logs at a time or 1/4 to 1/2 of fuel load and leaving the air inlet relatively wide open, especially during the first 10 to 30 minutes after each loading, when most of the smoke generating reactions are occurring. After 30 minutes or so, the air inlet can be turned down substantially without excessive smoke generation. Wood coals create very little creosote-producing smoke.
2. The cooler the surface over which the wood smoke is passing, the more creosote will be condensed. Wet or green wood contributes significantly to creosote formation as the excess moisture that is boiled off cools the fire, making it difficult for the tars and gases to ignite, thus creating dense smoke and poor combustion. This moisture-laden smoke cools the chimney, compounding the problem by offering the smoke the ideal place to condense.

In summary, a certain amount of creosote is inevitable and must be lived with. Regular inspection and cleaning is the solution. The use of dry, seasoned wood and ample combustion air will help to minimize the buildup.

Chimney Fires

Excessive creosote build-up can cause a chimney fire. Creosote comes from tar and organic vapours released from a slow burning wood fire. Flammable creosote will condense and accumulate in the lining of a relatively cool chimney. When ignited, this creosote can result in an extremely hot fire.

Avoiding a Chimney Fire

There are two ways to avoid chimney fires:

1. Keep your chimney clear of creosote build-up by cleaning your chimney before each burn season, and as necessary (accumulations of 3 mm/1/8" or more) during the season.
2. Burn clean well-seasoned wood only (seasoned at least one year). Avoid wet or green wood.
3. Do not burn household trash, cardboard, plastics, construction lumber, treated or beach wood. (salt from beach wood will corrode your fireplace and void your warranty)
4. Do not leave the air inlet wide-open for extended periods of time.
5. Keep a fire extinguisher handy.

-
6. Prepare a home evacuation plan with a place outside where everyone is to meet.

If You Suspect a Chimney Fire

Signs of a chimney fire may be one or more of the following:

1. A roaring sound
2. Vibration of the chimney
3. Flames and sparks shooting out of the top of the chimney

In Case of a Chimney Fire

1. Immediately close the air inlets on the stove.
2. Evacuate the home, and call the local fire department.
3. After the chimney fire has been extinguished, the chimney must be cleaned and checked for stress and cracking before starting another fire. Also check combustibles around the chimney and roof.

We recommend that our woodburning hearth products be installed and serviced by professionals who are certified in the U.S. by the National Fireplace Institute® (NFI) as NFI woodburning Specialists or who are certified in Canada by Wood Energy Technical Training (WETT).

Appliance Dimensions

Fig #1

MODEL T4

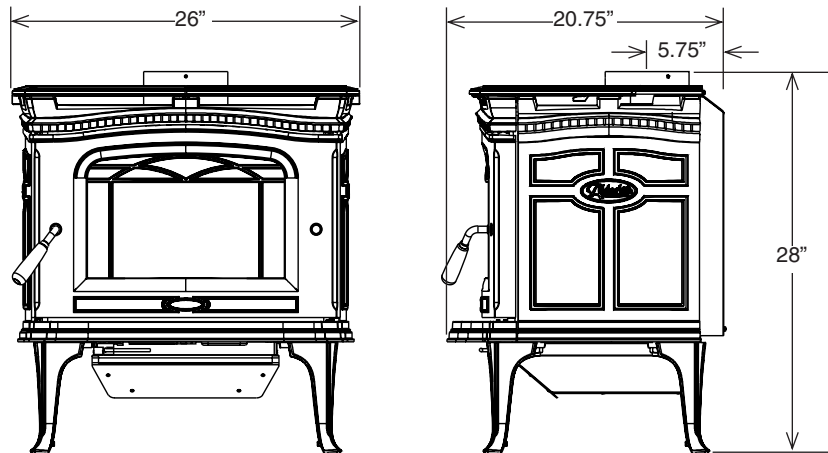

MODEL T5

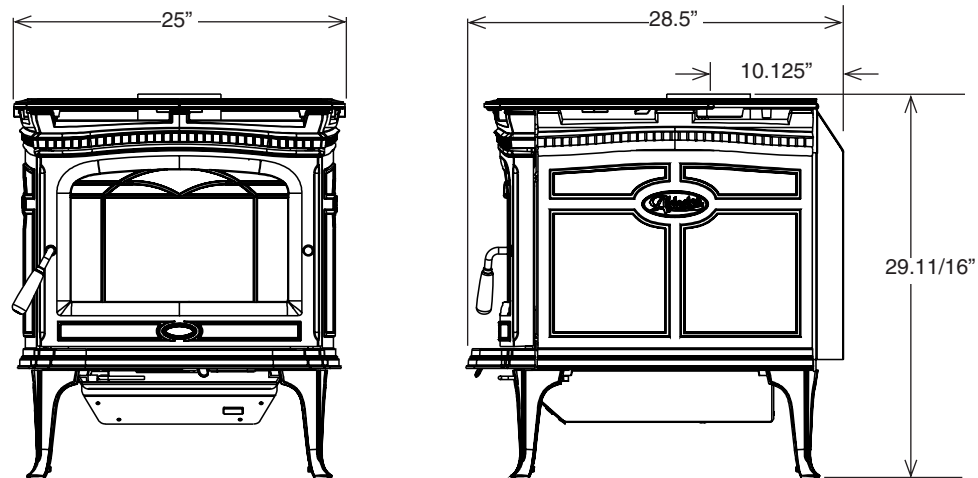

MODEL T6

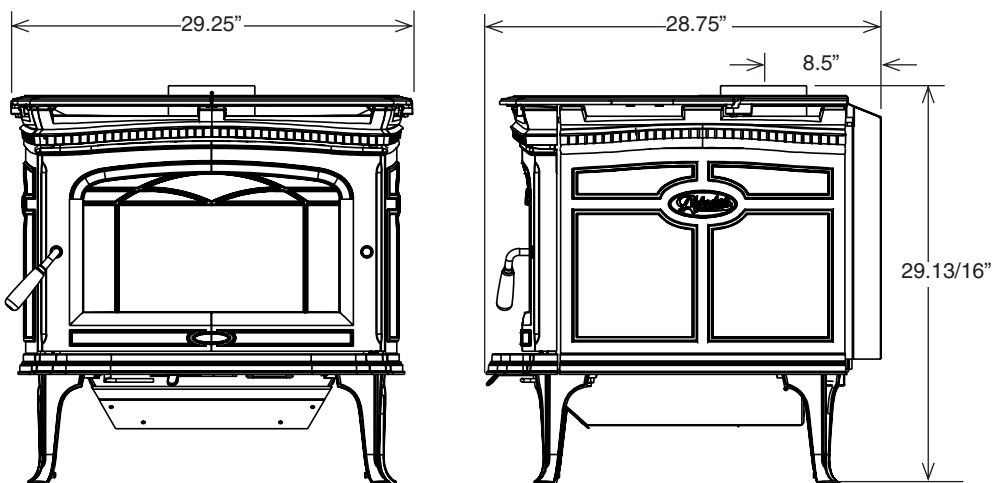

Installation – Residential

Warning:

Under no circumstances is this heater to be installed in a makeshift or "temporary" manner. It may be fired only after the stove is installed properly.

- DO NOT ATTEMPT TO CONNECT THIS HEATER TO ANY AIR DISTRIBUTION DUCT.
- We recommend that our woodburning hearth products be installed and serviced by professionals who are certified in the U.S. by the National Fireplace Institute® (NFI) as NFI woodburning Specialists or who are certified in Canada by Wood Energy Technical Training (WETT).
- Outside combustion air or fresh air into the room may be required in your area, consult local building codes (see Combustion Air section).

Do not connect this unit to a chimney flue serving another appliance.

Clearances – Residential

1. This heater may be installed using a single-wall connector (smoke pipe) or listed double-wall connector (see Mobile Home installation).
2. Clearances to combustibles surfaces and materials using single-wall connector are shown in Figures #2, #2b & #2d.

Clearances may be reduced with various heat insulating materials. Consult local fire codes and authorities for approval.

3. Alternately, for close clearances, use a listed double-wall connector. See Figures #2a, #2c & #2e.

Fig #2

Minimum Clearances to Combustibles – Residential

MODEL T4

SINGLE WALL CONNECTOR

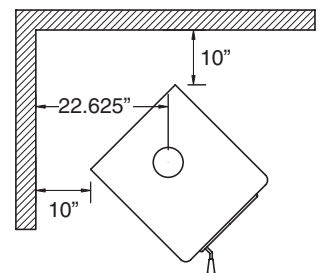
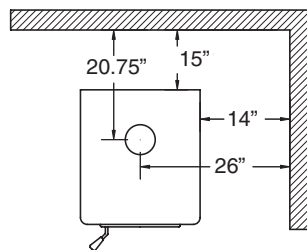
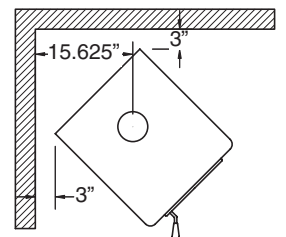
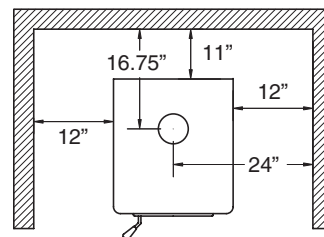
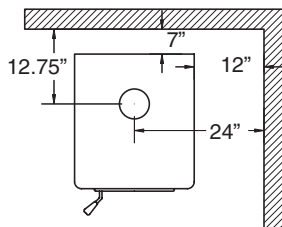

Fig #2a

DOUBLE WALL CONNECTOR



ALCOVE: Min. Height 7 1/2 feet
Max. Depth 4 feet

Fig #b

Minimum Clearances to Combustibles – Residential

MODEL T5

SINGLE WALL CONNECTOR

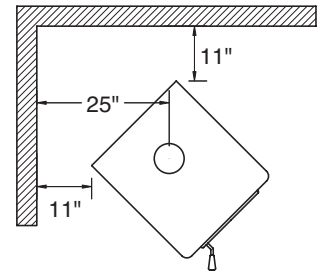
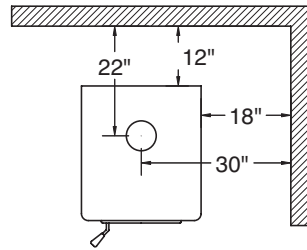
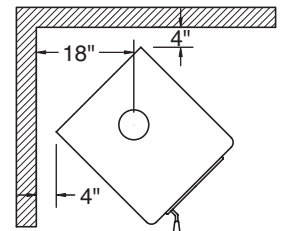
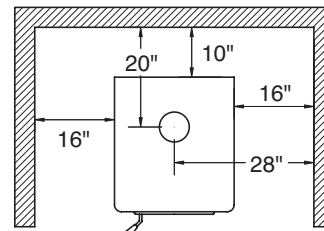
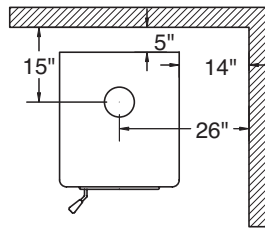

Fig #2c

DOUBLE WALL CONNECTOR



ALCOVE: Min. Height 7 1/2 feet
Max. Depth 4 feet

Fig #2d

Minimum Clearances to Combustibles – Residential

MODEL T6

SINGLE WALL CONNECTOR

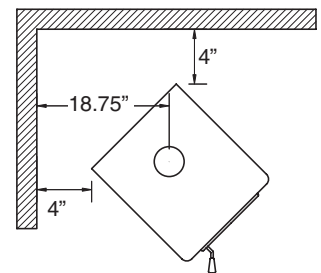
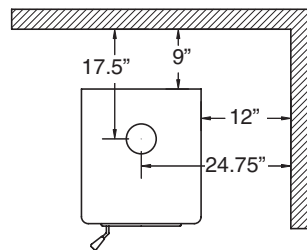
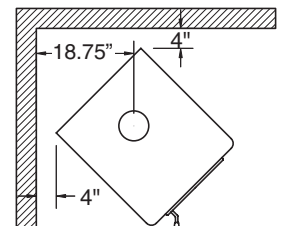
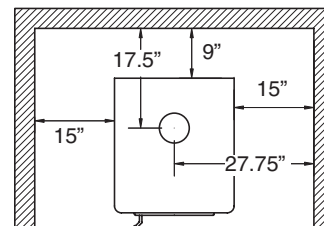
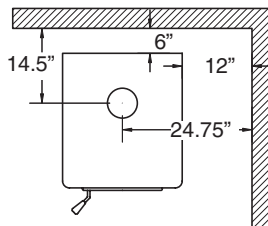

Fig #2e

DOUBLE WALL CONNECTOR



ALCOVE: Min. Height 7 1/2 feet
Max. Depth 4 feet

Chimney and Connector – Residential

Connect to a listed chimney or a chimney suitable for use with solid fuel that is lined and in good condition and meets local building codes. The chimney flue size should be the same as the stove outlet for optimal performance. Reducing or increasing the flue size may adversely affect stove performance. Chimney flue exit is to be 3 feet (1 m) above roof and two feet (0.6 m) above highest projection within 10 feet (3 m). The installation must meet all local codes. Do not connect this unit to a chimney flue serving another appliance. Minimum system height is 15 feet (4.6 m) (measured from base of appliance).

Fig #3

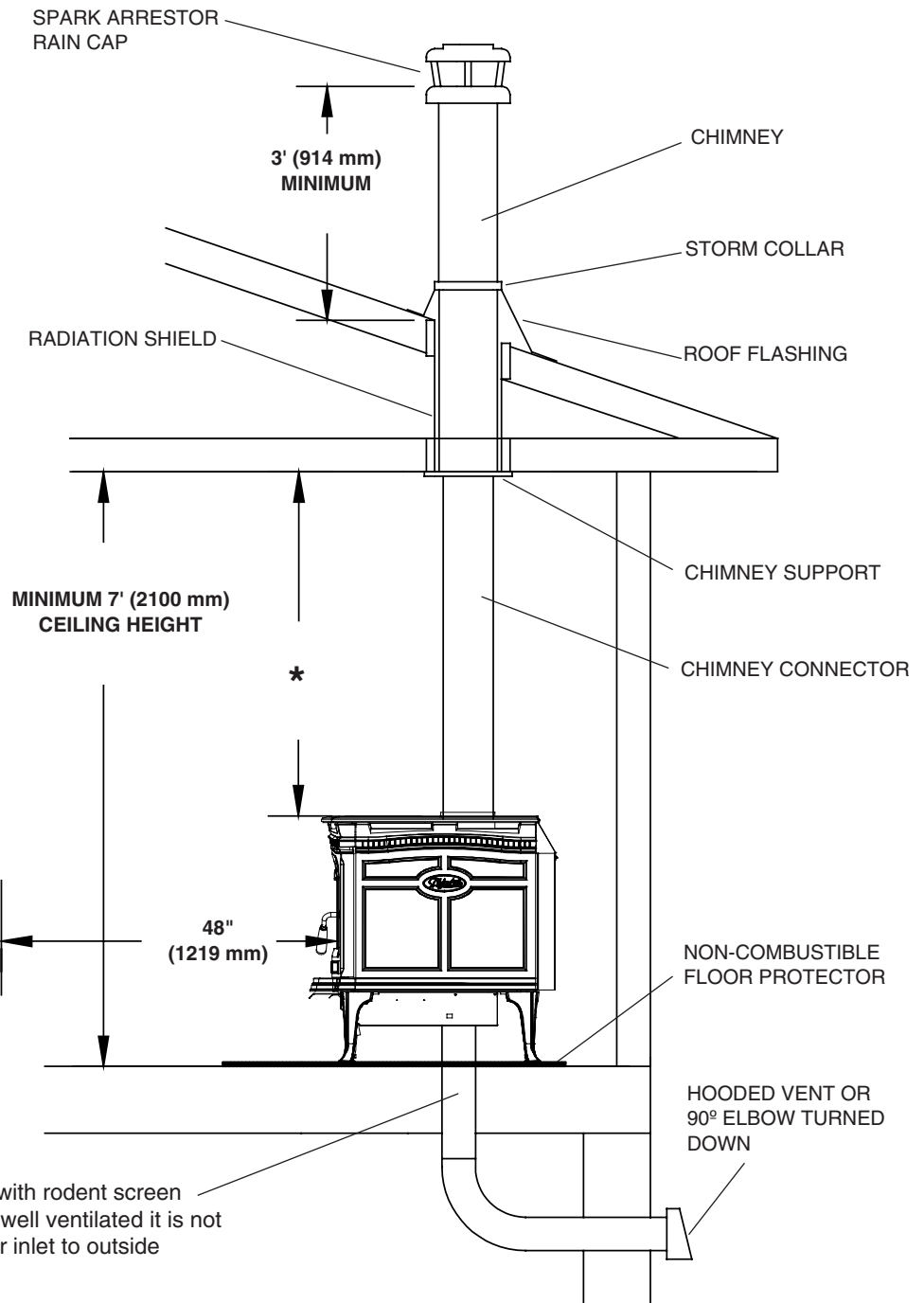

The chimney may incorporate an offset. To do this safely, all sections of listed connector, offset elbows and chimney section must be screwed together by at least three sheet metal screws per joint. The chimney must be suitably supported by the chimney manufacturer's listed offset support.

- * T4 - 56 3/4" (1441 mm)
- T5 - 55 1/4" (1403 mm)
- T6 - 56 1/2" (1409 mm)

- * 4" diameter air inlet with rodent screen
- * If the crawl space is well ventilated it is not necessary to extend air inlet to outside

Double-Wall Connector – Residential

- Use a listed double-wall connector suitable for solid fuel.
- Install all components to the chimney connector manufacturer's installation requirements.

Single-Wall Connector – Residential

Smoke pipe must be:

- As short and straight as possible, use six inch diameter, 24 gauge black pipe that is clean and in new condition.
- Secured at every joint and collar with 3 sheet metal screws.
- Installed with the crimped or male ends pointing down. This will carry any liquid creosote or condensation back into the stove.
- The chimney connector shall not pass through an attic, roof space, closet or similar concealed space, floor, or ceiling. Where passage through a wall, or partition of combustible material is desired, the installation shall conform to CAN/CSA-B365, Installation Code for Solid-Fuel-Burning Appliances and Equipment.

Installation Procedure – Residential

1. If a listed chimney and double-wall connector is to be connected to the stove, install all components to the chimney manufacturer's installation requirements. (Outside combustion air may be required, consult local building codes. See Combustion Air section on page 14.)
2. If it is desirable to use smoke pipe in conjunction with the insulated chimney, see step 4.
3. If a roof or ceiling support is used in the installation, you will find the chimney manufacturer's complete instructions packed with the roof support.
4. To start installing smoke pipe (chimney connector), slip crimped edge of the pipe inside the stove collar. Use holes provided in collar to secure pipe with two screws.
5. Install the remaining lengths of pipe one on top of the other to the finished height of the chimney connector and secure to each other.

Installation – Mobile Home

Warning:

Under no circumstances is this heater to be installed in a makeshift or "temporary" manner. It may be fired only after the following conditions have been met.

- **DO NOT CONNECT THIS UNIT TO A CHIMNEY FLUE SERVING ANOTHER APPLIANCE.**
- **DO NOT INSTALL IN A SLEEPING ROOM.**

Outside air supply must be used for Mobile Home installations see Figure #3, Page 9.

We recommend that our woodburning hearth products be installed and serviced by professionals who are certified in the U.S. by the National Fireplace Institute® (NFI) as NFI woodburning Specialists or who are certified in Canada by Wood Energy Technical Training (WETT).

CAUTION:

The structural integrity of the mobile home floor, wall, and ceiling/roof must be maintained.

Clearances – Mobile Home

This heater must be installed with listed double-wall connector and compatible chimney system listed on page 13.

Clearances to combustibles surfaces and materials are shown below in Figures #4a–c. Clearances may be reduced with various heat insulating materials. Consult local fire codes and authorities for approval.

NOTE: Longer chimney lengths and different pitch flashings may be used. All other parts listed must be installed (see Figure #3, Page 9). Install all components to the connector or chimney manufacturer's installation requirements. Consult your chimney supplier for installation advice.

Fig #4a

MODEL T4

Minimum Clearances to Combustibles – Mobile Home

DOUBLE WALL CONNECTOR

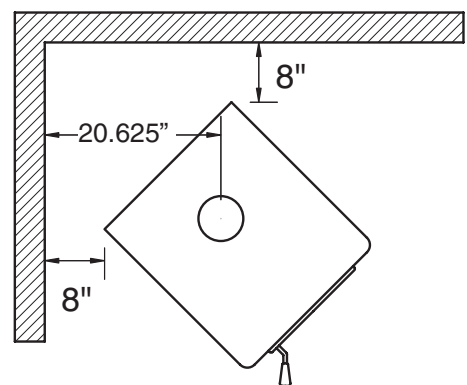
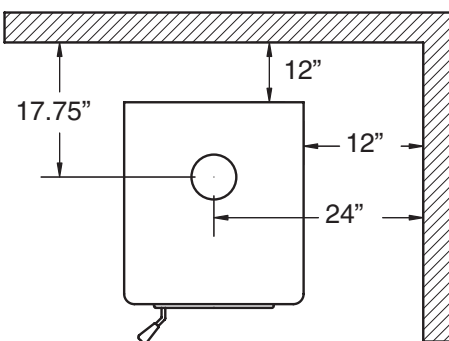

Fig #4b

MODEL T5

Minimum Clearances to Combustibles – Mobile Home

DOUBLE WALL CONNECTOR

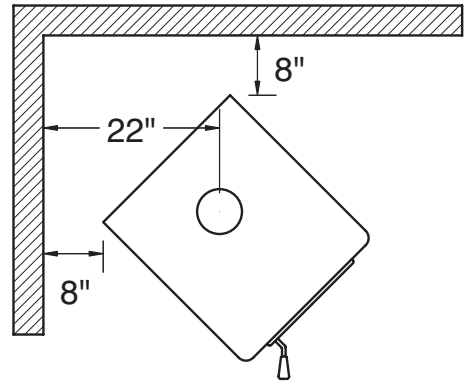
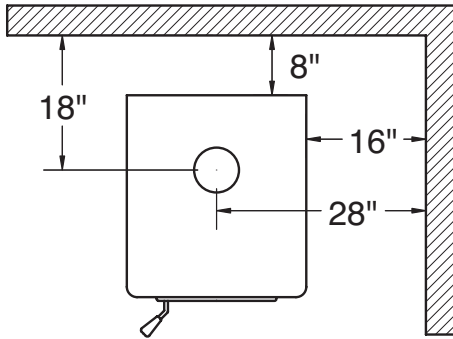
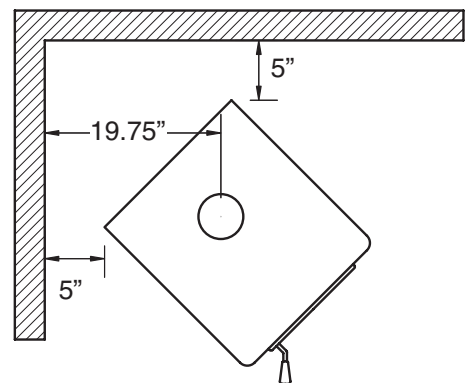
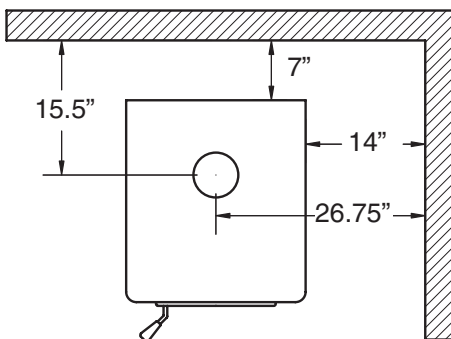

Fig #4c

MODEL T6

Minimum Clearances to Combustibles – Mobile Home

DOUBLE WALL CONNECTOR



Installation Procedure – Mobile Home

CAUTION: THE STRUCTURAL INTEGRITY OF THE MOBILE HOME FLOOR, WALL AND CEILING/ROOF MUST BE MAINTAINED.

Note: See "Combustion Air" section on page 14

1. Position stove and floor protection with hole for combustion air in accordance with the clearances as stated on the label and in Figures #4a–c.
2. Mark the position for the hole in the ceiling and roof by using a string and plumb-bob.
3. Check that the intended location will not interfere with floor joists, ceiling joists or rafters before proceeding further.
4. Cut a hole in the ceiling and roof to suit the chimney system and frame in the sides. The chimney support is mounted to the framing.
5. Assemble chimney sections so the finished length is resting on the support and protruding through the roof. Avoid having joints between ceiling and roof. Install radiation shield. Assemble flashing and storm collar and be sure to maintain the vapour barrier at this point. (Seal securely.) Attach rain cap and check flashing for leaks.
5. Install connector as per manufacturer's instructions.
6. To attach stove to floor, first remove the leveling bolts from the legs. Then attach stove to flooring using two 1/4" x 2" or longer lag screws through the leveling bolt holes.

Follow chimney and chimney components manufacturer's instruction for assembly and installation.

Listed Chimney and Chimney Connector for Mobile Home Installation

This appliance, when installed in a Mobile Home, must be installed with:

A. One of the following 6" double-wall connector systems:

- | | |
|---------------------------------|---|
| 1. Security Model DL or DC | 5. Metal Fab Model DW |
| 2. Oliver MacLeod Model PV | 6. Ameri-Tec Model DBSP |
| 3. Energy Vent | 7. Industrial Chimney Model Excel Ultra-Black |
| 4. Selkirk Metalbestos Model DS | 8. Simpson Dura-Vent Model DVL |

B. As well as one of the following compatible chimney systems - All parts 6":

CANADA ONLY:	Security S2100	Pro-Jet H.T.3000	ICC Excel 2100	Selkirk Sentinal CF	Energy Vent Commander 5000					
Ceiling support	XSF	FCS	SF	CF-CSP	CH6LCS					
Rafter radiation shield		RRS								
3' Chimney length	XL3	SL3	L3	CF-36SL	CH636					
2' Chimney length	XL2	SL2	L2	CF-24	CH624					
Roof flashing	XFA	RF17	FA	CF-FRA	CH6TCF					
Storm collar	XSC	SC	SC	CF-SC	CH6SC					
Spark arrestor rain cap	XCPE	RCSA	CPE	CF-SA,CT	CH6RC, SS					
USA ONLY:	Security S2100	Pro-Jet H.T.3000	Security ASHT	Pro-Jet HT3103	Metalbestos SSII	MetalFab 2100	Ameritech TEC HS	ICC Excel 103HT	Simpson Dura-Vent Dura/Plus	Dura Tech
Ceiling support	XSF	FCS	SF	FCS	T-SFA	TGCSP	6PL-CS	RDS/SQS	SDP-SB	SDP-SB
Rafter radiation shield		RRS		RRS	T-JSMH	TGRS				
3' Chimney length	XL3	SL3	L3	SL3	T-36	TG3	HS 36	CL48	SDP-P	SDT-P
2' Chimney length	XL2	SL2	L2	SL2	T-24	TG2	HS 24	CL24	SDP-P	SDT-P
Roof flashing	XFA	RF17	FA	RF	T-SFA	TGF	8RFFU	VF	SDP-F	SDT-F
Storm collar	XSC	SC	SC	SC	T-SC	TGSC	PL-ASCG	SC	SDP-SC	SDT-SC
Spark arrestor rain cap	XCPE	RCSA	CPE	RCSA	T-CT	TGC	6PL-MPC	RCS	SDP-C	SDT-C



Floor Protector

Fig #5

Canada Only

Minimum Width	T4 - 40"
	T5 - 40"
	T6 - 41 1/2"
Minimum Overall Depth	T4 - 43 1/4"
	T5 - 50 1/2"
	T6 - 50 1/2"

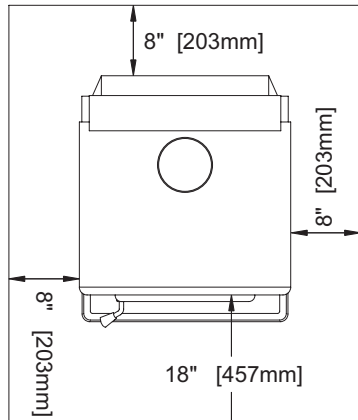

Non-combustible floor protector

The stove may be installed on a combustible floor provided noncombustible ember protection is used.

This protection must extend as follows:

In Canada: 18" (457 mm) on the firing side and 8" (203 mm) to the other sides. See Figure #5 on left.

In USA: 16" (406 mm) to the front and 8" (203 mm) to the sides of the fuel loading door opening. See Figure #6 on right. This protection is also required under the chimney connector and 2" (51 mm) beyond each side.

Fig #6

U.S.A. Only

Minimum Width	T4 - 32"
	T5 - 34"
	T6 - 36"
Minimum Overall Depth	T4 - 33 1/4"
	T5 - 40 1/2"
	T6 - 40 1/2"

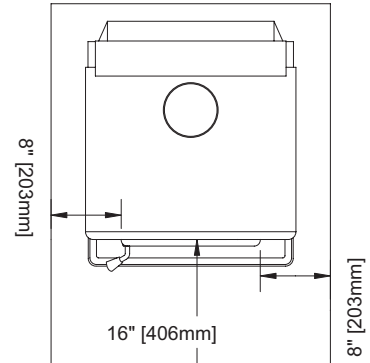

Non-combustible floor protector

Combustion Air

Intake or combustion air can be supplied to the stove in one of two ways. Consult your local building code or CAN/CSA-B365, Installation Code for Solid-Fuel-Burning Appliances and Equipment before proceeding.

1. **Outside air supply** - (Necessary for mobile home installation, optional for residential installation.) To draw outside air through the floor, cut or drill a 4" diameter hole directly below the bottom knockout hole of the ash box enclosure. Connect enclosure to the floor with a short 4" diameter pipe.

This hole must get its air from a **ventilated** crawl space or be extended with duct to the outdoors (see Figure #3, Page 9). The use of outside combustion air for residential installation requires the unit to be secured to the structure to prevent dislodging of the air duct.

Note: When installed in a mobile home, this unit is not designed to be operated with the firing door open. In addition to the obvious hazard of sparks landing on combustibles, an open fire door will cause the heater to draw air from the living space and possibly cause suffocation.

2. **Room air supply** - Remove the 4" knockout from the ash box enclosure. The stove will now draw its air from the room through this opening and into the firebox intake.

Note: The living space around the heater must be well ventilated with good air circulation. Anything that may cause a negative pressure can cause gases or fumes to be pulled into the living area. During extremely cold weather, and especially when burning at very slow rates, the upper parts of the exposed chimney may ice up, partially blocking the flue gases. If blockage occurs, flue gases may enter living space.

Operation

CAUTION:

Never use gasoline, gasoline type lantern fuel, kerosene, charcoal lighter fluid or similar liquids to start or "freshen up" a fire in this heater. Keep all such liquids well away from the heater while it is in use.

CAUTION:

Hot while in operation. Keep children, clothing and furniture away. Contact may cause skin burns.

Your PACIFIC ENERGY heater is designed for maximum overall efficiency at a moderate firing rate. Overfiring is hazardous and a waste of fuel. Too slow a burn contributes to creosote buildup and lowers combustion efficiency.

Wood Selection

This heater is designed to burn natural wood only. Higher efficiency and lower emissions generally result when burning air-dried seasoned hardwoods, as compared to softwoods or too green or freshly cut hardwoods.

Wood should be properly air dried (seasoned) for six months or more. Wet or undried wood will cause the fire to smoulder and produce large amounts of creosote. Wet wood also produces very little heat and tends to go out often.

DO NOT BURN :

- Salt water wood *
- Treated wood
- Wet or green wood
- Coal/charcoal
- Garbage/Plastic *
- Solvents

*** These materials contain chlorides which will rapidly destroy metal surfaces and void warranty.**

Do not burn anything but wood. Other fuels (eg. charcoal) can produce large amounts of carbon monoxide, a tasteless, odourless gas that can kill. Under no circumstances should you attempt to barbecue in this heater.

How to Test Your Wood

Add a large piece of wood to the stove when it has a good large bed of coals. It is dry if it is burning on more than one side within one minute. It is damp if it turns black and lights within three minutes. If it sizzles, hisses and blackens without igniting in five minutes it is soaked and should not be burnt.

Lighting for the First Time

Curing of the Paint Finish

To achieve the best finish, the paint on your stove must be baked on. When burning your stove for the first 2-3 times it is very important that the room be well ventilated. Open all windows and doors. Smoke and fumes caused by the curing process may cause discomfort to some individuals.

Lighting a Fire

WARNING: Never use chemicals or any other volatile liquid to start a fire.

1. Adjust air control to maximum firing position (start position) and open door.
2. Place crumpled newspaper in the centre of the heater and criss-cross with several pieces of dry kindling. Add a few small pieces of dry wood on top.
3. Ignite the paper and close the door.
4. After the fire has established itself, open the door and add a few small logs. Close the door.
5. Begin normal operation after a good coal base exists and wood has charred.

Normal Operation

1. Set air control to a desired setting. If smoke pours down across the glass (waterfall effect) this indicates you have shut the control down too soon or you are using too low a setting. As every home's heating needs vary (based on insulation, windows, climate, etc.) the proper setting can only be found by trial and error and should be noted for future burns.
2. To refuel, adjust air control to high, and give the fire time to brighten. Open the door slowly, this will prevent backpuffing.
3. Use wood of different shape, diameter and length (up to 18"). Load your wood endwise (side to side with Model T4) and try to place the logs so that the air can flow between them. Always use dry wood.
4. Do not load fuel to a height or in such a manner that would be hazardous when opening the door.
5. For extended or overnight burns, unsplit logs are preferred. Remember to char the wood completely on maximum setting before adjusting air control for overnight burn.

WARNING: Always keep loading door closed when burning. This heater is not designed for open door burning.

WARNING: No alteration or modification of the combustion air control assembly is permitted. Any tampering will void warranty and could be very hazardous.

WARNING: Do not use grates or andirons to elevate the fuel. Burn directly on the fire bricks. Replace broken or missing bricks. Failure to do so may create a hazardous condition.

Restarting After Extended or Overnight Burns

1. Open door and rake hot embers towards the front of the heater. Add a couple of dry, split logs on top of embers, close door.
2. Adjust air control to high (left position) and in just a few minutes, logs should begin burning.
3. After wood has charred, reset air control to desired setting.
4. To achieve maximum firing rate, set control to high (left position). Do not use this setting other than for starting or preheating fresh fuel loads.

DO NOT OVERFIRE THIS HEATER:
Attempts to achieve heat output rates that exceed heater design specifications can result in permanent damage to the heater and chimney.

More Wood, More Heat

Seasoned wood has approximately 7500 BTU's per pound. If you put 10 pounds of wood in your stove for an eight hour burn the wood will be producing 9375 BTU's per hour. (7500 BTU x 10 lbs./8hrs.=9375 BTU's per hr.) If you put 20 lbs of wood in your stove for eight hour burn you will get 18,750 BTU's per hr. (7500 BTU x 20lbs./8hr.=18,750 BTU's per hr.). This is only an example and is based on 100% efficiency. In reality, your stove should perform in the 70% efficiency range.

Experience will give you the right settings for proper combustion and efficient burning. Remember the correct air inlet setting is affected by variables such as type of wood, outside temperature, chimney size and weather conditions. With practice, you will become proficient in operating your heater and will obtain the performance for which it was designed.

Proper Draft

1. Draft is the force which moves air from the appliance up through the chimney. The amount of draft in your chimney depends on the length of the chimney, local geography, nearby obstructions and other factors.
2. Too much draft may cause excessive temperatures in the appliance. An uncontrollable burn or a glowing red stove part or chimney indicates excessive draft.
3. Inadequate draft may cause backpuffing into the room and plugging of the chimney. Smoke leaking into the room through appliance and chimney connector joints indicates inadequate draft.

Ash Removal

Whenever ashes get 3 to 4 inches deep in your firebox, and when fire has burned down and cooled, remove excess ashes. Leave an ash bed approximately 1" (25 mm) deep on the firebox bottom to help maintain a hot charcoal bed.

Ash Chute Operation: Your Alderlea stove is equipped with an ash chute system to ease removal of ash from the ash lip area. To use this system, first pull out the ash pan approximately 2", sweep the ash into the chute located to the right side of the ash lip, and close the ash pan again.

Ash Cleanout System: The ash dump handle is located under the ash lip on the left hand side. To operate ash dump, pull handle out 1/2" and turn clockwise. This will unlock the ash dump and allow it to open. Hold handle open while pulling ashes into the opening. Avoid large embers as these still contain heat value. Release handle and push in to lock. Ensure ash dump door is properly engaged. Fill the cavity with the remaining ash level with the firebox floor. Pull out ashpan and discard ashes into metal container. Replace ashpan and ensure it is seated properly.

CAUTION:
Ashes are to be removed only when the heater is cold.

Do not burn with ash dump door open. Doing so will create a hazardous condition. Always leave about 1" of ash when cleaning.

Disposal of Ashes

Ashes should be placed in a metal container with a tight fitting lid. The closed container of ashes should be placed on a non-combustible floor or on the ground, well away from all combustible materials, pending final disposal. If the ashes are disposed of by burial in soil or otherwise locally dispersed, they should be retained in closed container until all cinders have thoroughly cooled. Other waste should not be placed in this container.

Baffle Removal

Chimney connector pipe should be disconnected from stove to clean and inspect. Only if this is not possible should you remove baffle assembly.

DO NOT OPERATE WITH BAFFLE ASSEMBLY OR INSULATION REMOVED.

Removal

Remove retaining pin located at the rear top of the firebox, just below the baffle. Lift baffle up and pull forward to disconnect from the supply tube. Tilt baffle sideways to drop down and remove from firebox. Inspect gasket between baffle and supply tube. If necessary, replace with gasket #139.5 available from your Pacific Energy dealer. Re-install baffle assembly in reverse order. The two side pieces of insulation must be tight against the siderails.

Optional Blower

The optional blower kit (kit #WODC.BLOW) is equipped with a three prong power cord and may be installed at any time. Follow installation instructions supplied with the kit. Route power supply cord away from heater.

Electrical rating: 115 volts A.C.- 0.84 amps.

Fan output rating: 125 CFM

Blower Operation

Proper blower speed matched with air control setting will ensure peak performance from your stove. Operate as follows:

- Air control set to low (right position), operate blower speed control on "Low".
- Air control set between low and high (middle position), operate blower speed control at desired setting.

Automatic: To operate the blower automatically, set the rocker switch on the side of the fan housing to "Auto" and set the speed control to desired setting. This will allow the fan to turn on as the stove heats up to operating temperature. It will also shut the blower off after the fire has gone out and the unit cooled to below a useful heat output range.

Manual: To manually operate the blower, set the rocker switch to "Man" and set the speed control to desired setting. This will bypass the sensing device and allow full control of the blower.

Switching from "Auto" to "Man" or selecting speed may be done anytime.

APPENDIX A

Troubleshooting

Problem	Cause	Cure
Glass is Dirty	<ol style="list-style-type: none"> 1. Wood is wet 2. Turning down air control or damper too soon 3. Draft too low 4. Door gasket leakage 	<ul style="list-style-type: none"> • Use dry wood • Do not turn down until <ol style="list-style-type: none"> a) there is a good bed of coals b) the wood is charred • Improper chimney height and / or diameter, consult dealer • Chimney plugged or restricted, check flue • Provide outside air for combustion • Replace gasket • Check latch for proper operation
Excessive Creosote Buildup	See 1,2,3, above.	See 1,2,3, above.
Low Heat Output	<ol style="list-style-type: none"> 1. Wood is wet 2. Fire too small 3. Draft too low 	<ul style="list-style-type: none"> • Use dry wood • Build a larger fire • Chimney plugged or restricted, inspect and clean
Won't Burn Overnight	<ol style="list-style-type: none"> 1. Air control is set too high 2. Not enough wood 3. Draft too high 4. Poor quality or wet wood 	<ul style="list-style-type: none"> • Set air control lower • Unsplit wood is preferred for overnight burns • Excessive chimney height and/or diameter • Use good quality, dry wood
Wood Won't Burn	<ol style="list-style-type: none"> 1. Combustion air supply blocked 2. Draft too low 	<ul style="list-style-type: none"> • Check outside air supply for obstruction • Check that room air cover is removed • Chimney plugged or restricted, inspect and clean • Chimney oversized or otherwise unsuitable, consult Dealer

T4 Replacement Parts

- #1 BAFFLE KIT VIST.BAFKIT
- #2 BRICK RAILS (2) VIST.RAILSET
- #3 FLAME SHIELD VIST.2115
- #4 DOOR ASSEMBLY ALT4.4900MBK
- #5 FIREBRICK SET BRIC.VISTA
- #6 SIDE CASTING MBK (2)..... ALT4.4905MBK
- #7 TOP GRILL ASSEMBLY (3)ALT4.TGASSYMBK
- #8 ASH DUMP ASSEMBLY ALDR.4731
- #9 LEG CASTING (4)..... ALDR.4807MBK

ALL OTHER PARTS NOT INCLUDED IN ABOVE KITS ARE NOT SOLD SEPARATELY

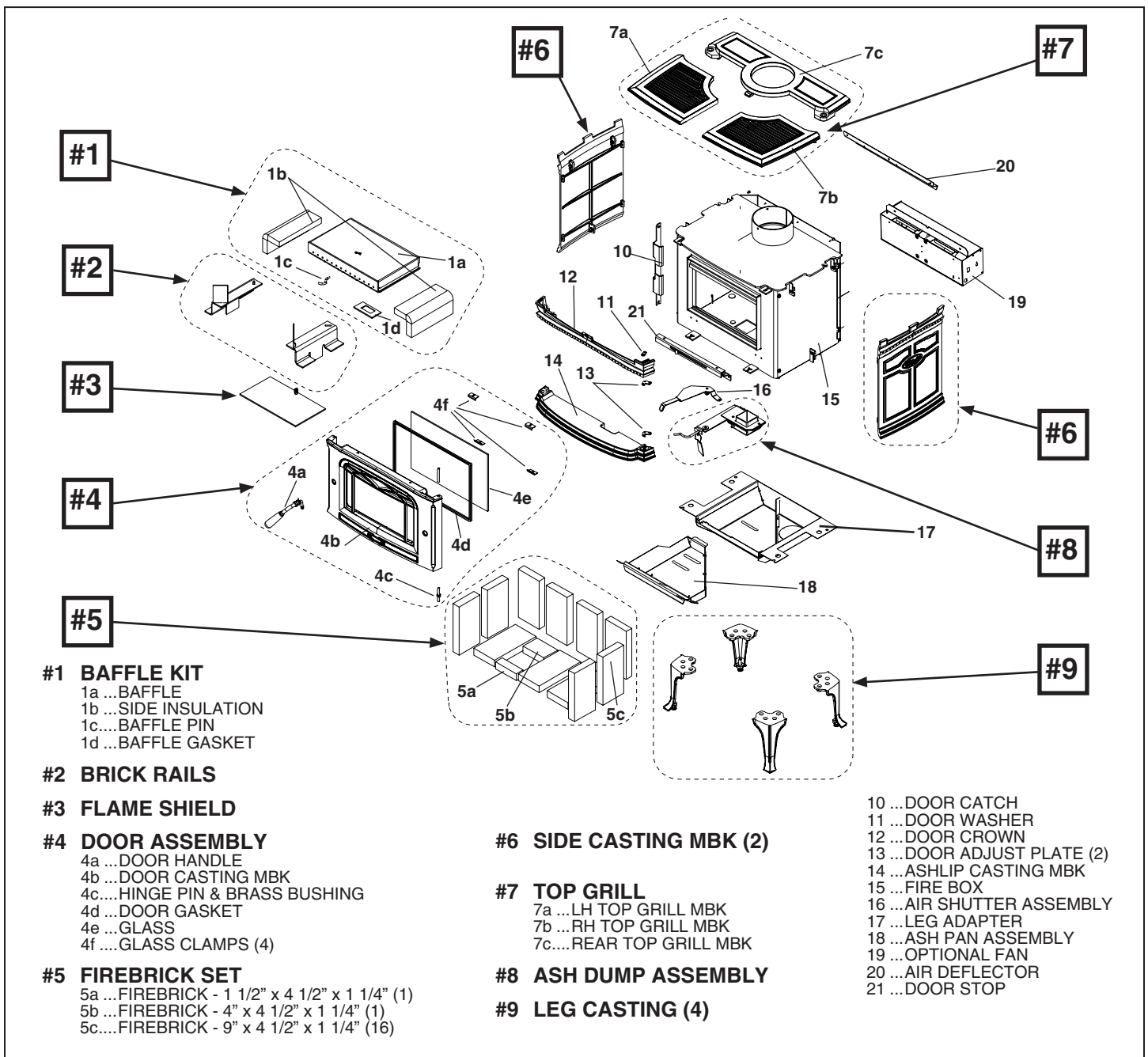

T5 Replacement Parts

#1	BAFFLE KIT	SSER.DBAKIT
#2	BRICK RAILS SET	SSER.RAILSET
#3	FLAME SHIELD	SSER.4115
#4	DOOR ASSEMBLY	ALT5.4700MBK
#5	FIREBRICK SET	BRIC.SSERA
#6	SIDE CASTING MBK (2).....	ALT6.4805MBK
#7	TOP GRILL ASSEMBLY (3)	ALT5.TGASSYMBK
#8	ASH DUMP ASSEMBLY	ALDR.4731
#9	LEG CASTING (4).....	ALDR.4807MBK

ALL OTHER PARTS NOT INCLUDED IN ABOVE KITS ARE NOT SOLD SEPARATELY

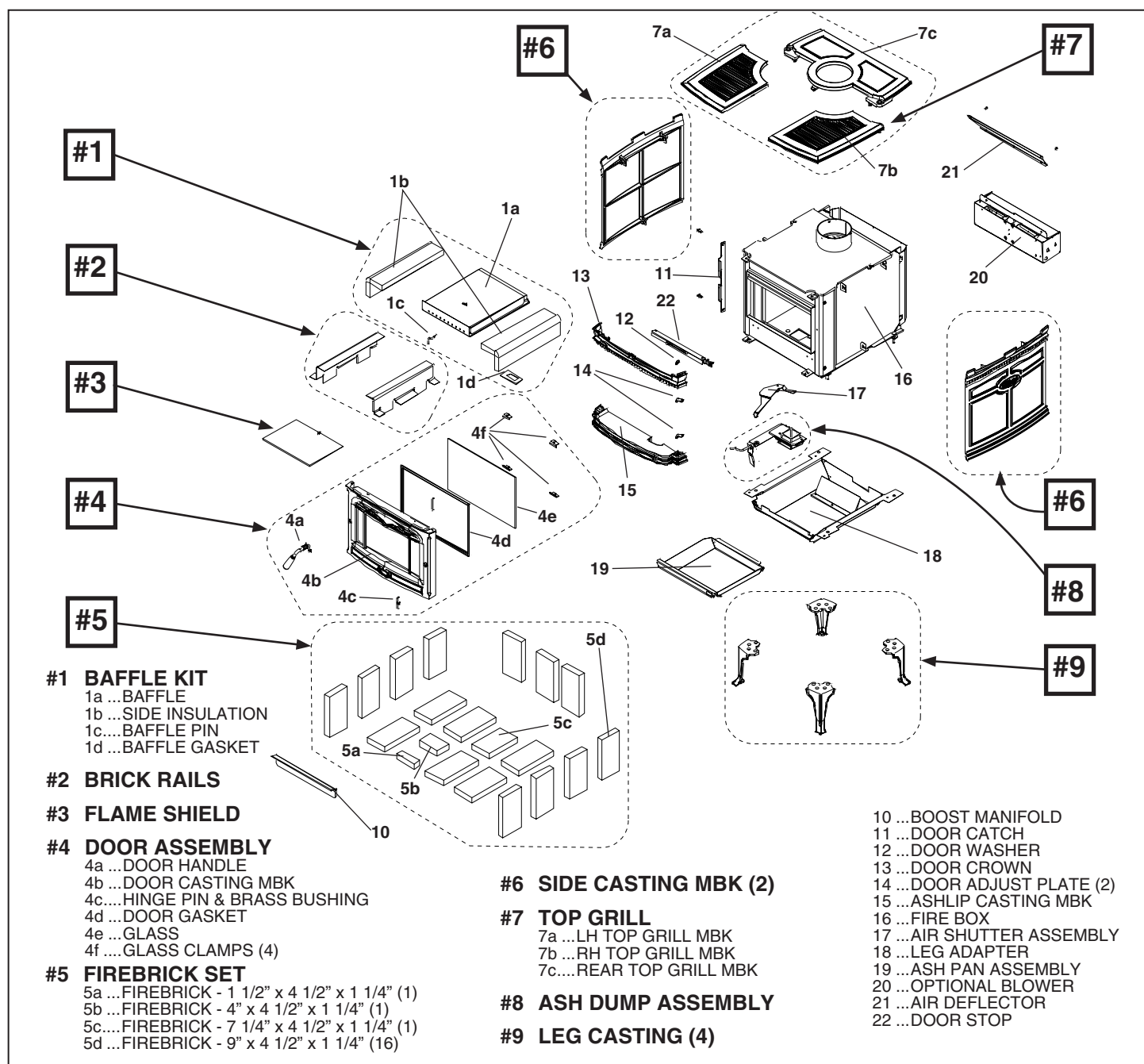

T6 Replacement Parts

- #1 BAFFLE KIT SUMM.BAFKIT
- #2 BRICK RAILS (2) SUMM.RAILSET
- #3 FLAME SHIELD SUMM.3155
- #4 DOOR ASSEMBLY ALTS6.4800MBK
- #5 FIREBRICK SET BRIC.SUMMA
- #6 SIDE CASTING MBK (2) ALTS6.4805MBK
- #7 TOP GRILL ASSEMBLY (3)ALT6.TGASSYMBK
- #8 ASH DUMP ASSEMBLY ALDR.4731
- #9 LEG CASTING (4) ALDR.4807MBK

ALL OTHER PARTS NOT INCLUDED IN ABOVE KITS ARE NOT SOLD SEPARATELY

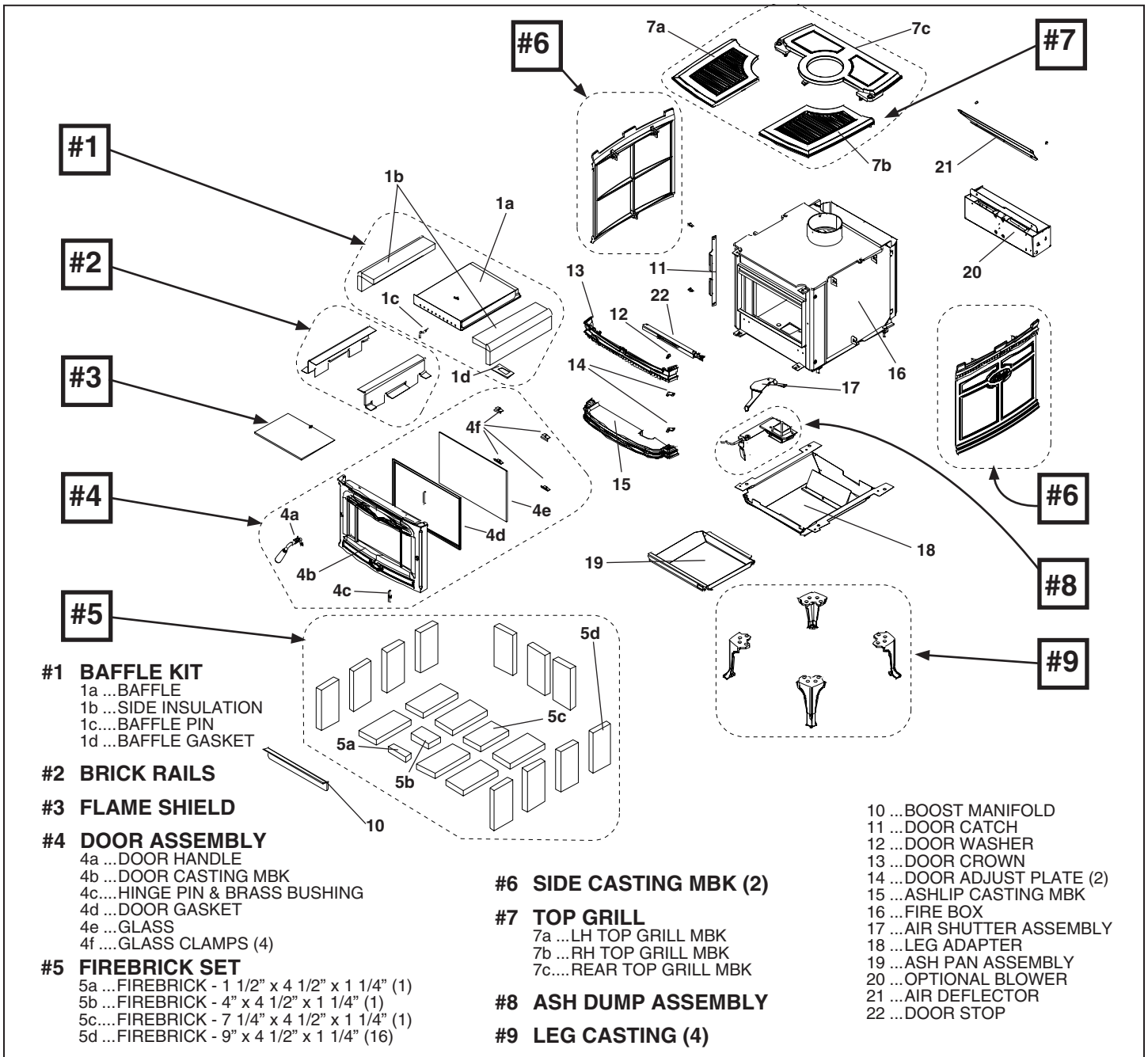

T4 Firebrick Installation Instructions

This package contains 12 full-size firebricks, as well as 2 various cut bricks. If your heater came with an ash cleanout system, or an optional one is being installed, discard one full-size brick.

With the heater in the upright position, install firebricks as follows:

1. Install 4 full-size firebricks against the rear wall.
2. Install the side firebricks, 2 full-size each side.
3. Place 4 full-size on the bottom of the heater.

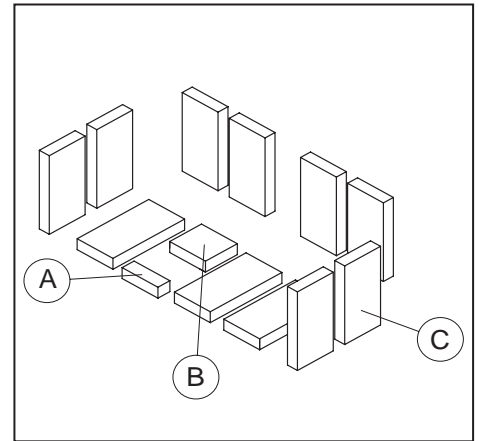

ITEM	SIZE
A	1 1/2" X 4 1/2" X 1 1/4" B
	4" X 4 1/2" X 1 1/4"
C	9" X 4 1/2" X 1 1/4"

T5 Firebrick Installation Instructions

This package contains 18 full-size firebricks, as well as 3 various cut bricks.

With the woodstove in the upright position, install firebricks as follows:

1. Place firebricks on the bottom of the unit first. Use a total of 6 full (D) and 3 cut bricks (A, B & C)
2. Install 4 full-size bricks on each side of the firebox as shown.
3. Install 3 full-size firebricks against the rear wall.

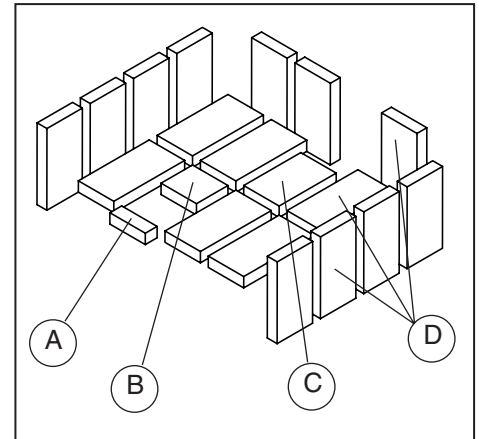

ITEM	SIZE
A	1 1/2" X 4 1/2" X 1 1/4" B
	4" X 4 1/2" X 1 1/4"
C	7 1/4" X 4 1/2" X 1 1/4" D
	9" X 4 1/2" X 1 1/4"

T6 Firebrick Installation Instructions

This package contains 19 full-size firebricks, as well as 5 various cut bricks.

With the woodstove in the upright position, install firebricks as follows:

1. Place the firebricks on the bottom of the unit first. Use a total of 8 full-size (D) and 3 cut bricks (A, B, C).
2. Install 4 full-size firebricks against the rear wall as shown.
3. Install the side firebricks, 3 full-size bricks and one cut brick (E) on each side of the firebox as shown.

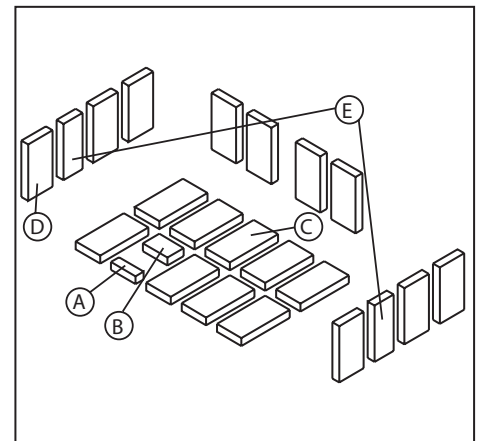

ITEM	SIZE
A	1 1/2" X 4 1/2" X 1 1/4"
B	4" X 4 1/2" X 1 1/4"
C	7 1/4" X 4 1/2" X 1 1/4"
D	9" X 4 1/2" X 1 1/4"
E	9" X 3 1/2" X 1 1/4"

Label T4



**CERTIFIED FOR CANADA AND U.S.A.
LISTED ROOM HEATER, SOLID FUEL TYPE.
ALSO FOR USE IN MOBILE HOMES**

DO NOT REMOVE THIS LABEL

WH-

TESTED TO CAN/ULC S627-M93 AND UL 1482-98 REPORT NO. 6680 (AUG. 89) SERIES: C MODEL: VISTA CLASSIC ALDERLEA T4

- INSTALL AND USE IN ACCORDANCE WITH THE MANUFACTURER'S INSTALLATION AND OPERATING INSTRUCTIONS.
- CONTACT LOCAL BUILDING OR FIRE OFFICIALS ABOUT RESTRICTIONS, INSTALLATION PERMIT AND INSPECTION IN YOUR AREA.
- DO NOT CONNECT THIS UNIT TO A CHIMNEY FLUE SERVING ANOTHER APPLIANCE (USA. ONLY).
- USE 6 INCH / 150MM DIAMETER MINIMUM 24 MSG BLACK OR LISTED CONNECTOR.
- CONNECT TO A LINED MASONRY CHIMNEY SUITABLE FOR USE WITH SOLID FUELS.
- DO NOT OBSTRUCT THE SPACE BENEATH THE HEATER.
- SEE LOCAL BUILDING CODE AND MANUFACTURER'S INSTRUCTIONS FOR PRECAUTIONS REQUIRED WHEN PASSING A CHIMNEY THROUGH A COMBUSTIBLE WALL OR CEILING.
- DO NOT PASS A CHIMNEY CONNECTOR THROUGH A COMBUSTIBLE WALL OR CEILING.
- MINIMUM CLEARANCE BETWEEN SINGLE WALL CHIMNEY CONNECTOR AND COMBUSTIBLE MATERIALS-18INCHES/ 455MM. CLEARANCE MAY BE REDUCED BY THE USE OF LISTED PIPE SHIELDS, WALL PROTECTORS OR OTHER

	RESIDENTIAL INSTALLATION USING SINGLE WALL CONNECTOR		RESIDENTIAL CLOSE CLEARANCE INSTALLATION USING DOUBLE WALL CONNECTOR		* ALCOVE INSTALLATION USING DOUBLE WALL CONNECTOR	MOBILE HOME INSTALLATION USING DOUBLE WALL CONNECTOR
	VERTICAL CONNECTOR	HORIZONTAL CONNECTOR	VERTICAL CONNECTOR	HORIZONTAL CONNECTOR		
A. SIDEWALL TO UNIT	14 IN. / 355 MM	14 IN. / 355 MM	12 IN. / 305 MM	12 IN. / 305 MM	12 IN. / 305 MM	12 IN. / 305 MM
B. BACKWALL TO UNIT	15 IN. / 381 MM	13 IN. / 330 MM	7 IN. / 178 MM	7 IN. / 178 MM	11 IN. / 279 MM	12 IN. / 305 MM
C. CORNER TO UNIT	10 IN. / 254 MM	10 IN. / 254 MM	3 IN. / 76 MM	3 IN. / 76 MM	N/A	8 IN. / 203 MM
D. SIDEWALL TO CONNECTOR	23 IN. / 585 MM	23 IN. / 585 MM	20.5 IN. / 521 MM	20.5 IN. / 521 MM	20.5 IN. / 521 MM	20.5 IN. / 521 MM
E. BACKWALL TO CONNECTOR	18 IN. / 457 MM	16 IN. / 406 MM	9.5 IN. / 241 MM	9.5 IN. / 241 MM	13.5 IN. / 343 MM	14.5 IN. / 370 MM
F. CORNER TO CONNECTOR	19 IN. / 483 MM	19 IN. / 483 MM	11.5 IN. / 292 MM	11.5 IN. / 292 MM	N/A	16.5 IN. / 419 MM

- MEANS APPROVED BY LOCAL BUILDING OR FIRE OFFICIALS.
HORIZONTAL CONNECTOR NOT PERMITTED IN MOBILE HOMES.
‡ AS TESTED - PIPE SHIELD MAY BE REQUIRED BY LOCAL AUTHORITIES.
* COMBUSTIBLE ALCOVE SIZE : DEPTH - 3 FT. / .91 M MAX., HEIGHT 7 FT. / 2.1 M MIN., WIDTH 4 FT. / 1.2 M MIN.
COMBUSTIBLE FLOOR MUST BE PROTECTED BY A CONTINUOUS NON-COMBUSTIBLE MATERIAL EXTENDED TO THE FRONT, SIDES AND BACK AS INDICATED.

- IN CANADA** G. 18 INCHES / 455 MM
H. 8 INCHES / 200 MM
I. 8 INCHES / 200 MM
- IN U.S.A.** G. 16 INCHES / 405 MM
H. 4 INCHES / 102 MM
I. 0 INCHES / 0 MM

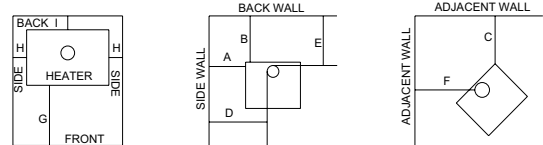

- COMPONENTS REQUIRED FOR MOBILE HOME AND ALCOVE INSTALLATION: OUTSIDE AIR KIT, AND ONE OF THE FOLLOWING LISTED CONNECTORS: SECURITY MODELS DP OR DC, OLIVER MACLEOD MODEL PV, RYDER MODEL E VENT, SELKIRK METALBESTOS MODEL DS, METAL FAB MODEL DW, AMERI-TEC MODEL DBSP, INDUSTRIAL CHIMNEY MODEL EXCEL ULTRA-BLACK, OR SIMPSON DURA-VENT MODEL DVL IN COMBINATION WITH ONE OF THE FOLLOWING COMPATIBLE CHIMNEY SYSTEMS:
- IN CANADA - SECURITY MODEL S2100, OLIVER MACLEOD PROJET MODEL HT 3000, SELKIRK SENTINEL MODEL CF, INDUSTRIAL CHIMNEY MODEL EXCEL 2100, ENERGY VENT COMMANDER 5000.
- IN USA - SECURITY MODEL ASHT OR S2100, OLIVER MACLEOD MODEL 3103 OR HT 3000, SELKIRK METALBESTOS MODEL SS II, METAL FAB MODEL 2100, AMERI-TEC MODEL HS, INDUSTRIAL CHIMNEY MODEL EXCEL 103HT, SIMPSON DURA-VENT MODEL DURA/PLUS AND DURA TECH.
- USE COMPONENTS SPECIFIED IN PACIFIC ENERGY INSTALLATION INSTRUCTIONS.
- APPLIANCE MUST BE INSTALLED WITH PEDESTAL OR LEG KIT ATTACHED.
- OPTIONAL COMPONENTS - FAN KIT, FAN ELECTRICAL RATING: 115V, 60HZ, 80WATTS.
- DO NOT ROUTE POWER CORD BENEATH HEATER.
- CAUTION: RISK OF EXCESSIVE TEMPERATURES - KEEP ASH DUMP CLOSED DURING FIRING OF THE HEATER.
- OPERATE ONLY WITH FEED DOOR CLOSED. OPEN TO FEED FIRE ONLY.
- KEEP FURNISHINGS AND OTHER COMBUSTIBLE MATERIALS WELL AWAY FROM HEATER.
- REPLACE GLASS ONLY WITH CERAMIC GLASS.



CANADA'S FINEST STOVES
MANUFACTURED BY:
PACIFIC ENERGY FIREPLACE PRODUCTS LTD.
2975 ALLENBY RD., DUNCAN, BC V9L 6V8



CAUTION

HOT WHILE IN OPERATION. DO NOT TOUCH. KEEP CHILDREN, CLOTHING AND FURNITURE AWAY. CONTACT MAY CAUSE SKIN BURNS. SEE NAMEPLATE AND INSTRUCTIONS.

U.S. ENVIRONMENTAL PROTECTION AGENCY CERTIFIED TO COMPLY WITH JULY, 1990, PARTICULATE EMISSION STANDARDS

DATE OF MANUFACTURE

J	F	M	A	M	J	J	A	S	O	N	D
2004	2005	2006	2007	2008	2009						

MADE IN CANADA

130307

5050.73

VST1-C-1a



Label T5



CERTIFIED FOR CANADA AND U.S.A.
LISTED ROOM HEATER, SOLID FUEL TYPE.
ALSO FOR USE IN MOBILE HOMES
TESTED TO CAN/ULC S627-M93 AND UL 1482-98

DO NOT REMOVE THIS LABEL

WH-

ALDERLEA T5

MODEL SERIES D: ■ SUPER 27 ■ SPECTRUM ■ CLASSIC

- INSTALL AND USE IN ACCORDANCE WITH THE MANUFACTURER'S INSTALLATION AND OPERATING INSTRUCTIONS.
- CONTACT LOCAL BUILDING OR FIRE OFFICIALS ABOUT RESTRICTIONS, INSTALLATION PERMIT AND INSPECTION IN YOUR AREA.
- DO NOT CONNECT THIS UNIT TO A CHIMNEY FLUE SERVING ANOTHER APPLIANCE (USA. ONLY).
- USE 6 INCH / 150MM DIAMETER MINIMUM 24 MSG BLACK OR LISTED CONNECTOR.
- CONNECT TO A LINED MASONRY CHIMNEY SUITABLE FOR USE WITH SOLID FUELS.
- DO NOT OBSTRUCT THE SPACE BENEATH THE HEATER.
- SEE LOCAL BUILDING CODE AND MANUFACTURER'S INSTRUCTIONS FOR PRECAUTIONS REQUIRED WHEN PASSING A CHIMNEY THROUGH A COMBUSTIBLE WALL OR CEILING.
- DO NOT PASS A CHIMNEY CONNECTOR THROUGH A COMBUSTIBLE WALL OR CEILING.
- MINIMUM CLEARANCE BETWEEN SINGLE WALL CHIMNEY CONNECTOR AND COMBUSTIBLE MATERIALS-18INCHES/ 455MM. CLEARANCE MAY BE REDUCED BY THE USE OF LISTED PIPE SHIELDS, WALL PROTECTORS OR OTHER MEANS APPROVED BY LOCAL BUILDING OR FIRE OFFICIALS.

MINIMUM CLEARANCES TO COMBUSTIBLE MATERIALS

	RESIDENTIAL INSTALLATION USING SINGLE WALL CONNECTOR		RESIDENTIAL CLOSE CLEARANCE INSTALLATION USING DOUBLE WALL CONNECTOR		* ALCOVE INSTALLATION USING DOUBLE WALL CONNECTOR	MOBILE HOME INSTALLATION USING DOUBLE WALL CONNECTOR
	VERTICAL CONNECTOR	HORIZONTAL CONNECTOR	VERTICAL CONNECTOR	HORIZONTAL CONNECTOR		
A. SIDEWALL TO UNIT	18 in. / 455 mm	14 in. / 355 mm	14 in. / 355 mm	14 in. / 405 mm	16 in. / 405 mm	16 in. / 405 mm
B. BACKWALL TO UNIT	12 in. / 305 mm	8 in. / 200 mm	5 in. / 127 mm	5 in. / 127 mm	10 in. / 255 mm	8 in. / 200 mm
C. CORNER TO UNIT	11 in. / 280 mm	11 in. / 280 mm	4 in. / 102 mm	4 in. / 102 mm	N/A	8 in. / 200 mm
D. SIDEWALL TO CONNECTOR	27 in. / 685 mm	23 in. / 585 mm	22.5 in. / 570 mm	22.5 in. / 570 mm	24.5 in. / 620 mm	24.5 in. / 620 mm
E. BACKWALL TO CONNECTOR	19 in. / 485 mm	15 in. / 380 mm	11.5 in. / 292 mm	11.5 in. / 292 mm	16.5 in. / 420 mm	14.5 in. / 370 mm
F. CORNER TO CONNECTOR	22 in. / 560 mm	22 in. / 560 mm	14.5 in. / 370 mm	14.5 in. / 370 mm	N/A	18.5 in. / 470 mm

HORIZONTAL CONNECTOR NOT PERMITTED IN MOBILE HOMES

⚡ AS TESTED - PIPE SHIELD MAY BE REQUIRED BY LOCAL AUTHORITIES.

* COMBUSTIBLE ALCOVE SIZE : DEPTH - 4 FT. / 1.22 M MAXIMUM, HEIGHT 7 1/2 FT. / 2.3 M MINIMUM

COMBUSTIBLE FLOOR MUST BE PROTECTED BY A CONTINUOUS NON-COMBUSTIBLE MATERIAL EXTENDED TO THE FRONT, SIDES AND BACK AS INDICATED.

IN CANADA G. 18 INCHES / 455 MM
 H. 8 INCHES / 200 MM
 I. 8 INCHES / 200 MM

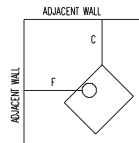
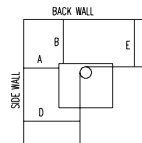
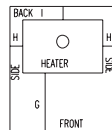

IN U.S.A. G. 16 INCHES / 405 MM
 H. 5 INCHES / 127 MM
 I. 0 INCHES / 0 MM

- COMPONENTS REQUIRED FOR MOBILE HOME AND ALCOVE INSTALLATION: OUTSIDE AIR KIT, AND ONE OF THE FOLLOWING LISTED CONNECTORS: SECURITY MODELS DP OR DC, OLIVER MACLEOD MODEL PV, ENERGY VENT E VENT, SELKIRK METALBESTOS MODEL DS, METAL FAB MODEL DW, AMERI-TEC MODEL DBSP, INDUSTRIAL CHIMNEY MODEL EXCEL ULTRA-BLACK, OR SIMPSON DURA-VENT MODEL DVL IN COMBINATION WITH ONE OF THE FOLLOWING COMPATIBLE CHIMNEY SYSTEMS: APPLIANCE MUST BE INSTALLED WITH PEDESTAL OR LEG KIT ATTACHED.

IN CANADA - SECURITY MODEL S2100, OLIVER MACLEOD PROJET MODEL HT 3000, SELKIRK SENTINEL MODEL CF, INDUSTRIAL CHIMNEY MODEL EXCEL 2100.

IN USA - SECURITY MODEL ASHT OR S2100, OLIVER MACLEOD MODEL 3103 OR HT 3000, SELKIRK METALBESTOS MODEL SS II, METAL FAB MODEL 2100, AMERI-TEC MODEL HS, INDUSTRIAL CHIMNEY MODEL EXCEL 103HT, SIMPSON DURA-VENT MODEL DURA/PLUS AND DURA TECH.

USE COMPONENTS SPECIFIED IN PACIFIC ENERGY INSTALLATION INSTRUCTIONS.

- OPTIONAL COMPONENTS - WATER COIL (CANADA ONLY), FAN KIT #WODC.BLOW,FAN ELECTRICAL RATING: 115V, 60HZ, 80WATTS. DO NOT ROUTE POWER CORD BENEATH HEATER.
- CAUTION: RISK OF EXCESSIVE TEMPERATURES - KEEP ASH DUMP CLOSED DURING FIRING OF THE HEATER.
- OPERATE ONLY WITH FEED DOOR CLOSED. OPEN TO FEED FIRE ONLY.
- KEEP FURNISHINGS AND OTHER COMBUSTIBLE MATERIALS WELL AWAY FROM HEATER.
- REPLACE GLASS ONLY WITH CERAMIC GLASS.



CANADA'S FINEST STOVES

MANUFACTURED BY:
 PACIFIC ENERGY FIREPLACE PRODUCTS LTD.
 2975 ALLENBY RD., DUNCAN, BC V9L 6V8

CAUTION

HOT WHILE IN OPERATION. DO NOT TOUCH. KEEP CHILDREN, CLOTHING AND FURNITURE AWAY. CONTACT MAY CAUSE SKIN BURNS. SEE NAMEPLATE AND INSTRUCTIONS.

U.S. ENVIRONMENTAL PROTECTION AGENCY
 CERTIFIED TO COMPLY WITH
 JULY, 1990, PARTICULATE
 EMISSION STANDARDS

DATE OF MANUFACTURE

J	F	M	A	M	J	J	A	S	O	N	D
2004	2005	2006	2007	2008	2009						

MADE IN CANADA

130307 5050.75

SUP1-A2



Label T6



CERTIFIED FOR CANADA AND U.S.A.
LISTED ROOM HEATER, SOLID FUEL TYPE.
ALSO FOR USE IN MOBILE HOMES
TESTED TO ULC S627-M93 AND UL 1482-1998

DO NOT REMOVE THIS LABEL

WH-
ALDERLEA T6
MODEL: PACIFIC SUMMIT

REPORT NO. 476-1491-00 (MAR 98) **SERIES: A**

- INSTALL AND USE IN ACCORDANCE WITH THE MANUFACTURER'S INSTALLATION AND OPERATING INSTRUCTIONS.
- CONTACT LOCAL BUILDING OR FIRE OFFICIALS ABOUT RESTRICTIONS, INSTALLATION PERMIT AND INSPECTION IN YOUR AREA.
- DO NOT CONNECT THIS UNIT TO A CHIMNEY FLUE SERVING ANOTHER APPLIANCE (USA. ONLY).
- USE 6 INCH / 150MM DIAMETER MINIMUM 24 MSG BLACK OR LISTED CONNECTOR.
- CONNECT TO A LINED MASONRY CHIMNEY SUITABLE FOR USE WITH SOLID FUELS.
- DO NOT OBSTRUCT THE SPACE BENEATH THE HEATER.
- SEE LOCAL BUILDING CODE AND MANUFACTURER'S INSTRUCTIONS FOR PRECAUTIONS REQUIRED WHEN PASSING A CHIMNEY THROUGH A COMBUSTIBLE WALL OR CEILING.
- DO NOT PASS A CHIMNEY CONNECTOR THROUGH A COMBUSTIBLE WALL OR CEILING.
- MINIMUM CLEARANCE BETWEEN SINGLE WALL CHIMNEY CONNECTOR AND COMBUSTIBLE MATERIALS-18INCHES/ 455MM. CLEARANCE MAY BE REDUCED BY THE USE OF LISTED PIPE SHIELDS, WALL PROTECTORS OR OTHER MEANS APPROVED BY LOCAL BUILDING OR FIRE OFFICIALS.

MINIMUM CLEARANCES TO COMBUSTIBLE MATERIALS

	RESIDENTIAL INSTALLATION USING SINGLE WALL CONNECTOR		RESIDENTIAL CLOSE CLEARANCE INSTALLATION USING DOUBLE WALL CONNECTOR		ALCOVE INSTALLATION USING DOUBLE WALL CONNECTOR	MOBILE HOME INSTALLATION USING DOUBLE WALL CONNECTOR
	VERTICAL CONNECTOR	HORIZONTAL CONNECTOR	VERTICAL CONNECTOR	HORIZONTAL CONNECTOR		
A. SIDEWALL TO UNIT	12 in. / 305 mm	12 in. / 305 mm	12 in. / 305 mm	12 in. / 305 mm	15 in. / 381 mm	14 in. / 355 mm
B. BACKWALL TO UNIT	9 in. / 229 mm	10 in. / 254 mm	6 in. / 152 mm	10 in. / 254 mm	9 in. / 229 mm	7 in. / 178 mm
C. CORNER TO UNIT	4 in. / 102 mm	4 in. / 102 mm	4 in. / 102 mm	4 in. / 102 mm	N/A	5 in. / 127 mm
D. SIDEWALL TO CONNECTOR	* 21.8 in. / 554 mm	21.8 in. / 554 mm	21.3 in. / 541 mm	21.3 in. / 541 mm	24.3 in. / 617 mm	23.3 in. / 592 mm
E. BACKWALL TO CONNECTOR	* 14.5 in. / 368 mm	* 15.5 in. / 394 mm	* 11 in. / 279 mm	* 15.5 in. / 394 mm	* 14 in. / 355 mm	* 12 in. / 305 mm
F. CORNER TO CONNECTOR	* 15.8 in. / 401 mm	* 15.8 in. / 401 mm	* 15.3 in. / 389 mm	* 15.3 in. / 389 mm	N/A	16.3 in. / 414 mm

* AS TESTED - PIPE SHIELD MAY BE REQUIRED BY LOCAL AUTHORITIES.

‡ COMBUSTIBLE ALCOVE SIZE : DEPTH - 4 FT. / 1.22 M MAXIMUM, HEIGHT 7 FT. / 2.1 M MINIMUM

COMBUSTIBLE FLOOR MUST BE PROTECTED BY A CONTINUOUS NON-COMBUSTIBLE MATERIAL EXTENDED TO THE FRONT, SIDES AND BACK AS INDICATED.

IN CANADA G. 18 INCHES / 455 MM
 H. 8 INCHES / 200 MM
 I. 8 INCHES / 200 MM

IN U.S.A. G. 16 INCHES / 405 MM
 H. 5 INCHES / 127 MM
 I. 0 INCHES / 0 MM

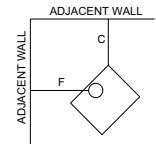
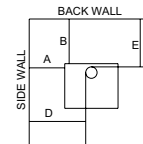
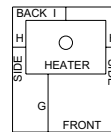

- COMPONENTS REQUIRED FOR MOBILE HOME AND ALCOVE INSTALLATION: OUTSIDE AIR KIT, AND ONE OF THE FOLLOWING LISTED CONNECTORS: SECURITY MODELS DP OR DC, OLIVER MACLEOD MODEL PV, ENERGY VENT MODEL E VENT, SELKIRK METALBESTOS MODEL DS, METAL FAB MODEL DW, AMERI-TEC MODEL DBSP, INDUSTRIAL CHIMNEY MODEL EXCEL ULTRA-BLACK, OR SIMPSON DURA-VENT MODEL DVL IN COMBINATION WITH ONE OF THE FOLLOWING COMPATIBLE CHIMNEY SYSTEMS: APPLIANCE MUST BE INSTALLED WITH PEDESTAL OR LEG KIT ATTACHED.

IN CANADA - SECURITY MODEL S2100, OLIVER MACLEOD PROJET MODEL HT 3000, SELKIRK SENTINEL MODEL CF, INDUSTRIAL CHIMNEY MODEL EXCEL 2100, ENERGY VENT COMMANDER 5000.

IN USA - SECURITY MODEL ASHT OR S2100, OLIVER MACLEOD MODEL 3103 OR HT 3000, SELKIRK METALBESTOS MODEL SS II, METAL FAB MODEL 2100, AMERI-TEC MODEL HS, INDUSTRIAL CHIMNEY MODEL EXCEL 103HT, SIMPSON DURA-VENT MODEL DURA/PLUS AND DURA TECH.

- USE COMPONENTS SPECIFIED IN PACIFIC ENERGY INSTALLATION INSTRUCTIONS.
- OPTIONAL COMPONENTS - FAN KIT #SSER.BLOW, FAN ELECTRICAL RATING: 115V, 60HZ, 80WATTS., FRESH AIR KIT DO NOT ROUTE POWER CORD BENEATH HEATER.
- CAUTION: RISK OF EXCESSIVE TEMPERATURES - KEEP ASH DUMP CLOSED DURING FIRING OF THE HEATER.
- OPERATE ONLY WITH FEED DOOR CLOSED. OPEN TO FEED FIRE ONLY.
- KEEP FURNISHINGS AND OTHER COMBUSTIBLE MATERIALS WELL AWAY FROM HEATER.
- REPLACE GLASS ONLY WITH CERAMIC GLASS.



CANADA'S FINEST STOVES

MANUFACTURED BY:
 PACIFIC ENERGY FIREPLACE PRODUCTS LTD.
 2975 ALLENBY RD., DUNCAN, BC V9L 3Y2



CAUTION

HOT WHILE IN OPERATION. DO NOT TOUCH. KEEP CHILDREN, CLOTHING AND FURNITURE AWAY. CONTACT MAY CAUSE SKIN BURNS. SEE NAMEPLATE AND INSTRUCTIONS.

U.S. ENVIRONMENTAL PROTECTION AGENCY
 CERTIFIED TO COMPLY WITH
 JULY, 1990, PARTICULATE
 EMISSION STANDARDS

DATE OF MANUFACTURE											
J	F	M	A	M	J	J	A	S	O	N	D
2004	2005	2006	2007	2008	2009						

MADE IN CANADA

130307

5050.76

SUMM-A1



Notes



PACIFIC ENERGY FIREPLACE PRODUCTS LTD.

Phone: 1-888-715-2398

Web site: www.pacificenergy.net

2975 Allenby Rd., Duncan, BC V9L 6V8