

# *Appalachian's* *52-Bay*

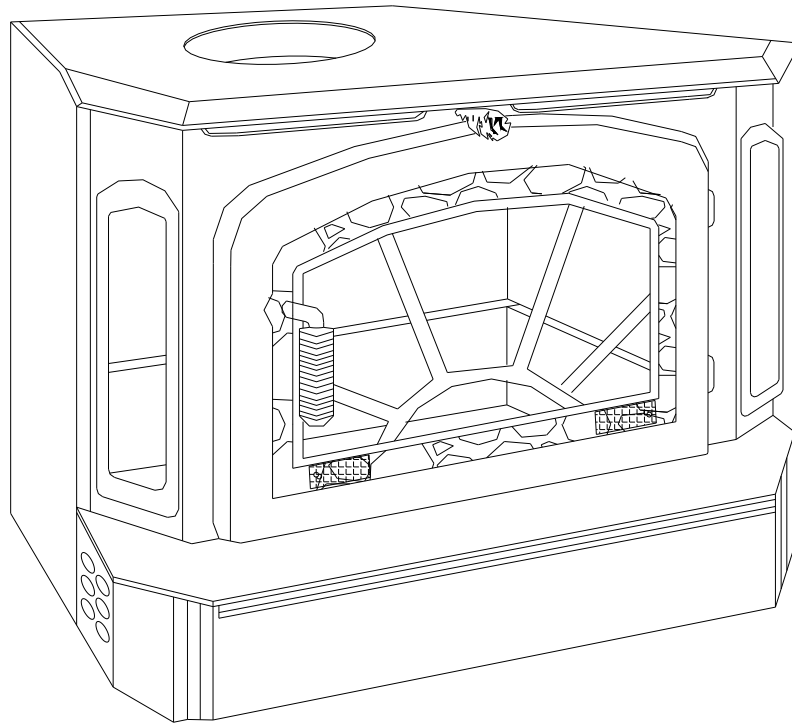

## INSTALLATION AND OPERATION PROCEDURES

FACTORY BUILT FIREPLACE INSERT  
FREESTANDING - RESIDENTIAL  
MOBILE HOME MODELS  
MASONRY FIREPLACE INSERT

© 2001 Appalachian Stove & Fabricators, Inc.

# TABLE OF CONTENTS

I. Stove Features and Operating Controls.....	3	IX. Safety.....	18
II. Fireplace Insert Installation.....	4	X. Limited Warranty.....	18
1. Stove Components.....	4	XI. Warranty Registration.....	19
2. Fireplace Dimensions.....	4		
3. Clearance to Combustibles.....	5		
4. Preparation.....	5		
5. Mounting the Trim Panels.....	5		
6. Installing the Stove.....	6		
7. Importance of Proper Draft.....	6		
III. Freestanding Installation.....	7		
1. Stove Components.....	7		
2. Clearance to Combustibles.....	7		
3. Installing the Stove.....	8		
4. Preparation.....	8		
5. Attaching the Freestanding Base.....	8&9		
6. Attaching the Stove Pipe.....	9		
7. Chimney Installation.....	9		
(A) General.....	9		
(B) Importance of Proper Draft.....	9		
(C) Masonry Flue.....	10		
(D) Factory Built Chimney.....	10		
IV. Installing the Brass Trim.....	11		
V. Installing the Optional Heat Shield.....	12		
VI. Catalytic Combusters.....	13		
1. General Information.....	13		
(A) Tamper Warning.....	13		
(B) Manufacturer and Warranty Info.....	13		
2. Catalyst Monitoring.....	13		
3. Catalyst Troubleshooting General Info.....	14		
4. Catalyst Replacement.....	15		
VII. Stove Operation.....	16		
1. Fuel Selection.....	16		
2. Building and Maintaining a Fire.....	16		
3. Refueling the Stove.....	16		
4. Achieving Catalyst Light-Off			
From a Cold Start.....	16		
5. Catalyst Light-Off When Refueling.....	16		
VIII. Maintenance.....	17		
1. Ash Removal.....	17		
2. Care of the Glass.....	17		
3. Chimney Care.....	17		
4. Stove Finish.....	17		
5. Blower Care.....	17		
6. Door Gasket Replacement.....	17		
7. Motor Maintenance.....	17		

Thank you for purchasing the 52 Bay stove. Appalachian Stove welcomes you to the growing ranks of energy conscious Americans.

Heating with wood and bituminous coal is one way to conserve resources and to stimulate a healthy economy. The forest industry has worked for many years to assure a continual supply of our most abundant renewable resource - wood.

To fully benefit from your stove and to ensure safe operation, follow the instructions in this manual carefully. We hope you enjoy many years of safe, economical heat from your Model 52 Bay stove.

This manual describes the installation and operation of the Appalachian Stove's Model 52-Bay (360-CR) catalytic equipped wood heater. This heater meets the United States Environmental Protection Agency's emission limit for wood heaters sold after July 1, 1988. Under specific conditions, this heater has been shown to deliver heat at rates ranging from 10,000 to 29,000 BTU/hour.

# I. FEATURES AND OPERATING CONTROLS

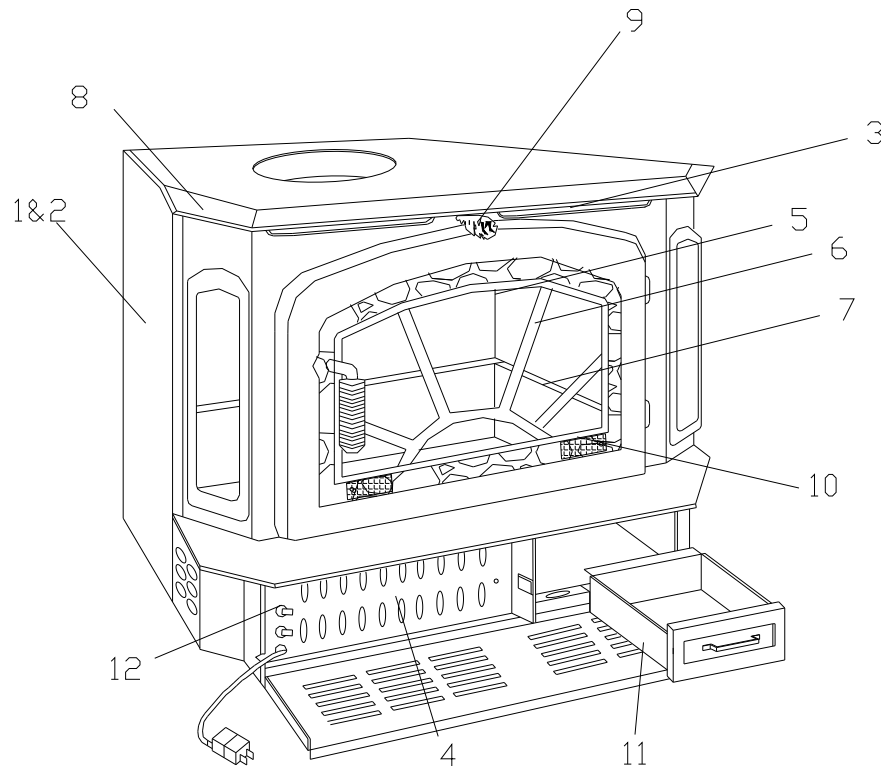

1. Quality steel construction - assures you of years of dependable service. The firebox is constructed of 4 gauge plated steel that is completely welded for safe, durable installation.

2. Double Wall Construction - allows air to flow over all surfaces of the firebox for efficient heat extraction.

3. Warm air outlets - distribute the heated air from around the firebox.

4. Front mounted blower - circulates air around the fire chamber for increased heat extraction. Easy mounting allows for quick access if service is needed.

5. One piece glass door - seals the firebox for high efficiency and allows you to see the fire. The door is available in black or brass.

6. Optional Webbing - Available in black or brass.

7. Refractory firebox liner - boosts burning efficiency by reflecting radiant heat back into the fire. This results in a more thorough and cleaner burn.

8. Warm air deflector - on the top stove edge directs the heated air downward and across the floor for maximum comfort.

9. Sliding damper with catalytics - helps increase heat extraction by controlling the escape of hot combustion gasses and smoke. The damper is opened by pulling the control handle out and closed by pushing the handle in. It may be left in any intermediate position.

10. Draft controls - regulate the burning rate and the heat output of the stove. The larger the fire, the more heat the unit will produce. The drafts are opened by pulling the controls together and may be left in any intermediate position. Start up air (centered under the door) may only be opened during the building of the fire (5 minute max.).

11. Ash pan - for easy removal of ash.

12. Three speed switch - assists in the adjustment of air circulation around the firebox. The automatic position is thermostatically controlled, the blower comes on when the activation temperature is reached. The manual position allows for blower start up at any time.

## II. FIREPLACE INSERT INSTALLATION

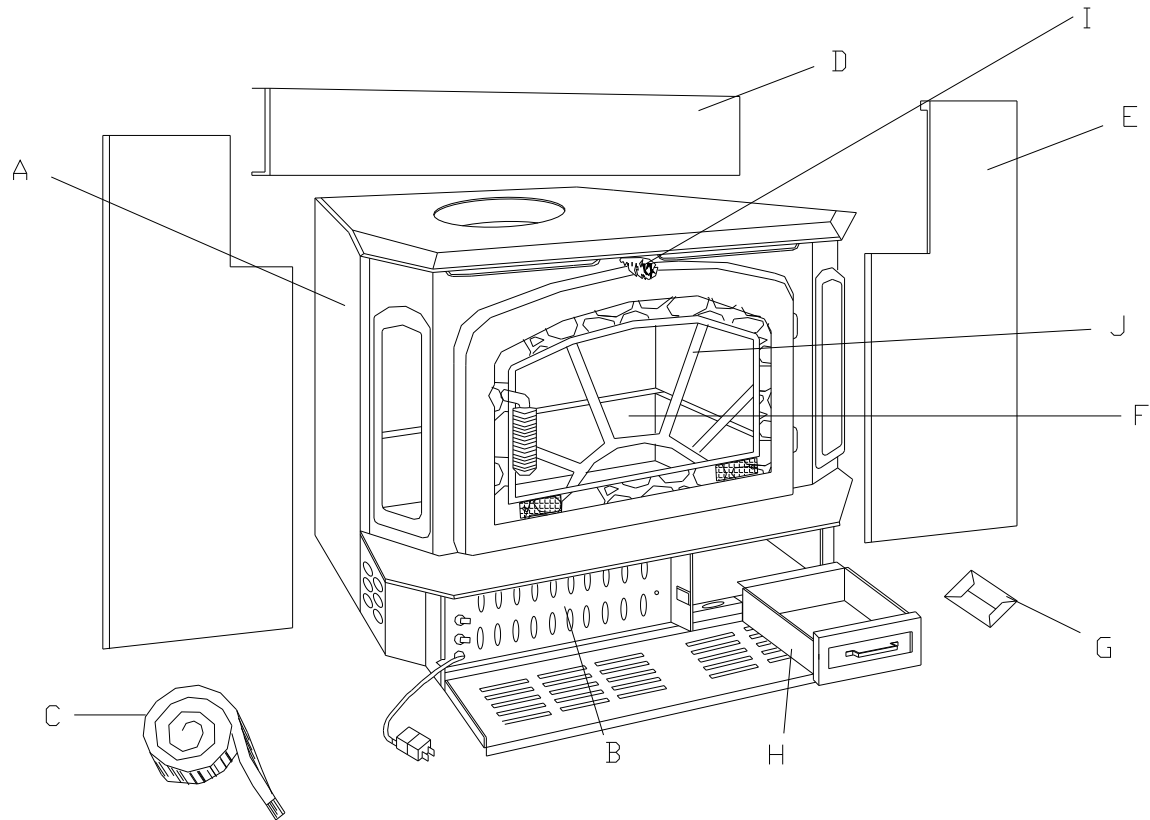

### 1. STOVE COMPONENTS

The following components are included with the 52 Bay Fireplace Insert Model:

- A) 52 Bay Stove
- B) Blower Assembly
- C) Adhesive Backed Insulation
- D) Top Trim Panel (1)
- E) Side Trim Panels (2)
- F) Refractory Firebox Liner
- G) Assembly Screws
- H) Ash Pan
- I) Damper Spring
- J) Optional Webbing

### 2. FIREPLACE DIMENSIONS

Refer to FIGURE 2 to determine the minimum dimensions necessary to install the 52 Bay stove.

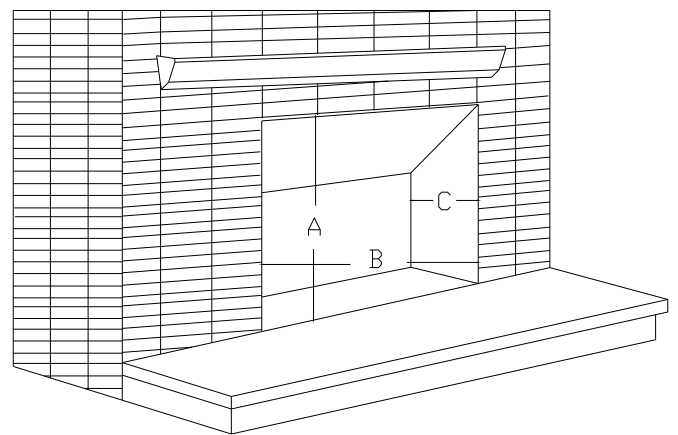

FIGURE 2  
Fireplace Dimensions (Minimum)

A	B	C
23 ½"	33"	14"

\*Depth at height of stove

### 3. CLEARANCE TO COMBUSTIBLES

To ensure a safe installation, the following minimum clearances must be met:

- A) Minimum of 17" from the stove top to the bottom of the combustible mantel.
- B) Minimum of 7" from the side wall of the stove to any combustible.
- C) Minimum of 16" of floor protection in front of the stove (3/8" fireproof millboard or equivalent) for masonry fireplace.
- D) Minimum of 22" of floor protection in front of the stove (3/8" fireproof millboard or equivalent) for factory-built fireplace.

### 4. PREPARATION

To facilitate the installation of your 52 Bay stove, the following steps should be taken before attempting to place the stove in a fireplace.

- A) Clear the area around the fireplace of furniture, rugs, etc. to allow easy access.
- B) Place drop cloths or other protective materials on the floor and hearth to protect against any possible damage.
- C) Remove ashes and thoroughly clean the firebox floor.
- D) Remove the damper plate, if possible, or block it open using non-combustible materials such as a brick or a rock.
- E) Inspect the interior of the firebox and the flue for possible deterioration of mortar joints, loose bricks and excessive creosote buildup.

NOTE: If the flue is dirty, it should be cleaned before installing the stove. If deteriorated, repair or reline the chimney.

### 5. MOUNTING THE TRIM PANELS

- (A) Mount the top trim panel.
- (B) Mount the side trim panels with the mounting screws, provided. (FIGURE 3)

NOTE: If the face of the firebox is rock, or any other rough construction, additional insulation may be needed to properly seal the trim panels.

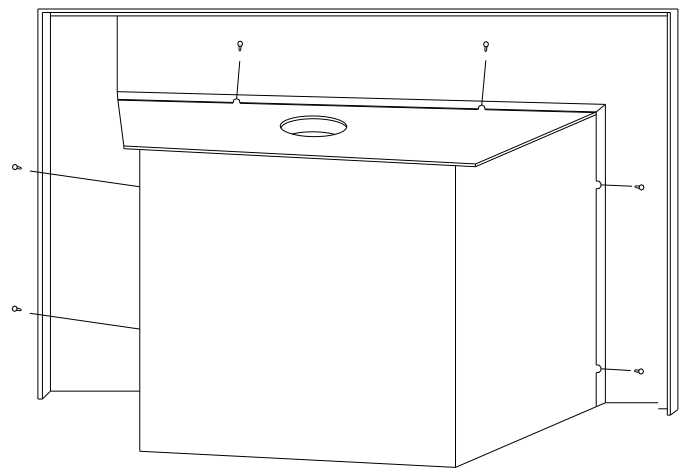

FIGURE 3  
MOUNTING TRIM PANELS

## 6. INSTALLING THE STOVE

A) Slide the stove into the fireplace, centering it within the fireplace opening.

B) Push the stove back until the trim panels seat firmly against the face of the fireplace, compressing the insulation to accomplish a seal.

C) Do not block air inlets on a factory built fireplace.

(D) In a mobile home, the outside air connection of the factory built fireplace **MUST** be connected with the stoves outside air connector.

(E) Be sure to use class A of “HT” pipe

NOTE: Be sure the damper opening of the stove lies behind the lintel to prevent overheating the fireplace facing.

NOTE: If the floor of the fireplace is recessed, it must be built up with non-combustible materials such as brick, scrap metal, etc. The 52 Bay should sit level in the fireplace to function properly.

This completes the installation of your 52 Bay. Please refer to section VII and VIII for instruction on operation and stove maintenance.

## 7. IMPORTANCE OF PROPER DRAFT

Draft is the force which moves air from the appliance up through the chimney. The amount of draft in your chimney depends on the length of the chimney, local geography, nearby obstructions and other factors. Too much draft may lead to excessive temperatures in the appliance and may damage the catalytic combustors. Inadequate draft may cause backpuffing into the room and “plugging” of the chimney catalyst.

NOTE: Inadequate draft will cause the appliance to leak smoke into the room through the appliance and chimney connector joints.

NOTE: An uncontrollable burn or a glowing red stove part or chimney connector indicates excessive draft.

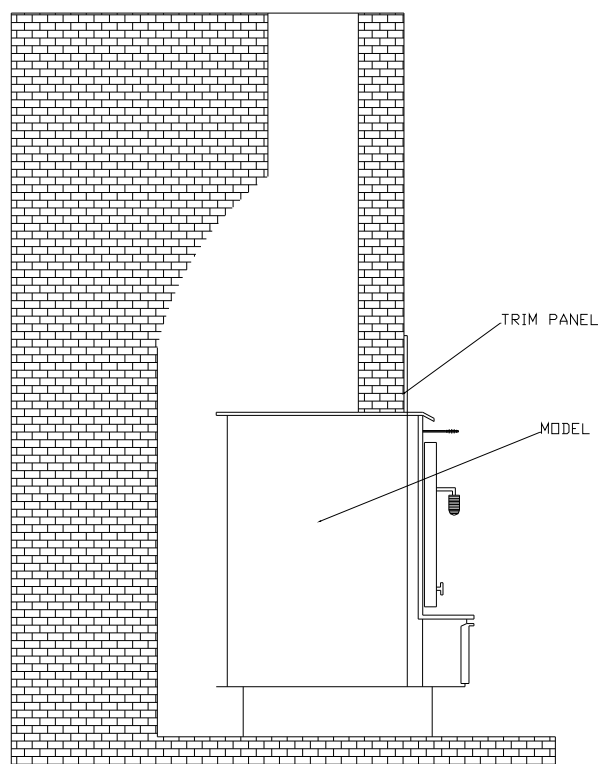

FIGURE 4

## IV. FREESTANDING INSTALLATION

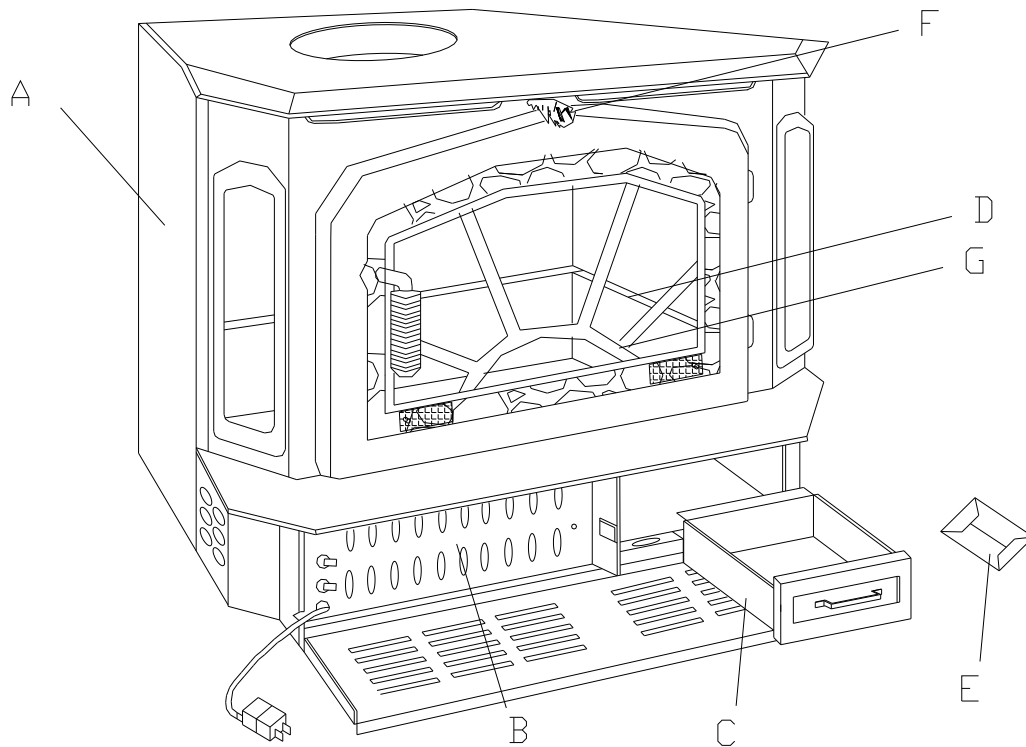

FIGURE 5  
STOVE COMPONENTS

### 1. STOVE COMPONENTS

The following components are included with the 52 Bay Fireplace Insert model:

- A) 52 Bay Stove
- B) Blower Assembly
- C) Ash Pan
- D) Refractory Firebox Liner
- E) Assembly Screws
- F) Damper Spring
- G) Optional Webbing
- H) Pedestal or Brass Legs (4 req) (Not Shown)

### 2. CLEARANCE TO COMBUSTIBLES

The 52 Bay stove must be installed with adequate clearance from combustible surfaces to ensure safe operation. Refer to FIGURE 6 to determine the applicable clearances for your installation.

Rear and side wall clearances depend on two factors:

1. Composition of the wall structure (combustible or non-combustible materials).
2. Type of stove pipe used to connect the stove to the chimney or the flue (single or double wall, insulated pipe).

### 3. INSTALLING THE STOVE

NOTE: Walls or wood frame construction covered with noncombustible veneer, such as brick, are considered COMBUSTIBLE walls.

- A) If the stove is installed on a combustible floor, a protective pad of 3/8" fireproof millboard, or equivalent, must be placed beneath the pedestal. It must extend 8" to either side of the stove and 16" in front of the stove.
- B) If the stove pipe is installed with an elbow to penetrate the wall into a flue, the minimum clearance of the elbow is 18" from the top of the stove pipe and the ceiling.

#### RESIDENTIAL CLEARANCE DIMENSIONS:

	R	S
Combustible Wall-Single Wall Pipe	24"	24"
Combustible Wall-Insulated Pipe	18"	24"
Combustible Wall-Insulated Pipe-Heat Shield	6"	24"
Non-Combustible Wall-Single Wall Pipe	12"	12"
Combustible Wall-Double Wall Air Cooled Pipe with Heat Shield	14"	18"

### 4. PREPARATION

Proper preparation and planning of the installation will simplify the job and help achieve effective operation of the unit.

- A) Select the location of the stove installation. The stove should be positioned so that the air flows to the rest of the home in as straight a line as possible.
- B) Indicate the proper penetration point of the chimney structure. Avoid roof areas such as valleys, ridges, dormers and hips.

Position the floor protector where the installation is to be made (Section II).

Attach the pedestal to the stove and place into position on the floor protector. Check clearances.

### 5. ATTACHING THE FREESTANDING BASE

Tool Needed: Drill

- A) Remove the wooden blocks from the stove bottom. A drill may be used to remove the screws.
- B) PEDESTAL: Position on stove bottom so that it is centered and 2" back from the edge of the stove bottom. The longest solid panel and the opening in the bottom of the pedestal are located at the front of the stove. The pedestal should be placed with the "turned out" flange against the bottom. LEG KIT: There are holes drilled on the bottom of the stove that will line up the legs properly. The legs are attached with screws from the bottom of the stove.

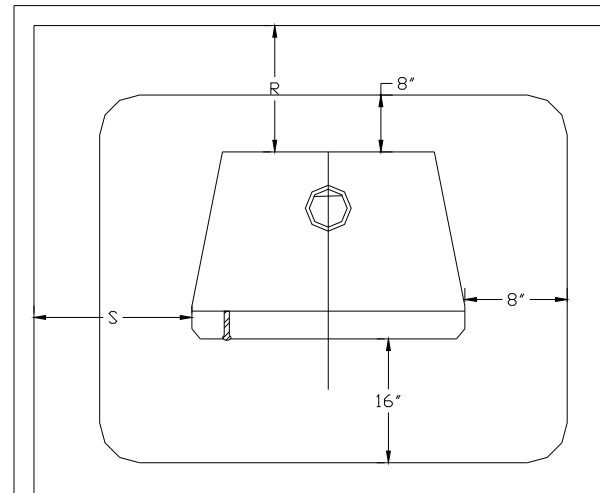

FIGURE 6  
CLEARANCE TO COMBUSTIBLES



NOTE: The vent opening should be completely inside the pedestal.

C) PEDESTAL: Attach using the three (3) drill screws, provided. Drill the holes in the correctly positioned pedestal. The front left corner (blower side of the stove) will not have a screw. The screws will make their own holes in the stove bottom.

## 6. ATTACHING THE STOVE PIPE

Secure the first section of the pipe to the top of the stove using the “L” bracket and screw provided. Place the bracket behind the stove pipe so that one leg rests on the stove top and the other into the pipe to hold the joint firmly together.

## 7. CHIMNEY INSTALLATION

### A) GENERAL

1. The single wall stove pipe used to connect the stove to the flue, whether masonry or factory built, must be a minimum of 24 gauge, blue or black steel.

CAUTION: DO NOT USE GALVANIZED PIPE.

2. Secure every pipe joint with three or more sheet metal screws to prevent accidental separation.

3. If an elbow is installed, the horizontal section of the stove pipe should slope 1/4” per foot to run toward the stove to allow creosote to drip into the firebox and burn.

4. Always install the single wall stove pipe with the male (crimped) end down to prevent leakage of creosote or moisture.

5. The pipe is to be a minimum of 6” inside diameter.

### B) IMPORTANCE OF PROPER DRAFT

Draft is the force which moves air from the appliance up through the chimney. The amount of draft in your chimney depends on the length of the chimney, local geography, nearby obstructions and other factors. Too much draft may lead to excessive temperatures in the appliance and may damage the catalytic combustors. Inadequate draft may cause backpuffing into the room and “plugging” of the chimney catalyst.

NOTE: Inadequate draft will cause the appliance to leak smoke into the room through the appliance and chimney connector joints.

NOTE: An uncontrollable burn or a glowing red stove part or chimney connector indicates excessive draft.

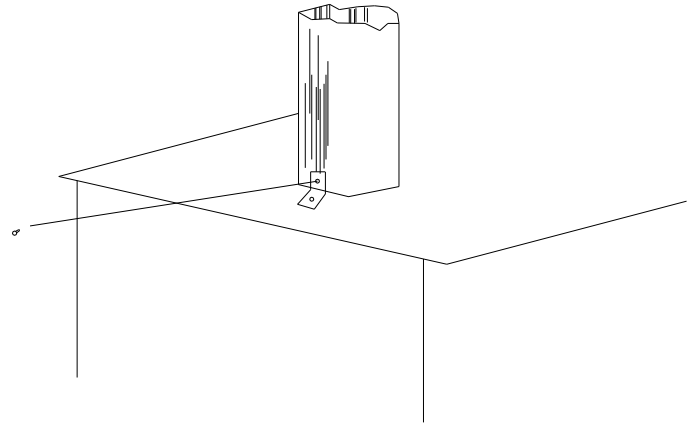

FIGURE 7

### C) INSTALLATION INTO MASONRY FLUE

1. Masonry flues for use with solid fuel appliances must meet the NATIONAL FIRE PROTECTION ASSOCIATIONS CODE 211 specifications.
2. Connection to the masonry flue is made with a masonry or terra-cotta type thimble cemented firmly in place.
3. Material around the thimble connection must provide adequate protection from the fire. Use either 24" of solid masonry or an approved insulated connector.
4. The stove pipe should be inserted far enough into the thimble to assure good connection, but must not extend past the flue lining.
5. Do not use more than one elbow in the stove pipe.
6. Recheck all clearances.

### D) INSTALLATION INTO A FACTORY BUILT CHIMNEY

1. After the stove is positioned, suspend a plumb bob over the center of the damper opening to determine the chimney penetration point.
2. All Appalachian Stoves must be connected ONLY to a UL listed class "HT" all fuel burning heating appliance chimney. CAUTION: SOME CHIMNEYS ARE AVAILABLE WITH UL LISTING WHICH ARE NOT CLASS "HT," AND ARE NOT SAFE WITH A SOLID FUEL APPLIANCE.
3. Install the chimney following the manufacturer's instructions exactly. DO NOT DEVIATE FROM THESE INSTRUCTIONS!
4. The chimney should extend a minimum of 3 feet from the roof structure or 2 feet higher than the highest point within 10 feet, whichever is greater. This assures proper chimney function and reduces the possibility of backdrafts.

NOTE: All installations must meet local building and fire codes. Check with your local building officials for assistance in getting permits, inspections, and good advice.

NOTE: Use of aluminum type B gas vent for solid fuels is unsafe and prohibited by the National Fire Protection Association Code.

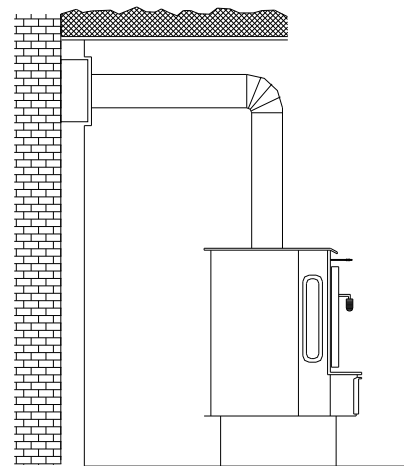

FIGURE 8 - INSTALLATION INTO A MASONRY FLUE

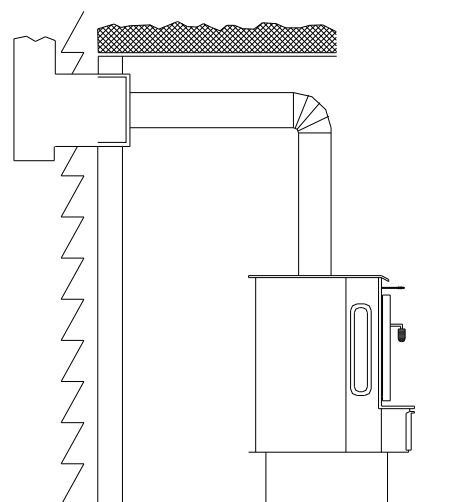
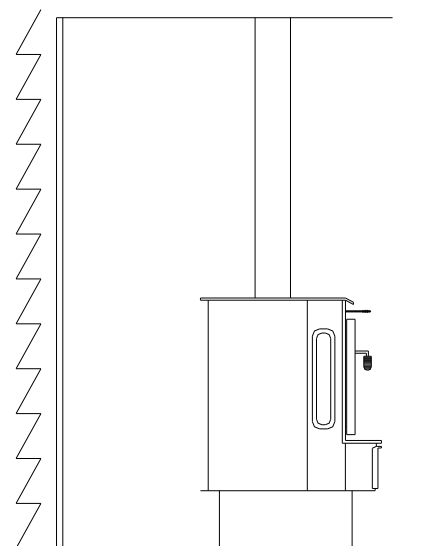

FIGURE 9 - INSTALLATION INTO A FACTORY BUILT CHIMNEY

## V. INSTALLING THE BRASS TRIM

### 1. STANDARD BRASS

(A) Spring damper handle - screw the handle onto the damper rod counter-clockwise.

### 2. OPTIONAL BRASS

#### A) GOLD PLATED DOOR WEBBING/CAST WEBBING

1. For ease of installation, remove the door from the stove. The door can be removed from its hinges with the proper leverage.

2. The air channel can then be taken off by removing the four screws. Remove the glass.

3. Place the webbing in the center of the opening. If the door is cast and the webbing is brass, it may be a tight fit. Make sure that the webbing drops down completely.

NOTE: The door may also be replaced, if desired. It also comes in the option of gold plated or cast black.

#### B) BRASS TRIM PANELS

1. Mount top and side strips to trim panels with the self tapping brass screws that are provided. Leave approximately 1" at top edges of trim to be covered by corner brass. If needed, strips can easily be cut with a hacksaw.

2. Mount two brass corners overlapping top and side brass strips.

3. Remove protective coating from brass strips before use.

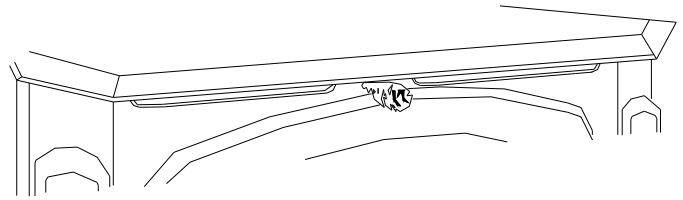

FIGURE 10

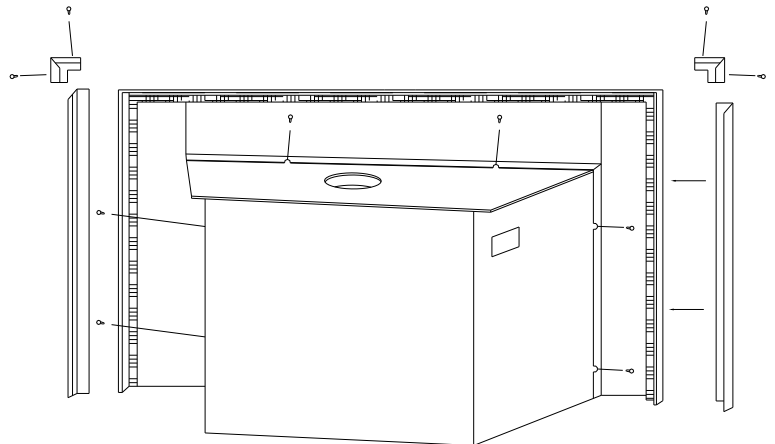
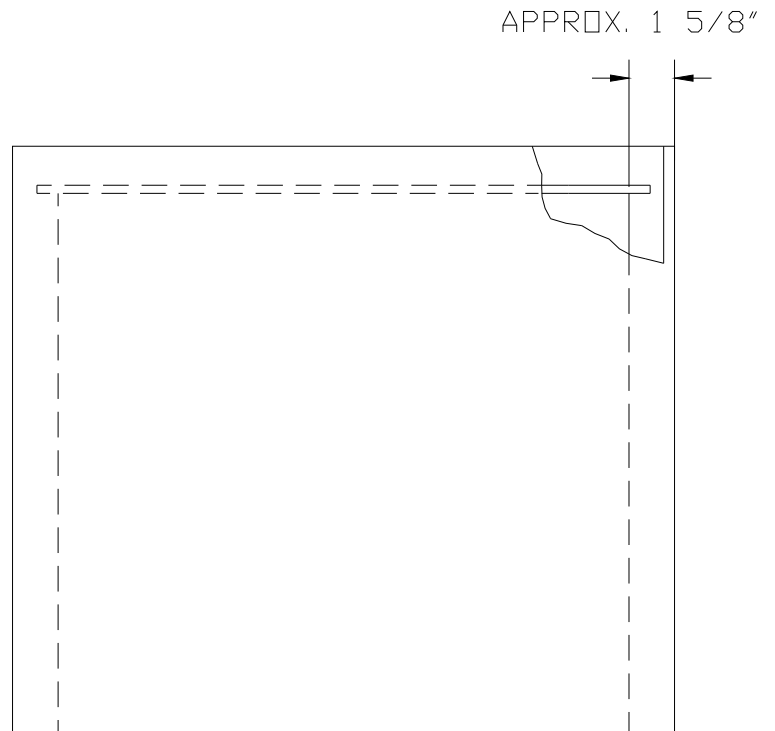

FIGURE 11  
FRONT EDGE BRASS

## VI. INSTALLING THE OPTIONAL HEAT SHIELD

1. Center the heat shield on the back of the stove.



2. Attach the heat shield to the stove using the screws provided. Place the spacer between the heat shield and the stove back. The screw will go through the spacer.

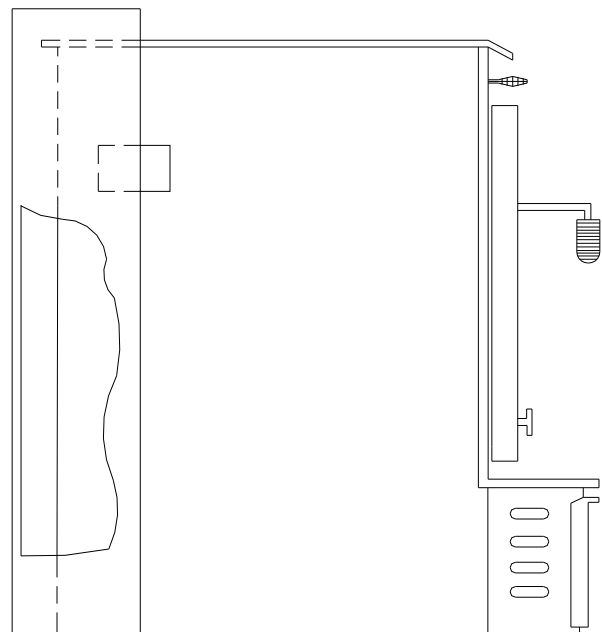
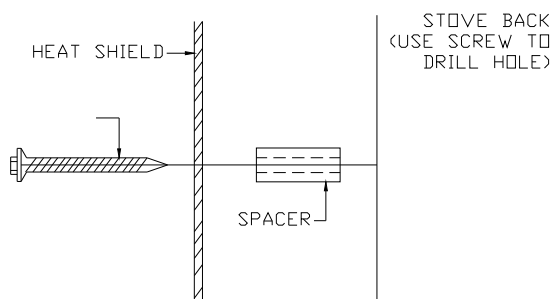

FIGURE 12  
INSTALLING THE HEAT SHIELD

# VII. CATALYTIC COMBUSTORS

## 1. GENERAL INFORMATION

### (A) TAMPER WARNING

This wood heater contains a catalytic combustor, which needs periodic inspection and replacement for proper operation. It is against the law to operate this wood heater in a manner inconsistent with the operating instructions in this manual, or if the catalytic element is deactivated or removed.

### (B) MANUFACTURER AND WARRANTY INFO

The combustors supplied with this heater are Applied Ceramics Versagrid Catalytic Converter. Consult the catalytic combustor warranty also supplied with this heater.

Warranty claims should be addressed to:  
Applied Ceramics - Warranty Department  
P.O. Box 29664  
Atlanta, GA 30359  
(404) 448-6888

Warranty Claims **MUST** have the following items:

1. Warranty Claim Form
2. Dated Proof of Purchase
3. Check for proper amount (including postage and handling)
4. APPLIED CERAMICS Catalytic Combustor

## 2. CATALYST MONITORING

It is important to periodically monitor the operation of the catalytic combustor to ensure that it is functioning properly and to determine when it needs to be replaced. A non-functioning combustor will result in a loss of heating efficiency and an increase in creosote and emissions.

Check these items periodically:

\* Visually inspected combustors at least three times during the heating season to determine if physical degradation has occurred. Actual removal of the combustor is not recommended unless a more detailed inspection is warranted because of a decrease in performance. If any of these conditions exist, refer to the Catalyst Troubleshooting Guide.

\* This catalytic heater may be equipped with a temperature probe to monitor catalyst operation. Proper functioning combustors typically maintain temperatures in excess of 500 degrees Fahrenheit and often reach temperatures in excess of 1000 degrees Fahrenheit. If catalytic temperatures are not in excess of 500 degrees, refer to the Catalyst Troubleshooting Guide or further information located in this manual.

\* To determine if the catalyst is working, compare the amount of smoke leaving the chimney when the smoke is going through the combustor and catalyst light-off has been achieved to the amount of smoke leaving the chimney when the smoke is not routed through the combustor (bypass mode - damper open).

1. Light the stove in accordance with instructions given on how to achieve catalyst light off.
2. With smoke routed through the catalyst, go outside and observe the emissions from the chimney.
3. Engage the bypass mechanism (open the damper) and again observe the emissions leaving the chimney.

Significantly more smoke should be seen when the exhaust is not routed through the combustor (bypass mode - damper open). Be careful not to confuse smoke with steam from wet wood.

The 52 Bay was designed to allow the owner to monitor the catalyst temperatures. A small port is located on the top of the stove, inside the unit. From that port, wires may be led out of the unit to a temperature monitoring device. Some Gemini models have this wiring already done. The port is positioned to allow for temperatures to be taken approximately 1" behind the right catalyst. The thermocouple and monitor should be compatible and should read temperatures to approximately 1800 degrees F.

### Front Mounted Catalytic Probe

Locate screw above the door and to the left of the damper. Remove the screw and insert catalytic probe.

### 3. CATALYST TROUBLESHOOTING

The operation of any wood stove can create problems. While the use of a catalyst equipped wood stove will substantially lessen some of these problems, such as creosote formation, other traditional wood stove problems may remain. These problems are invariable related to such conditions as draft, aging or failure of stove components, flue installation, wood supply and others.

Here are a few clues that may be of some assistance in discerning problems:

A sluggish stove performance may be attributed to: a poor chimney draft; an obstruction in the chimney; the chimney damper being closed; closing the bypass damper too soon; burning wet or unseasoned wood; the combustor being plugged or obstructed, or a combination of the above.

A drop in overall fuel efficiency may be attributed to: having cold, windy weather; burning wet, pithy or spongy wood; the combustor not in operational mode (200-300 plus degrees); or the combustor being broken or dislodged.

A high fuel consumption may be attributed to: burning the wrong type of wood for the desired heat output; improper regulation of draft or inlet air (close damper after proper light off, install barometric damper set to .06 inches of water, or close inlet air as much as possible); cold, windy weather; or the combustor not engaged or functioning properly.

Backpuffing may be attributed to: gusts of wind; a hot combustor (above 1400 degrees F); or opening doors in a tightly constructed house.

Smoke rollout when the door is opened may be attributed to: the manual flue being closed; wind gusts blowing down the chimney; the combustor not at operational temperature, or the stove door being opened too quickly.

Glowing stove parts may be attributed to: running the stove too hot (excessive amounts of wood); a high draft (reduce when temperatures become too excessive); a glowing combustor (this is normal during first 1/3 of burn cycle), or a chimney fire (close inlet air and outlet dampers completely - if this does not help, vacate home and call the fire department immediately).

Creosote accumulation may be caused by one or more of the following: a poorly insulated chimney; a non-functioning combustor; types and amounts of wood burned, or a leaking damper plate.

Creosote leakage from metal flue joints may be caused by one or more of the following: no chimney cap; metal flue assembled improperly, or a normal increase in the moisture due to a higher efficiency of catalytic burning (condensation on cool chimney walls).

A heavy concentration of smoke leaving the chimney may be attributed to one or more of the following: improper wood being burned; the damper being open, or water vapor (on cold, still days, water vapor is often mistaken for smoke. Water vapor appears to be white and tends to rise vertically and dissipate rapidly while smoke is usually bluish brown and drifts down and settles in low areas before dissipating).

A poor draft may be attributed to these factors: an improper chimney height; wrong size flue being used; cooler temperatures caused by external chimney, or a massive stone or masonry chimney.

An unhealthy combustor can be attributed to plugging, catalyst peeling, catalyst deactivation, masking, substrate cracking (thermal and mechanical), substrate crumbling, color variations (does not affect performance), or catalyst abrasion. An excellent guide to pinpointing and correcting these problems can be found by consulting the catalyst warranty.

#### 4. CATALYST REPLACEMENT

To replace damaged or non-functioning catalytics follow these steps:

- A) Loosen the damper tab bolts with 9/16" socket to allow the damper tab to slide back. Lower the cast housing as shown.
- B) Remove the mixing plate, sealing plate and catalyst. Clean the area where the catalyst sits to remove old gasketing. Inside the stove, check the area where the damper system was located and clean away old gasketing, if necessary.
- C) Install the new catalytics. Uncanned catalytics (catalytics not in metal housing) should be wrapped with 1/16" gasketing before installing. Locate the catalytics 1/2" from the front of the damper housing. Re-install the sealing.
- D) New gasketing should be installed to allow for a seal between the damper housing and the firebox top. This may be done by putting a layer of gasketing around the top where the housing is located. In both cases, the use of an adhesive to hold the gasketing in place will make the installation easier.
- E) Remount the cast housing in the back of the stove. Tighten damper tab bolts. Make sure the damper slides easily. Use furnace cement to seal gaps between the sealing plate and the catalytics, the rod guide and the top of the firebox.

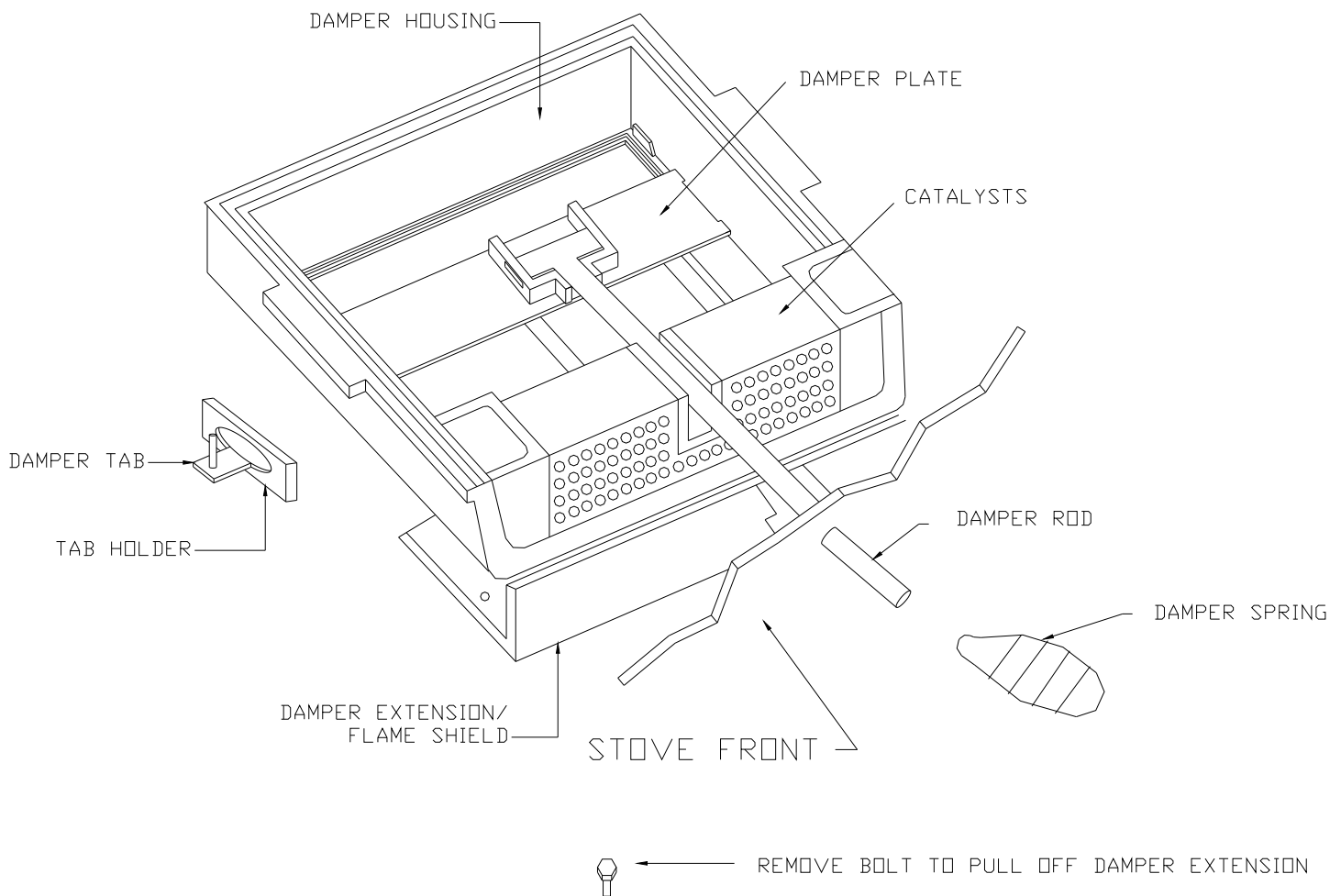



## VIII. OPERATION

---

Proper operation of your 52 Bay stove will help to ensure safe, efficient heating. Review these operating instructions.

### 1. FUEL SELECTION

The 52 Bay is designed to burn natural wood only. Higher efficiencies and lower emissions generally result when burning air dried seasoned hardwoods, as compared to softwoods or to green or freshly cut hardwoods. **DO NOT BURN THE FOLLOWING:** treated wood, coal, garbage, solvents, colored papers, or trash. Burning these may result in the release of toxic fumes and may poison or render the catalytic ineffective. Burning coal, cardboard, or loose paper can produce soot, or large flakes of char or fly ash that can coat the combustor, causing smoke spillage into the room, rendering the combustor ineffective.

### 2. BUILDING AND MAINTAINING A FIRE

(A) Open the damper fully by pulling the damper control panel all the way out.

(B) Place a base of crumpled uncolored newspaper in the bottom of the stove. Lay pieces of kindling on top of the newspaper and light it.

(C) As the kindling begins to burn, add several larger pieces of wood until the fire is burning well. At this point, regular size logs may be added.

NOTE: Until the fire is burning well, leave the draft controls in the door fully open.

**NEVER USE GASOLINE, GASOLINE TYPE LANTERN FUEL, KEROSENE, CHARCOAL, LIGHTER FLUID, OR SIMILAR LIQUIDS TO START OR "FRESHEN UP" A FIRE IN THIS HEATER. KEEP ALL SUCH LIQUIDS FAR AWAY FROM THIS HEATER WHILE IN USE.**

(D) For a stove equipped with a catalytic combustor, the damper must be fully closed after the fire is burning well.

(E) Regulate the heat output of the stove by adjusting the draft controls to allow a larger fire and vice versa. A short period of experimentation with the control settings will allow you to regulate the heat output to keep your home comfortable.

**CAUTION: DO NOT UNPLUG YOUR BLOWER WHILE THE STOVE IS IN OPERATION.**

**CAUTION: THE ASH PAN DRAWER MUST BE CLOSED WHEN THE STOVE IS IN OPERATION.**

### 3. REFUELING THE STOVE

(A) Before attempting to add fuel to the stove, **OPEN** the damper control fully by pulling it all the way out. This allows the chimney to carry away the additional smoke that occurs when the door is open.

(B) **DO NOT OVERLOAD THE STOVE.** Normally, three or four logs will provide heat for several hours. Never operate this stove where portions glow red hot.

### 4. ACHIEVING CATALYST LIGHT OFF FROM A COLD START

The temperature in the stove and the gasses entering the combustor must be raised to between 500 and 700 degrees F. for catalytic activity to be initiated. During the startup of a cold stove, a medium to high firing rate must be maintained for about 20 minutes. This assures that the stove, catalyst, and fuel are all stabilized at the proper operating temperatures. Even though it is possible to have gas temperatures reach 600 degrees F. within two to three minutes after the fire is started, if the fire is allowed to die down immediately, it may go out, or the combustor may stop working. Once the combustor starts working, heat generated by burning smoke will keep it working.

### 5. ACHIEVING CATALYST LIGHT OFF WHEN REFUELING

During the refueling and rekindling of a "charcoal phase" fire, operate the stove at a medium or high firing rate for about 10 minutes to ensure that the catalyst reaches approximately 600 degrees F.

It is important to periodically monitor the operation of the catalytic combustor to ensure that it is functioning properly and to determine when it needs to be replaced. A non-functioning combustor will result in a loss of heating efficiency and an increase in creosote emissions.



## IX. MAINTENANCE

There are areas of the stove and chimney system that need periodic maintenance to ensure safe and efficient operation.

### 1. ASH REMOVAL

When ashes get 3" to 4" deep in your firebox, wait until the stove has cooled, then remove the grate at the bottom of the heater into the ash pan below. Carefully remove the pan. Ashes should be placed on a non-combustible floor or on the ground, away from all combustible materials pending final disposal. The ashes should be retained in the closed container until all cinders have thoroughly cooled.

NOTE: For the most efficient stove operation leave a minimum of 2" ash in the firebox at all times. This will help maintain a hot charcoal bed.

NOTE: DO NOT OVERFIRE THIS HEATER.

Attempts to achieve heat output rates that exceed heater design specifications can result in permanent damage to the heater and to the catalytic combustor.

### 2. CARE OF THE GLASS

The glass supplied with your stove is designed to withstand extremely high temperatures. However, like any glass product, IT CAN BE BROKEN! Take care not to bump it with a log or a poker, and be sure the wood is entirely inside the stove before attempting to close the door.

Periodically opening the drafts and allowing the fire to burn brightly will help reduce the soot buildup on the glass. The glass may be cleaned with a NON-ABRASIVE cleaner such as a spray glass cleaner or oven cleaner.

An effective way of cleaning the glass is to dip a dampened rag in the ashes and scrub the surface clean. The application of a non-stick cooking spray to the inner surface of the glass will help keep it clean.

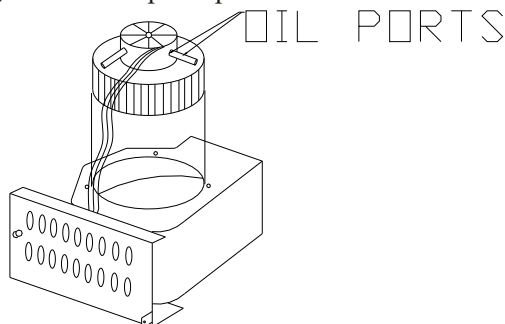

### 3. CHIMNEY CARE

When wood is burned slowly, it produces tar and other organic vapors, which combine with expelled moisture to form creosote. The creosote vapors condense in the relatively cool chimney flue of a slow burning fire. As a result, creosote residue accumulates on the flue lining. The chimney connector and chimney should be inspected at least twice yearly during the heating season to determine if a creosote buildup has occurred.

If creosote has accumulated, it should be removed to reduce the risk of a chimney fire.

NOTE: Insert model stoves should be removed from the fireplace for cleaning. Slide the stove out and place it on a piece of cardboard or drop cloths to protect the floor. The fireplace and throat of the chimney CANNOT be properly cleaned with the stove in place.

### 4. STOVE FINISH

All stoves are finished with a specially formulated high temperature paint. During the first few firings of the stove, a slight odor of paint may be noticed. This is normal during the curing process and the fumes are not hazardous. If they cause irritation, crack a window or door for a few minutes to disperse the fumes.

NOTE: Although non-toxic, the fumes MAY set off a smoke detector located near the stove.

### 5. BLOWER CARE

Remove and clean the blower every four months. Unplug the blower before removing or servicing.

#### TO OIL THE BLOWER:

The blower should be oiled at least two times per season with SAE-20. The oil ports (2) are located on the opposite ends of the center hub on the top side of the blower (see illustration).

### 6. DOOR GASKET REPLACEMENT

Remove all old gasket and clean the gasket channel, if necessary. Put high temperature silicone adhesive in the channel and lay the gasket in so that the ends of the gasket meet in the bottom right corner of the door back. Press down slightly.

### 7. MOTOR MAINTENANCE

Use turbine oil when lubricating motor. Perform this task every six months.

## X. SAFETY

1. If you plan to use an existing chimney with your stove, inspect it thoroughly to be sure it is sound and clean. Advise your insurance company to be sure your policy covers the use of a wood stove.
2. Be sure that firewood, furniture or other combustible materials are stored a safe distance from the stove.
3. Use smoke detectors near the stove as well as other areas of the home.
4. NEVER USE FLAMMABLE LIQUIDS TO START OR "FRESHEN UP" THE FIRE.
5. Periodically inspect the chimney for deterioration and creosote buildup. Clean it regularly to reduce the chances of a chimney fire.
6. Keep a fire extinguisher rated for "Class A" fires near the stove. The dry chemical type is recommended, as liquid types can cause problems if sprayed onto a hot stove. BE SURE EVERY MEMBER OF THE FAMILY KNOWS WHERE THE EXTINGUISHER IS AND HOW TO USE IT!
7. Use of a chimney cap with an approved spark arrestor is recommended.
8. Use caution when loading or working around the stove to prevent burns.
9. Make sure the ash pan drawer is closed when the stove is in operation.

WARNING: THE INSTALLATION OF THIS STOVE MUST COMPLY WITH STATE AND LOCAL REQUIREMENTS AND BE INSPECTED BY THE STATE OR LOCAL INSPECTOR, IF REQUIRED.



APPALACHIAN STOVE & FABRICATORS, INC.  
329 EMMA ROAD  
ASHEVILLE, NC 28806

Phone: (828) 253-0164

Fax: (828) 254-7803

## XI. WARRANTY

The Appalachian Stove is warrantied to be free of defects in materials and workmanship for a period of five years from the date of purchase when used in accordance with the recommendations of the manufacturer, with the following exceptions: electrical, limited to the warranties offered by those respective manufacturers (1 yr.); glass, refractory, firebrick, andirons and decorative trim have no warranty.

Defective parts will be repaired or replaced at the manufacturer's option. Parts which are returned to Appalachian Stove and Fabricators, Inc. within 30 days of purchase and found to be defective on inspection will be replaced without charge for the new part. After 30 days, parts covered by the warranty will be repaired or replaced free with the exception of freight charges which become the responsibility of the purchaser. All replacement parts are shipped F.O.B. factory (freight collect). This warranty does not cover damage caused by alteration, repairs, abuse, tampering, or improper operation of this unit. It does not cover damage from handling or acts of God.

This warranty is in lieu of all other warranties expressed, implied or statutory, and the manufacturer expressly excludes any implied warranty of fitness for a particular purpose or an implied warranty of merchantability, and all other obligations or liabilities of the manufacturer who neither assumes nor authorizes any person to assume for it any other obligations or liability in connection with its products. In addition, the manufacturer shall be held free and harmless from liability from damage to property or injury to persons related to the operation, proper or improper use of the equipment. This warranty applies only to the original purchaser. THERE ARE NO WARRANTIES THAT EXTEND BEYOND THE DESCRIPTION ON THE FACE HEREOF.

All claims made by the purchaser under this warranty should be directed through the dealer from whom the unit was purchased. If the dealer cannot be contacted after reasonable effort, claims may be placed with the Appalachian Stove and Fabricators, Inc.

Stove Model: \_\_\_\_\_

Serial #: \_\_\_\_\_

# STANDARD APPALACHIAN MOTOR REPLACEMENT

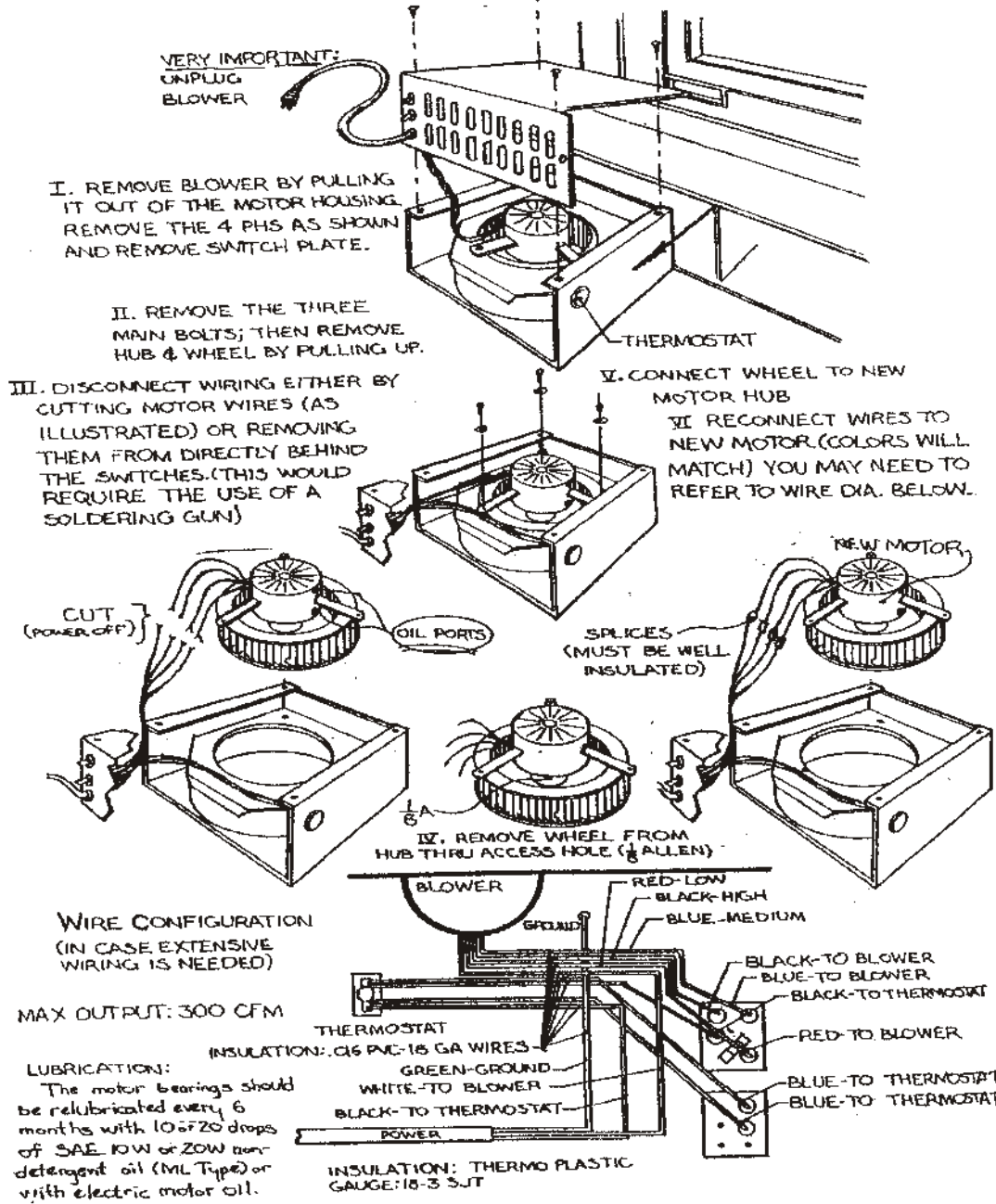

## Ash Dump Handle

Pull ash dump handle out to dump ashes into ash pan. Push handle back in to close.

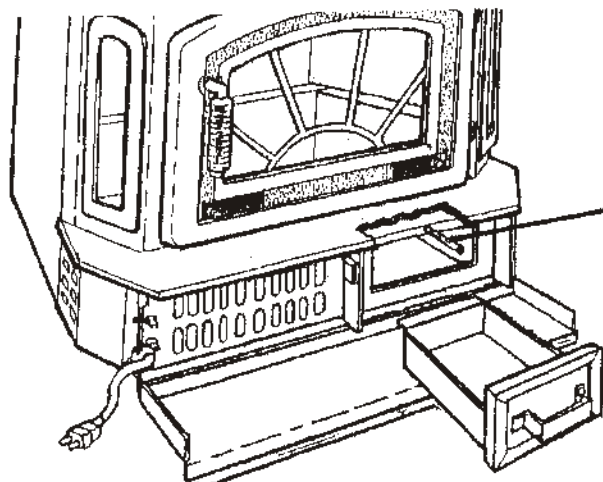



## XII. WARRANTY REGISTRATION

---

NAME: \_\_\_\_\_

ADDRESS: \_\_\_\_\_

\_\_\_\_\_ ZIP \_\_\_\_\_

STOVE MODEL: \_\_\_\_\_

SERIAL NUMBER: \_\_\_\_\_

DATE OF PURCHASE: \_\_\_\_\_

DEALER NAME: \_\_\_\_\_

CITY: \_\_\_\_\_ STATE: \_\_\_\_\_

HOW DID YOU HEAR ABOUT APPALACHIAN STOVE? \_\_\_\_\_

TYPE OF HEAT YOU PRESENTLY HAVE? \_\_\_\_\_

APPROXIMATE SQUARE FEET OF HOME: \_\_\_\_\_

NUMBER OF ROOMS: \_\_\_\_\_

TYPE OF CONSTRUCTION:

\_\_\_ BRICK \_\_\_ LOG \_\_\_ FRAME \_\_\_ MASONRY

HOW DO YOU PLAN ON USING YOUR STOVE?

\_\_\_ PRIMARY HEAT \_\_\_ SUPPLEMENTAL HEAT

ARE THERE OTHER FEATURES OR ACCESSORIES YOU WOULD LIKE TO SEE OFFERED? \_\_\_\_\_